

INNOVATION

FOR PERFECT THERMAL
MANAGEMENT WORLDWIDE





STEGO Catalogue 2020

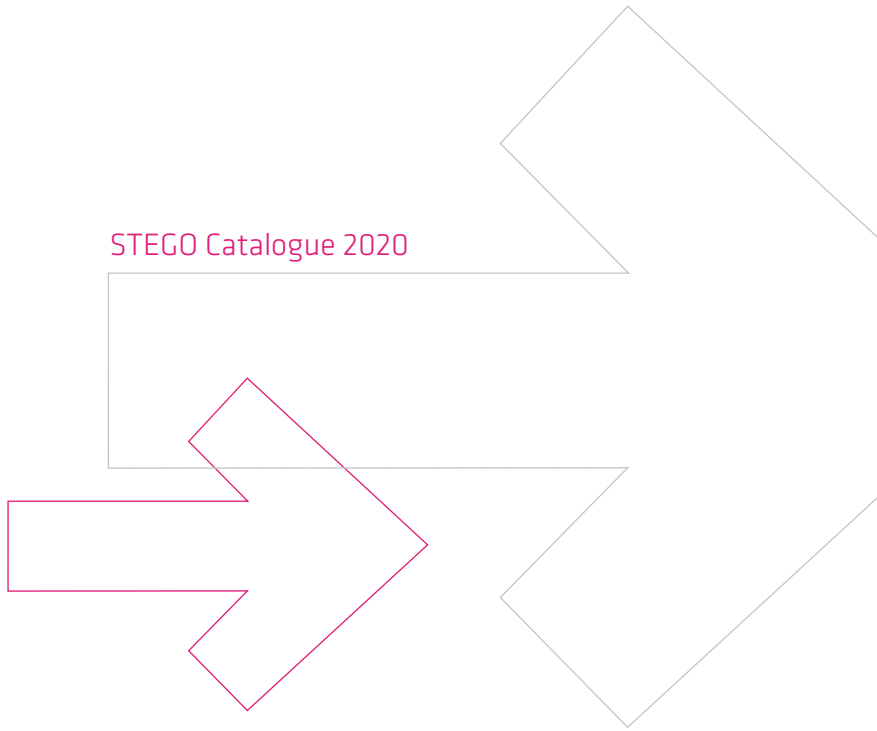



Global presence in Thermal Management



This catalogue contains the full range of STEGO products for protection of electronic components. You will discover why STEGO products are perfectly suitable for the needs of professional users and how easy it is to obtain them worldwide - wherever you are out to succeed.





COMPANY

INNOVATION MADE IN GERMANY

We have been developing and producing innovative products for perfect thermal management for nearly 40 years in Schwäbisch Hall, Germany.

STEGO: SAFETY IS WHAT DRIVES US

STEGO products are used in all places where sensitive electronic components must be protected from humidity and other climatic influences. Heating elements, regulators, fans and STEGO accessories help you to optimise operating conditions and to reach maximum protection for your installations. So that you can be sure of lasting success!

PERFECT THERMAL MANAGEMENT

Since it was founded in 1980, STEGO Elektrotechnik in Schwäbisch Hall, Germany, has been developing, producing and selling an ever-growing range of products for the protection of electric and electronic components. All STEGO products are aimed at reaching optimum climatic conditions in the most varied environments, ensuring that all sensitive components work reliably at all times.

Tried and tested temperature and humidity control systems ensure these optimised climatic conditions. If temperature and/or humidity are too low or too high, the necessary countermeasure is immediately initiated, for example a heater is turned on or a filter fan circulates cool air. A diversity of conditions such as the change from day to night, or particularly warm or cold regions, make climatisation an ever-increasing and challenging task. To meet this challenge, STEGO offers everything that is needed to protect sensitive components from corrosion and malfunction.

WORLDWIDE SERVICE SUPPORTING QUALITY WORLDWIDE

STEGO's thermal management solutions are exported internationally and find use in the most diverse areas of application and climatic conditions. STEGO maintains an on-going exchange with partners and customers from many branches of industry in order to develop innovative products meeting the demands of the market. This close contact enables STEGO to incorporate market requirements from experts directly into our product design. As part of this global cooperation valuable know-how is permanently exchanged, thus strengthening the competence of our designers beyond local market knowledge. The continuous flow of information not only increases the quality of STEGO products, but also the final products our customers bring onto the market. STEGO believes in sustainability, acts in an environmentally-friendly manner and is quality-oriented. The company is DIN EN ISO 9001:2015 and 14001:2015 certified and has introduced the Six Sigma method to improve quality management. Furthermore STEGO meets the requirements of OHSAS 18001 health and safety management. STEGO is now represented at 12 locations and by more than 1500 sales partners worldwide.



PRODUCT SAFETY

The necessity for the safety of electrical devices has always been priority. STEGO continuously invests in product certifications by national and international testing authorities, who test and mark the products according to product safety requirements.

VDE

The VDE Testing and Certification Institute (Verband Deutscher Elektrotechnik) is an authority accredited in Germany but also internationally renowned, which ensures that products comply with applicable standards in terms of safety, quality, health and environmental protection, etc. VDE certified products are subject to factory inspections, manufacturing supervision, as well as product inspections. Depending on classification, our products carry the following VDE marks:



VDE Mark
(electro-technical products)



VDE GS Mark
(technical working equipment)



VDE Registration Number
(factory surveillance for
electro-technical products)



ENEC Mark of VDE
(safety mark for the
European market)

UL

The operation of STEGO products in the US and Canada requires a safety approval by a North American authority due to stricter product liability laws and safety guidelines that deviate from the European IEC standard. The UL mark is the most accepted proof that a product meets applicable safety requirements, not only in the US and Canada but also in many other international markets, as well as in Europe. Underwriter Laboratories (UL) is one of the most recognized product testing and certification organisations today.



CCC

In the People's Republic of China the CCC mark (China Compulsory Certification) is the applicable standard for products that are subject to certification, which can then be imported, sold and used in business activities in China.



EAC

The distribution of electro-technical products within the territory of the Eurasian Economic Union (EAWU) requires EAC labeling. The Eurasian Conformity label indicates that the product complies with applicable safety requirements in the EAWU.



CE

The CE mark is considered „Key to the European market“. It indicates that a product complies with applicable EU laws. It is not a test mark by an authority, but a self-declaration by the manufacturer. With this mark, the manufacturer documents that a marked product complies with all relevant European directives and national laws for product safety and that it has undergone required conformity assessment procedures.



EXPLOSION PROTECTION

Our Ex heaters and thermostats that find use in hazardous areas, such as the chemical, petrochemical and pharmaceutical industry, oil and gas production, mining, etc. are subject to special requirements. The requirements for explosion protection are legally anchored in the ATEX Directive 2014/34/EU of the European Union and the basis for the certification of our Ex products.

Our products are also internationally approved within the scope of a certification process according to IEC standards by an ExCB (Ex Certification Body).



CONTENT

COMPANY STEGO

4

HEATING

13

Small Semiconductor Heater RCE 016 5 W, 9 W	14
Small Semiconductor Heater RC 016 8 W, 10 W, 13 W	15
Small Semiconductor Heater HGK 047 10 W to 30 W	16
Touch-safe Small Heater (Semiconductor) CSK 060 10 W, 20 W	17
Semiconductor Heater HG 140 15 W to 150 W.....	18
Flat Heater CP 061 50 W, 100 W	19
Touch-safe Heater (Semiconductor) CS 060 50 W to 150 W	20
Touch-safe Heater (Semiconductor) CSF 060 50 W to 150 W	21
Space-saving Fan Heater HV 031 / HVL 031 100 W to 400 W	22
Compact Fan Heater HGL 046 250 W, 400 W	23
Compact Semiconductor Fan Heater CS 028 / CSL 028 150 W to 400 W	24
Compact Semiconductor Fan Heater CSF 028 250 W, 400 W	26
Semiconductor Fan Heater CR 027 up to 650 W.....	28
Space-saving Fan Heater HVI 030 500 W to 700 W	30
Space-saving Fan Heater with fan HVI 030 500 W to 700 W	31
Compact High-performance Fan Heater CR 030 950 W.....	32
Compact High-performance Fan Heater CR 130 950 W	33
High-performance Fan Heater (Semiconductor) CS 032 / CSF 032 1,000 W	34
Compact High-performance Fan Heater (Semiconductor) CS 030 1,200 W.....	36
Compact High-performance Fan Heater (Semiconductor) CS 130 1,200 W	37
High-Performance Fan Heater DCR 030 DC 24 V, DC 56 V – 200 W to 800 W	38
High-Performance Fan Heater DCR 130 DC 24 V, DC 56 V – 200 W to 800 W	40

COOLING

43

„Filter Fan Plus“ Principle.....	44
Filter Fan Plus FPI/FPO 018 up to 24 m ³ /h (92 x 92 mm)	46
Filter Fan Plus FPI/FPO 018 up to 97 m ³ /h (124 x 124 mm)	48
Filter Fan Plus FPI/FPO 018 up to 263 m ³ /h (176 x 176 mm).....	50
Filter Fan Plus FPI/FPO 018 up to 536 m ³ /h (223 x 223 mm)	52
Filter Fan Plus FPI/FPO 018 up to 727 m ³ /h (291 x 291 mm).....	54
Filter Fan Plus FPI/FPO 018 – DC Line up to 33 m ³ /h (92 x 92 mm).....	56
Filter Fan Plus FPI/FPO 018 – DC Line up to 125 m ³ /h (124 x 124 mm).....	58
Filter Fan Plus FPI/FPO 018 – DC Line up to 277 m ³ /h (176 x 176 mm).....	60
Hose-Proof Hood FFH 086 IP56	62
Roof Filter Fan RFP 018 300 m ³ /h, 500 m ³ /h.....	63
High-performance 19" Fan Tray LE 019	64
STEGOJET SJ 019.....	65

We offer calculation modules on our websites (www.stego.de, etc.) helping you to determine the required heating or cooling performance for an application. You will also find there latest news, as well as further information about STEGO.

REGULATING/MONITORING 67

Small Compact Thermostat KTO 011 / KTS 011	68
Small Compact Thermostat STO 011 / STS 011	69
Tamper-proof Thermostat (Pre-set) FTO 011 / FTS 011	70
Dual Thermostat ZR 011	71
Tamper-proof Dual Thermostat (Pre-set) FTD 011	72
Mechanical Thermostat FZK 011	73
Electronic Thermostat ETR 011	74
Electronic Thermostat ET 011 DC 24 V	75
Electronic Thermostat ETL 011 DC 12 to 48 V	76
Mechanical Hygrostat MFR 012	77
Electronic Hygrostat EFR 012	78
Electronic Hygrostat EFL 012 DC 12 to 48 V	79
Electronic Hygrotherm ETF 012	80
Electronic Hygrotherm with External Sensor ETF 012	81
Switch Module DCM 010 DC 20 to 56 V	82
Electronic Thermostat DCT 010 DC 20 to 56 V	83
Electronic Hygrostat DCF 010 DC 20 to 56 V	84
Smart Sensor CSS 014 DC 24 V	85

LIGHTING 87

Varioline Lamp LED 021/022	88
Varioline Lamp with Socket LED 121/122	90
Ecoline Lamp LED 025	93
Lamp LED 025	94
Slimline Lamp with On/Off Switch SL 025	96
Slimline Lamp with Movement Sensor SL 025	97
Compact Lamp KL 025	98

ACCESSORIES 99

Electrical Socket SD 035	100
Pressure Compensation Device DA 084 IP55	101
Pressure Compensation Device DA 284 IP66 / IP67	102
Pressure Compensation Device (Stainless Steel) DA 284 IP66	103
Ventilation Cable Gland DAK 284 IP66 / IP67	104
Drainage Device DD 084 IP66 / IP67 / IP69K	105
Door Switch DS 013	106
Appliance Holder STEGOFIX PLUS SFP 095	107

EX PROTECTION 109

Hazardous Area Heater CREx 020 50 W to 250 W (T3)	110
Hazardous Area Heater CREx 020 50 W to 200 W (T4)	111
Hazardous Area Heater CREx 020 50 W, 100 W (T5)	112
Hazardous Area Thermostat REx 011 15 °C, 25 °C (T6)	113

LOCATIONS 114

Indication of measurements in mm. Errors and omissions excepted. Specifications are subject to change without notice. Suitability of the products for their intended use and any associated risks must be determined by the end customer/buyer in their final application. Up-to-date versions of all technical data sheets in pdf-format can be found in the Internet on www.stego.de, www.stego.co.uk or www.stegonorden.se for download.

PROTECTION AGAINST FROST AND CONDENSATION

Optimised temperatures are of utmost importance in switch cabinets: STEGO heaters and fan heaters prevent dangerously low temperatures and ensure equal distribution of warm air.

PROTECTION AGAINST OVERHEATING

To protect installations from excessively high temperatures STEGO filter fans ensure efficient cooling by circulating air.

CONSTANT MONITORING

STEGO's temperature and humidity control systems perfect operating conditions for electric and electronic installations and therefore safeguard their performance.

IDEAL LIGHTING SOLUTIONS

Our lighting solutions ensure that maintenance on electronic installations can be carried out night and day.

COMPLEMENTARY ELECTRONICS PROTECTION

Accessory products from STEGO expand the climatisation portfolio appropriately and offer more specific solutions for individual needs.

EXPLOSION PROTECTION EQUIPMENT

Specific requirements apply to the operation of electrical equipment in hazardous areas. STEGO heaters and thermostats meet international and European standards.

HEATING

COOLING

REGULATING/MONITORING

LIGHTING

ACCESSORIES

EX PROTECTION



HEATING

PROTECTION AGAINST FROST AND CONDENSATION

Optimised temperatures are of utmost importance in switch cabinets: STEGO heaters and fan heaters prevent dangerously low temperatures and ensure equal distribution of warm air.

SMALL SEMICONDUCTOR HEATER

RCE 016 | 5 W, 9 W



- > Wide voltage range
- > Dynamic heating up

- > Energy saving
- > Compact

Small heaters designed to prevent condensation and to ensure a minimum operating temperature in small enclosures. The heaters are designed for permanent operation.



TECHNICAL DATA

Operating voltage	AC/DC 120 – 240 V ¹ (min. 110 V, max. 265 V)
Heating element	PTC resistor, temperature limiting
Heater body	aluminium
Mounting	see Accessories
Fitting position	variable
Dimensions	length 45 mm, Ø 10 mm
Operating/Storage temperature	-45 to +70 °C (-49 to +158 °F)
Operating/Storage humidity	max. 90 % RH (non-condensing)
Protection type/Protection class	IP54 / II (double insulated)
Approvals	VDE, UL File No. E150057 (according to UL 508A, NITW File on request), EAC
Accessories	mounting clips (see illustration), Art. No. 09008.0-01
Note	other voltages on request

¹ Operating with voltages below AC/DC 140 V reduces heating performance by approx. 10 %.

Example of connection

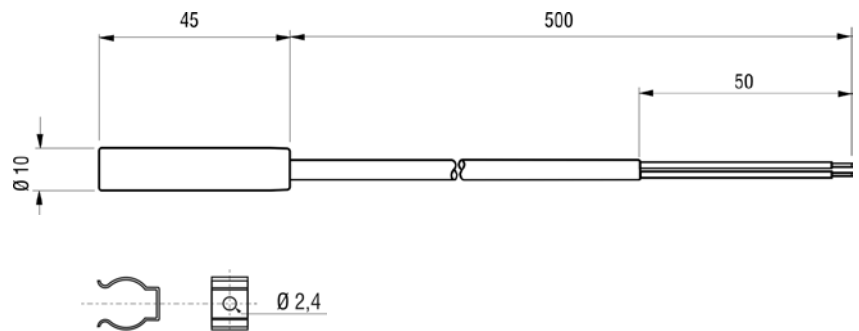
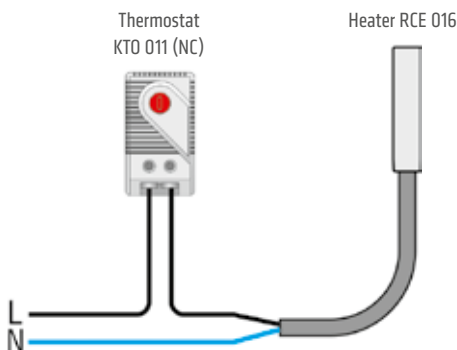

Mounting clips, Art. No. 09008.0-01 (1 packing unit = 2 pieces)

Art. No.	Heating capacity ²	Inrush current max.	Recommended pre-fuse T (time-delay)	Surface temperature (approx.)	Connection	Weight (approx.)
01622.0-00	5 W	2.0 A	2.0 A	+165 °C	2 x AWG 22 cable (silicone)	20 g
01623.0-00	9 W	2.5 A	4.0 A	+175 °C	2 x AWG 22 cable (silicone)	20 g

² at +20 °C (+68 °F) ambient temperature

SMALL SEMICONDUCTOR HEATER

RC 016 | 8 W, 10 W, 13 W



- > Wide voltage range
- > Dynamic heating up

- > Energy saving
- > Compact

These small heaters are designed to prevent condensation and to ensure a minimum operating temperature in small enclosures. The heaters are designed for permanent operation.



TECHNICAL DATA

Operating voltage	AC/DC 120 – 240 V ¹ (min. 110 V, max. 265 V)
Heating element	PTC resistor – temperature limiting
Heater body	aluminium, anodised
Mounting	screw fixing
Fitting position	variable
Operating/Storage temperature	-45 to +70 °C (-49 to +158 °F)
Operating/Storage humidity	max. 90 % RH (non-condensing)
Protection type/Protection class	IP54 / II (double insulated)
Approvals	VDE, UL File No. E150057 (according to UL 508A, NITW File on request), EAC
Note	other voltages on request

¹ Operating with voltages below AC/DC 140 V reduces heating performance by approx. 10 %.

Example of connection

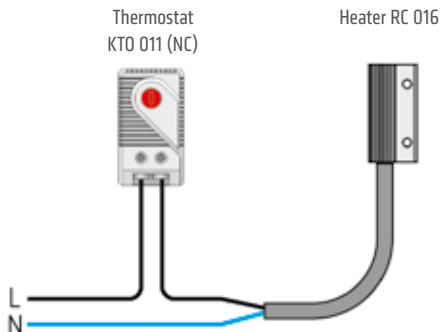

Art. No. 01602.0-00

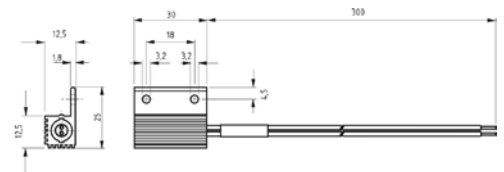

Art. No. 01609.0-00

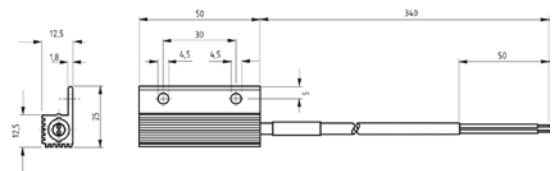

Art. No. 01610.0-00

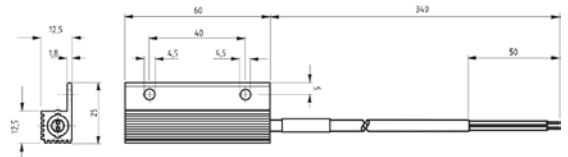

Art. No.	Heating capacity ²	Inrush current max.	Recommended pre-fuse T (time-delay)	Surface temperature (approx.)	Connection	Weight (approx.)
01602.0-00	8 W	2.0 A	2.0 A	+150 °C	2 x AWG 18 stranded wire	20 g
01609.0-00	10 W	2.5 A	4.0 A	+155 °C	2 x AWG 22 cable (silicone)	30 g
01610.0-00	13 W	3.0 A	4.0 A	+170 °C	2 x AWG 22 cable (silicone)	40 g

² at +20 °C (+68 °F) ambient temperature

SMALL SEMICONDUCTOR HEATER

HGK 047 | 10 W to 30 W



- > Dynamic heating up
- > Energy saving

- > Wide voltage range
- > Clip fixing

The heaters are used in enclosures where condensation is to be prevented or the temperature may not fall below a minimum value. In this way corrosion is avoided and an even temperature is ensured. The heaters are designed for permanent operation.

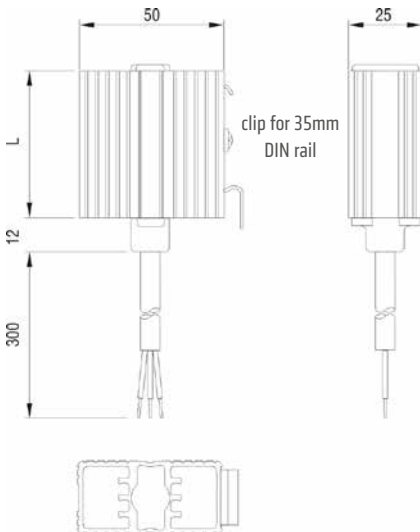

TECHNICAL DATA

Heating element	PTC resistor – temperature limiting
Heater body	extruded aluminium profile, anodised
Mounting	clip for 35mm DIN rail, EN 60715
Fitting position	vertical airflow (air outlet up, connection on bottom)
Operating/Storage temperature	-45 to +70 °C (-49 to +158 °F)
Operating/Storage humidity	max. 90 % RH (non-condensing)
Protection type/Protection class	IP44 / I (earthed)
Accessoires	screw fixing, Art. No. 09024.0-00 (1 packing unit = 2 pieces)
Note	other voltages on request

Example of connection

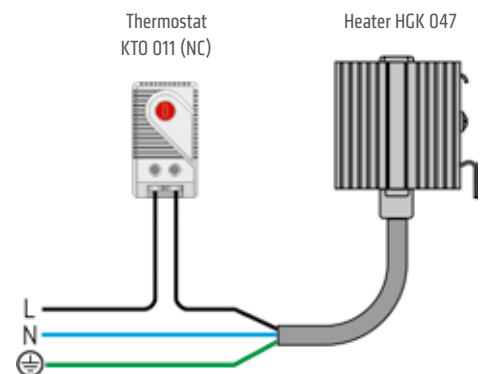

Art. No.	Operating voltage	Heating capacity ¹	Inrush current max.	Recommended pre-fuse T (time-delay)	Length (L)	Weight (approx.)	Connection	Approvals
04700.0-00	AC/DC 120 – 240 V ²	10 W	1.0 A	2.0 A	52 mm	0.1 kg	3 x 0,5 mm ² x 300 mm cable (silicone)	VDE EAC
04701.0-00	AC/DC 120 – 240 V ²	20 W	2.5 A	4.0 A	60 mm	0.2 kg	3 x 0,5 mm ² x 300 mm cable (silicone)	VDE EAC
04702.0-00	AC/DC 120 – 240 V ²	30 W	3.0 A	4.0 A	70 mm	0.2 kg	3 x 0,5 mm ² x 300 mm cable (silicone)	VDE EAC
04700.9-00	AC/DC 110 – 120 V	10 W	1.0 A	2.0 A	52 mm	0.1 kg	3 x AWG 20 x 300 mm cable	UL File No. E150057 EAC
04701.9-00	AC/DC 110 – 120 V	20 W	1.5 A	2.0 A	70 mm	0.2 kg	3 x AWG 20 x 300 mm cable	UL File No. E150057 EAC
04702.9-00	AC/DC 110 – 120 V	30 W	1.5 A	2.0 A	100 mm	0.2 kg	3 x AWG 20 x 300 mm cable	UL File No. E150057 EAC

¹ at +20 °C (+68 °F) ambient temperature, ² (min. 110 V, max 265 V) Operating with voltages below AC/D 140 V reduces heating performance by approx. 10 %.

TOUCH-SAFE SMALL HEATER (SEMICONDUCTOR)

CSK 060 | 10 W, 20 W



- > Low surface temperature
- > Double insulated (plastic housing)
- > Wide voltage range
- > Dynamic heating up
- > Clip fixing

The heaters are used in enclosures where condensation is to be prevented or the temperature may not fall below a minimum value. In this way corrosion is avoided and an even temperature is ensured. The heaters are designed for permanent operation.



TECHNICAL DATA

Operating voltage	AC/DC 120 –240 V ¹ (min. 110 V, max. 265 V)
Heating element	PTC resistor – temperature limiting
Surface temperature	< +85 °C (+185 °F) (according to VDE 0100), except upper protective grille
Connection	2-pole terminal 2.5 mm ² , torque 0.8 Nm max.
Casing	plastic according to UL94 V-0, black
Dimensions	98 x 38 x 75 mm
Mounting	clip for 35mm DIN rail, EN 60715
Fitting position	vertical airflow (air outlet up, connection on bottom)
Operating/Storage temperature	-45 °C to +70 °C (-49 °F to +158 °F)
Operating/Storage humidity	max. 90 % RH (non-condensing)
Protection type/Protection class	IP20 / II (double insulated)
Approvals	VDE, UL File No. E150057, EAC
Note	other voltages on request

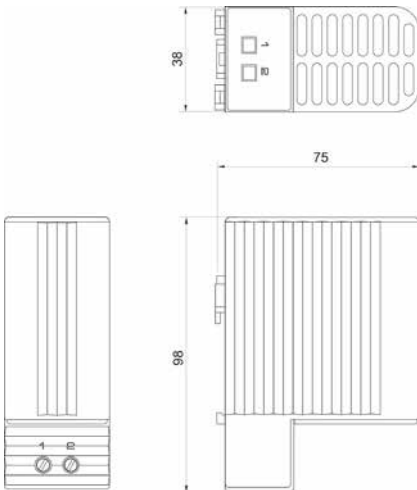

¹ Operating with voltages below AC/DC 140 V reduces heating performance by approx 10 %.

Example of connection

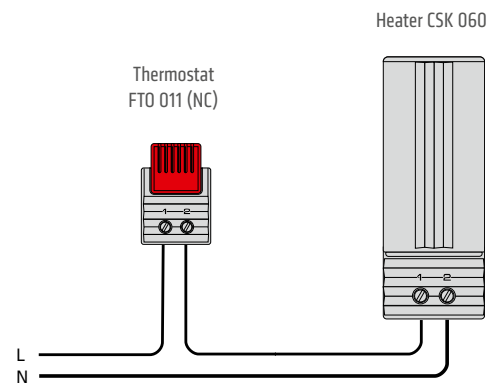

Art. No.	Heating capacity ²	Inrush current max.	Recommended pre-fuse T (time-delay)	Weight (approx.)
06040.0-00	10 W	1.0 A	2.0 A	0.2 kg
06030.0-00	20 W	2.5 A	4.0 A	0.3 kg

² at +20 °C (+68 °F) ambient temperature

SEMICONDUCTOR HEATER

HG 140 | 15 W to 150 W



- > Pressure clamp connectors
- > Dynamic heating up
- > Wide voltage range
- > Energy saving
- > Clip fixing
- > Quick installation

These heaters are used in enclosures where damage from condensation must be prevented, or where the temperature may not fall below a minimum value. The aluminium profile heater body design has a chimney effect and distributes the heat evenly. The heaters are designed for permanent operation. Pressure clamp connectors save time and simplify installation.

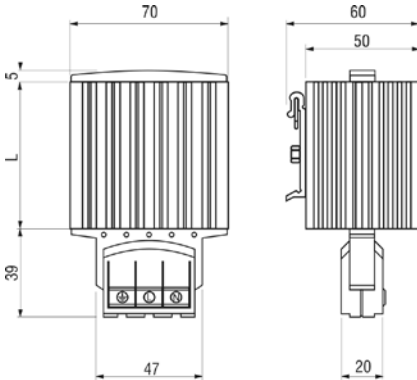

TECHNICAL DATA

Operating voltage	AC/DC 120 – 240 V ¹ (min. 110 V, max. 265 V)
Heating element	PTC resistor – temperature limiting
Heater body	extruded aluminium profile, anodised
Connection	3 pressure clamps for stranded wire 0.5 – 1.5 mm ² (with wire end ferrule) and rigid wire 0.5 – 2.5 mm ²
Connection casing	plastic according to UL94 V-0, black
Mounting	clip for 35 mm DIN rail, EN 60715
Fitting position	vertical airflow (air outlet up, connection on bottom)
Operating/Storage temperature	-45 to +70 °C (-49 to +158 °F)
Operating/Storage humidity	max. 90 % RH (non-condensing)
Protection type/Protection class	IP20 / I (earthed)
Approvals	VDE, UL File No. E150057, EAC
Accessoires	screw fixing, Art. No. 09024.0-00 (1 packing unit = 2 pieces)
Note	other voltages on request

¹ Operating with voltages below AC/DC 140 V reduces heating performance by approx. 10 %.

Art. No.	Heating capacity ²	Inrush current max.	Recommended pre-fuse T (time-delay)	Length (L)	Weight (approx.)
14000.0-00	15 W	1.5 A	2.0 A	65 mm	0.3 kg
14001.0-00	30 W	3.0 A	4.0 A	65 mm	0.3 kg
14003.0-00	45 W	3.5 A	4.0 A	65 mm	0.3 kg
14005.0-00	60 W	2.5 A	4.0 A	140 mm	0.4 kg
14006.0-00	75 W	4.0 A	6.3 A	140 mm	0.5 kg
14007.0-00	100 W	4.5 A	8.0 A	140 mm	0.5 kg
14008.0-00	150 W	9.0 A	10.0 A	220 mm	0.7 kg

² at +20 °C (+68 °F) ambient temperature

FLAT HEATER

CP 061 | 50 W, 100 W



- > Contact/Convection heater
- > Ultra flat design
- > Compact
- > Easy, firm installation
- > Screw fixing
- > Linear expansion compensation
- > Integrated temperature cut-out
- > Ready-to-use with strain relief

The Flat Heater CP 061 is used to provide an evenly distributed temperature within enclosures and cabinets with electric/electronic components. Its ultra-thin design makes it particularly suitable for high-density applications for which standard enclosure heaters are often too big in size. Depending on the application, the Flat Heater can be used as a convection heater or as a contact heater. When used as a contact heater it offers thermoconductive contact to a component or a cabinet wall in need to be heated. Additionally, a mounting system especially designed for the CP 061 allows for the compensation of an expansion of the heater body as a result of the heating-up when in operation. Operated as a convection heater, the slim heater CP 061 warms up the ambient air within a cabinet. The CP 061 is designed for continuous operation.



TECHNICAL DATA

Heating element	resistance heater
Temperature safety cut-out	to protect against overheating, automatic reset
Heater body	aluminium profile
Surface temperature	max. +150 °C at +25 °C (+77 °F)
Connection	silicone cable (halogen-free) 3 x 0.75 mm ² , length 1 m
Connection casing	plastic according to UL94 V-0, black
Mounting	screw fixing (M6)
Fitting position	horizontal, variable connection or vertical, connection on bottom
Dimensions	L x 100 x 8 mm
Operating/Storage temperature	-40 to +60 °C (-40 to +140 °F) / -40 to +85 °C (-40 to +185 °F)
Operating/Storage humidity	max. 90 % RH (non-condensing)
Protection type/Protection class	IP30 / I (earthed)
Note	other voltages (AC 120 V) on request

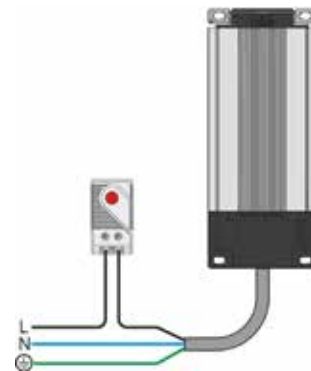
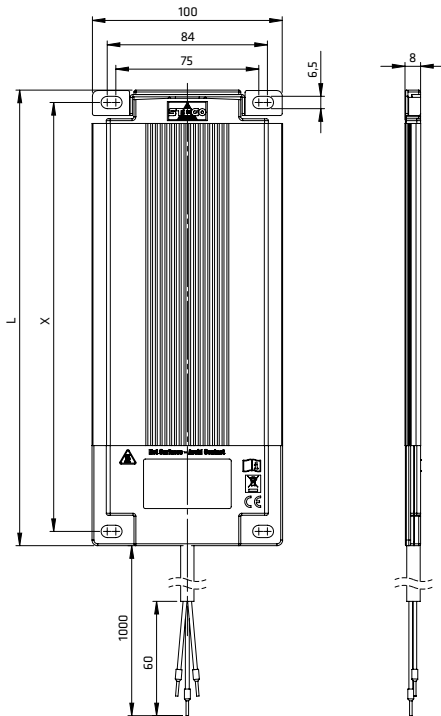

Example of connection

Art. No.	Operating voltage	Heating capacity	Length (L)	Hole spacing (X)	Weight (approx.)	Approvals	
06100.0-00	AC 230 V, 50/60 Hz	50 W	239 mm	225 mm	0.4 kg	VDE	EAC
06101.0-00	AC 230 V, 50/60 Hz	100 W	414 mm	400 mm	0.7 kg	VDE	EAC

TOUCH-SAFE HEATER (SEMICONDUCTOR)

CS 060 | 50 W to 150 W



- > Low surface temperature
- > Quick mounting due to clip fixing
- > Double insulated (plastic)
- > Wide voltage range
- > Small size

Touch-safe heater for the use in enclosures with electrical/electronic components. The design of the heater supports the natural convection which results in a high air-current of warm air. The surface temperatures on the accessible side surfaces of the housing are kept down as a result of the heater design. Our complete range of thermostats and hygrostats can directly be connected to the heater CS 060. This heater is also available in a version with plug-in thermostat requiring no additional wiring (CSF 060). The heaters are designed for permanent operation.



TECHNICAL DATA

Operating voltage	AC/DC 120 – 240 V ¹ (min. 110 V, max. 265 V)
Heating element	PTC resistor – temperature limiting
Surface temperature	< +80 °C (+176 °F), except upper protective grille
Connection	4-pole terminal 2.5 mm ² , torque 0.8 Nm max.
Casing	plastic according to UL94 V-0, black
Mounting	clip for 35 mm DIN rail, EN 60715
Fitting position	vertical airflow (air outlet up, connection on bottom)
Operating/Storage temperature	-45 to +70 °C (-49 to +158 °F)
Operating/Storage humidity	max. 90 % RH (non-condensing)
Protection type/Protection class	IP20 / II (double insulated)
Approvals	VDE, UL File No. E150057, EAC
Note	other voltages on request

¹ Operating with voltages below AC/DC 140 V reduces heating performance by approx. 10 %.

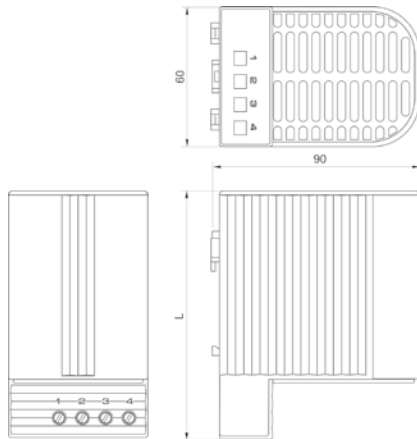

Examples of connection

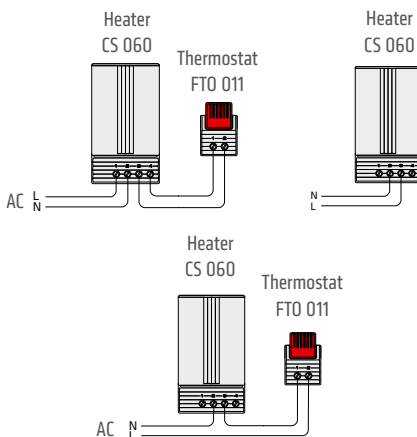

Heating capacity / Ambient temperature diagram CS 060

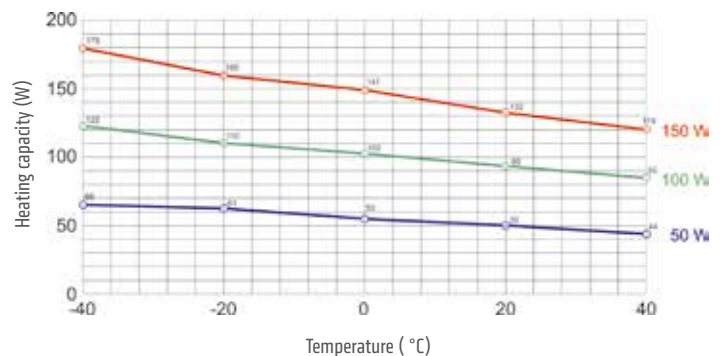

Art. No.	Heating capacity ²	Inrush current (max.)	Recommended pre-fuse T (time-delay)	Air outlet temperature ³	Dimensions	Weight (approx.)
06000.0-00	50 W	2.5 A	4.0 A	+86 °C (+186.8 °F)	110 x 60 x 90 mm	0.3 kg
06010.0-00	100 W	4.5 A	8.0 A	+120 °C (+248 °F)	110 x 60 x 90 mm	0.3 kg
06020.0-00	150 W	8.0 A	10.0 A	+145 °C (+293 °F)	150 x 60 x 90 mm	0.5 kg

² ambient temperature – see Heating capacity / ambient temperature diagram; ³ measured 50 mm above protective grille

TOUCH-SAFE HEATER (SEMICONDUCTOR)

CSF 060 | 50 W to 150 W



- > Low surface temperature
- > Integrated thermostat
- > Quick mounting due to clip fixing
- > Double insulated (plastic)
- > Wide voltage range
- > Small size

Touch-safe heater for the use in enclosures with electrical/electronic components. The design of the heater supports the natural convection which results in a high air-current of warm air. The surface temperatures on the accessible side surfaces of the housing are kept down as a result of the heater design. This model with plug-in thermostat does not require additional wiring. The heaters are designed for permanent operation. This heater is also available in a version without thermostat (CS 060).



TECHNICAL DATA

Operating voltage	AC 120 – 240 V ¹ (min. 110 V, max. 265 V)
Heating element	PTC resistor – temperature limiting
Surface temperature	< +80 °C (+176 °F), except upper protective grille
Connection	2-pole terminal 2.5 mm ² , torque 0.8 Nm max.
Casing	plastic according to UL94 V-0, black
Mounting	clip for 35 mm DIN rail, EN 60715
Fitting position	vertical airflow (air outlet up, connection on bottom)
Operating/Storage temperature	-40 to +70 °C (-40 to +158 °F) / -45 to +70 °C (-49 to +158 °F)
Operating/Storage humidity	max. 90 % RH (non-condensing)
Protection type/Protection class	IP20 / II (double insulated)
Approvals	VDE, UL File No. E150057, EAC

¹ Operating with voltages below AC 140 V reduces heating performance by approx. 10 %.

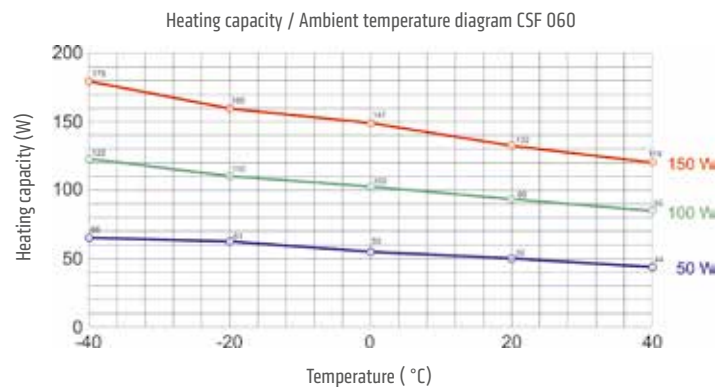
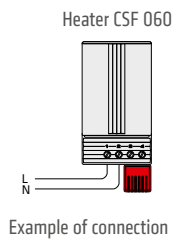
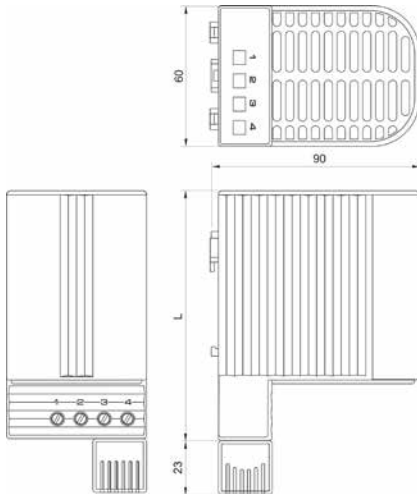

Art. No.	Heating capacity ²	Inrush current (max.)	Recommended pre-fuse T (time-delay)	Air outlet temperature ³	Switch-off temperature ⁴	Switch-on temperature ⁴	Dimensions	Weight (approx.)
06001.0-00	50 W	2.5 A	4.0 A	+86 °C (+186.8 °F)	+15 °C (+59 °F)	+5 °C (+41 °F)	110 x 60 x 90 mm	0.3 kg
06002.0-00	50 W	2.5 A	4.0 A	+86 °C (+186.8 °F)	+25 °C (+77 °F)	+15 °C (+59 °F)	110 x 60 x 90 mm	0.3 kg
06011.0-00	100 W	4.5 A	8.0 A	+120 °C (+248 °F)	+15 °C (+59 °F)	+5 °C (+41 °F)	110 x 60 x 90 mm	0.3 kg
06012.0-00	100 W	4.5 A	8.0 A	+120 °C (+248 °F)	+25 °C (+77 °F)	+15 °C (+59 °F)	110 x 60 x 90 mm	0.3 kg
06021.0-00	150 W	8.0 A	10.0 A	+145 °C (+293 °F)	+15 °C (+59 °F)	+5 °C (+41 °F)	150 x 60 x 90 mm	0.5 kg
06022.0-00	150 W	8.0 A	10.0 A	+145 °C (+293 °F)	+25 °C (+77 °F)	+15 °C (+59 °F)	150 x 60 x 90 mm	0.5 kg

² ambient temperature – see Heating capacity / ambient temperature diagram; ³ measured 50 mm above protective grille; ⁴ tolerance of ±5 K
Note: Other switch-off and switch-on temperatures on request.

SPACE-SAVING FAN HEATER

HV 031 / HVL 031 | 100 W to 400 W



- > Compact
- > Temperature safety cut-out
- > Flat design
- > Clip fixing
- > High air through-flow

Compact high-performance fan heater prevents formation of condensation and frost and provides an evenly distributed interior air temperature in enclosures with electric/electronic components. This fan heater may only be operated together with a fan but is also available without fan for self-assembly (HV 031) and with pre-configured fan (HVL 031).



TECHNICAL DATA

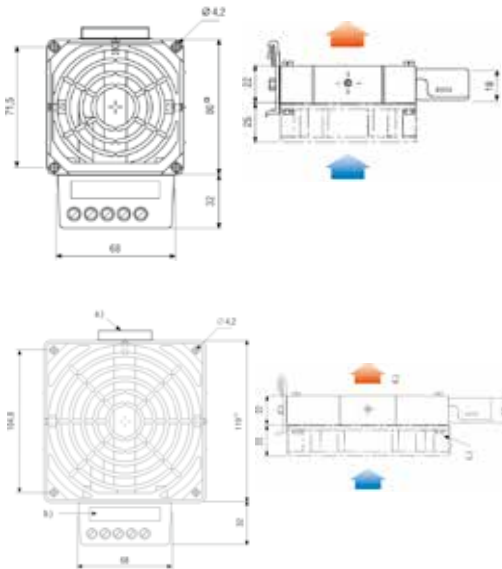

a.) Clip
b.) Type plate
c.) Axial fan
d.) Air direction

HV 031	Heater without fan (fan mounting kit included)
HVL 031	Heater with fan
Heating element	high performance cartridge
Temperature safety cut-out	to protect against overheating in case of fan failure, automatic reset
Heater body	die-cast aluminium (glass bead blasted)
Connection	3-pole screw connector 2.5 mm ² , clamping torque 0.8 Nm max.
Connection casing	plastic according to UL94 V-0, black
Mounting	clip for 35 mm DIN rail, EN 60715
Fitting position	vertical airflow (air outlet up)
Operating/Storage temperature	-45 to +70 °C (-49 to +158 °F)
Operating/Storage humidity	max. 90 % RH (non-condensing)
Protection type/Protection class	IP20 / I (earthed)
Approvals	UL File No. E234324, EAC VDE only: 230 V
HVL 031 only:	
Axial fan, ball bearing	airflow see table service life 50,000 h at +25 °C (+77 °F)
Connection (axial fan)	2-pole screw connector 2.5 mm ² (L2/N2)



Important note: Heater may only be operated together with fan.
Danger of overheating!

Art. No. HV 031 AC 230 V, 50/60 Hz	Art. No. HV 031 AC 120 V, 50/60 Hz	Heating capacity	Recommended pre-fuse T (time-delay)		Dimensions	Weight (approx.)
			AC 230 V	AC 120 V		
03100.0-00	03100.9-00	100 W	1.0 A	2.0 A	80 x 112 x 22 mm	0.4 kg
03101.0-00	03101.9-00	150 W	1.25 A	2.5 A	80 x 112 x 22 mm	0.4 kg
03110.0-00	03110.9-00	200 W	2.0 A	3.0 A	119 x 151 x 22 mm	0.5 kg
03111.0-00	03111.9-00	300 W	2.0 A	4.0 A	119 x 151 x 22 mm	0.5 kg
03112.0-00	03112.9-00	400 W	4.0 A	6.3 A	119 x 151 x 22 mm	0.5 kg

Art. No. HVL 031 AC 230 V, 50/60 Hz	Art. No. HVL 031 AC 120 V, 50/60 Hz	Heating capacity	Recommended pre-fuse T (time-delay)		Airflow min., free flow	Dimensions	Weight (approx.)
			AC 230 V	AC 120 V			
03102.0-00	03102.9-00	100 W	1.0 A	2.0 A	35 m ³ /h	80 x 112 x 47 mm	0.6 kg
03103.0-00	03103.9-00	150 W	1.25 A	2.5 A	35 m ³ /h	80 x 112 x 47 mm	0.6 kg
03113.0-00	03113.9-00	200 W	2.0 A	3.0 A	108 m ³ /h	119 x 151 x 47 mm	0.9 kg
03114.0-00	03114.9-00	300 W	2.0 A	4.0 A	108 m ³ /h	119 x 151 x 47 mm	0.9 kg
03115.0-00	03115.9-00	400 W	4.0 A	6.3 A	108 m ³ /h	119 x 151 x 47 mm	0.9 kg

COMPACT FAN HEATER

HGL 046 | 250 W, 400 W



- > Compact Design
- > Long service life
- > Clip fixing
- > Temperature safety cut-out

Compact fan heater prevents formation of condensation and frost. The integrated high-performance axial fan provides an evenly distributed interior air temperature in enclosures with electric/electronic components.



TECHNICAL DATA

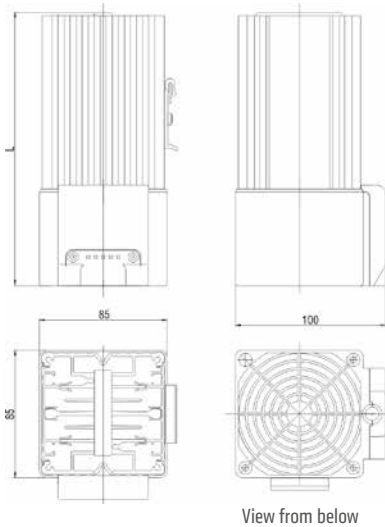

Heating element	resistance heater
Temperature safety cut-out	to protect against overheating in case of fan failure, automatic reset
Heater body	anodised extruded aluminium profile
Surface temperature	max. +75 °C (400 W)
Axial fan, ball bearing	Airflow, free flow 45 m ³ /h (50 Hz) or 54 m ³ /h (60 Hz) service life 50,000 h at +25 °C (+77 °F)
Connection	internal connection terminal 1.5 mm ² with strain relief, clamping torque 0.8 Nm max.
Connection casing	plastic according to UL94 V-0, black
Mounting	clip for 35 mm DIN rail, EN 60715
Fitting position	vertical airflow (air outlet up)
Operating/Storage temperature	-45 to +70 °C (-49 to +158 °F)
Operating/Storage humidity	max. 90 % RH (non-condensing)
Protection type/Protection class	IP20 / I (earthed)
Note	other voltages on request

Example of connection

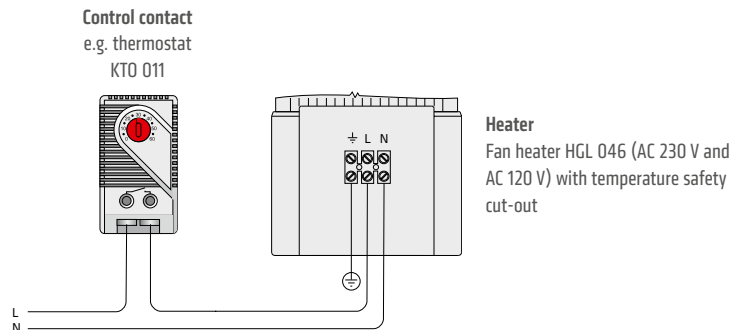

Art. No.	Operating voltage	Heating capacity	Recommended pre-fuse T (time-delay)	Length (L)	Weight (approx.)	Approvals		
04640.0-00	AC 230 V, 50/60 Hz	250 W	2.0 A	182 mm	1.1 kg	VDE	UL File No. E150057 ¹	EAC
04641.0-00	AC 230 V, 50/60 Hz	400 W	4.0 A	222 mm	1.4 kg	VDE	UL File No. E150057 ¹	EAC
04640.9-00	AC 120 V, 50/60 Hz	250 W	4.0 A	182 mm	1.1 kg	VDE	UL File No. E150057 ¹	EAC
04641.9-00	AC 120 V, 50/60 Hz	400 W	6.3 A	222 mm	1.4 kg	VDE	UL File No. E150057 ¹	EAC

¹ according to UL 508A, NITW File on request

COMPACT SEMICONDUCTOR FAN HEATER

CS 028 / CSL 028 | 150 W to 400 W



Fan Heaters CSL 028/CS 028 with clip fixing



Fan Heaters CSL 028/CS 028 with screw fixing

- > Small, compact design
- > Dynamic heating up
- > Quiet in operation
- > Clip or screw fixing

These fan heaters prevent formation of condensation and provide an evenly distributed interior air temperature in enclosures with electric/electronic components. The heaters are connected using the internal terminal connectors. The small size of the CS / CSL 028 heaters make them ideal for use in enclosures where space is at a premium.



TECHNICAL DATA

Heating element	PTC resistor – temperature limiting
Axial fan, ball bearing	air flow, free flow CS 028: 13.8 m ³ /h CSL 028: 45 m ³ /h (AC 230 V), 54 m ³ /h (AC 120 V) service life 40,000 h at +40 °C (+104 °F)
Connection	2-pole clamp max. 2.5 mm ² (CSL 028 with strain relief), clamping screw torque 0.8 Nm max.
Casing	plastic according to UL94 V-0, black
Mounting	clip for 35 mm DIN rail, EN 60715 or screw fixing (Ø 5.3 mm)
Fitting position	vertical airflow (air outlet up)
Dimensions	see drawings
Operating/Storage temperature	-45 to +70 °C (-49 to +158 °F)
Operating/Storage humidity	max. 90 % RH (non-condensing)
Protection type/Protection class	IP20 / II (double insulated)
Note	other voltages on request

Heating capacity / Ambient temperature diagram CS 028 / CSL 028

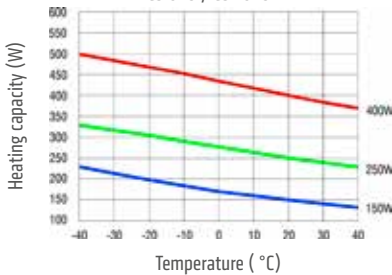

Example of connection

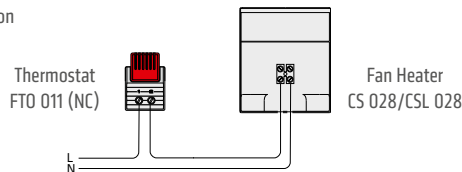

FAN HEATER CS 028

Art. No. clip fixing	Art. No. screw fixing	Operating voltage	Heating capacity ¹	Inrush current max.	Recommended pre-fuse T (time-delay)	Weight (approx.)	Approvals		
02800.0-00	02800.0-01	AC 230 V, 50/60 Hz	150 W	12.0 A	10.0 A	0.3 kg	VDE	UL	EAC
02800.9-00	02800.9-01	AC 120 V, 50/60 Hz	150 W	6.0 A	10.0 A	0.3 kg	-	UL File No. E234324	EAC

FAN HEATER CSL 028

Art. No. clip fixing	Art. No. screw fixing	Operating voltage	Heating capacity ¹	Inrush current max.	Recommended pre-fuse T (time-delay)	Weight (approx.)	Approvals		
02811.0-00	02811.0-01	AC 230 V, 50/60 Hz	250 W	9.0 A	10.0 A	0.5 kg	VDE	UL	EAC
02810.0-00	02810.0-01	AC 230 V, 50/60 Hz	400 W	15.0 A	16.0 A	0.5 kg	VDE	UL	EAC
02811.9-00	02811.9-01	AC 120 V, 50/60 Hz	250 W	6.0 A	10.0 A	0.5 kg	-	UL File No. E234324	EAC
02810.9-00	02810.9-01	AC 120 V, 50/60 Hz	400 W	9.0 A	10.0 A	0.5 kg	-	UL File No. E234324	EAC

¹ at +20 °C (+68 °F) ambient temperature

TECHNICAL DRAWINGS

CLIP FIXING

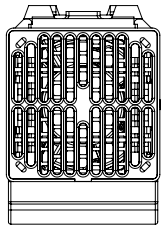
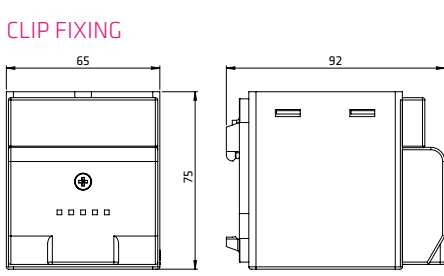

Fan Heater CS 028

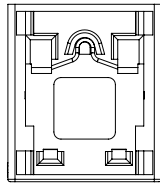

View: back side

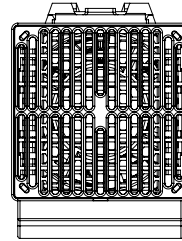
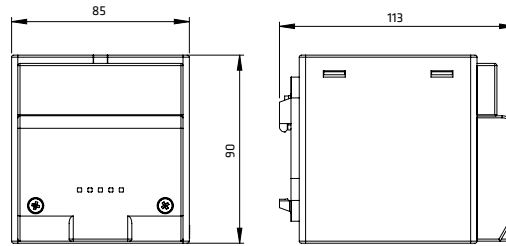

Fan Heater CSL 028

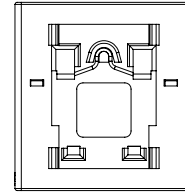

View: back side

SCREW FIXING

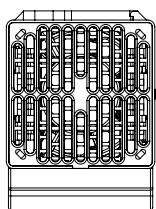
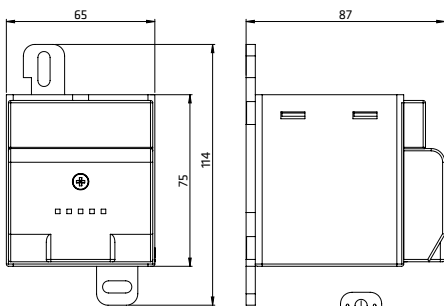

Fan Heater CS 028

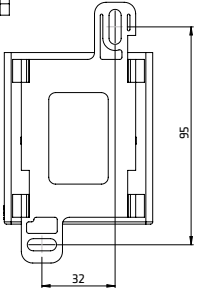

View: back side

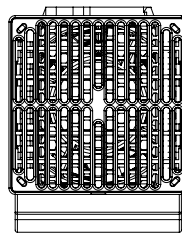
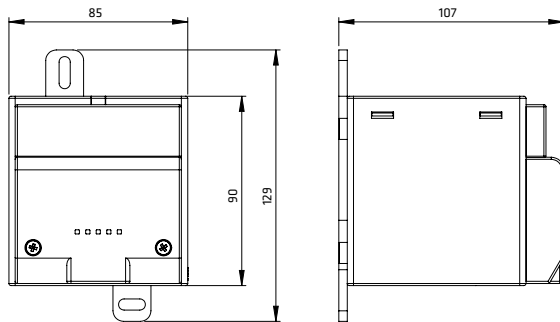

Fan Heater CSL 028

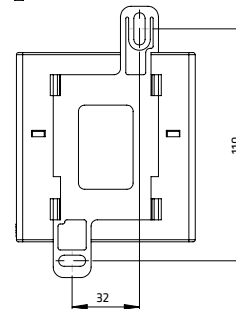

View: back side

ACCESSORY PART FOR FAN HEATER CSL 028

Air duct for improved heat distribution

The air duct is an accessory part for use with the fan heater CSL 028. It can easily be clipped onto the protective grille of the fan heater without use of any tools, and diverts the exiting warm air by 45°. This results in an overall improved heat distribution within an enclosure or cabinet. The temperature above the protective grille is reduced by up to 20 °C (measured 100 mm above protective grille) and may make the use of a heat conduction plate obsolete.



Air duct Art. No. 252017

Fan heater with air duct

Art. No.	Dimensions ²	Plastic	1 Packing unit	Weight (approx.)
252017	85 x 85 x 12 mm	according to UL94 V-0, black	1 piece	35 g

² Dimensions when mounted on fan heater.

COMPACT SEMICONDUCTOR FAN HEATER

CSF 028 | 250 W, 400 W



CSF 028 with clip fixing



CSF 028 with screw flange fixing

- > Small, compact design
- > Integrated pre-set thermostat
- > Dynamic heating up
- > Quick connection
- > Clip or screw flange fixing

The compact fan heater prevents formation of condensation and provides an evenly distributed interior air temperature in enclosures with electric/electronic components. The touch-safe plastic housing and the small dimensions makes it ideal for use in enclosures with high packing density. The CSF 028 is equipped with a preset thermostat. It is connected via external clamps. The fan heater is available with two different mounting systems – either mounting by screw flange or by clip. The robust screw flange fixing is particularly suitable for applications with high vibration.



TECHNICAL DATA

Heating element	PTC resistor – temperature limiting
Temperature safety cut-out	to protect against overheating in case of fan failure, automatic reset
Axial fan, ball bearing	air flow, free flow CSF 028: 45 m ³ /h (AC 230 V), 54 m ³ /h (AC 120 V) service life 40,000 h at +40 °C (+104 °F)
Connection	2-pole dual pressure clamp for rigid wire 2.5 mm ² , stranded wire (with wire end ferrule) 1.5 mm ²
Casing	plastic according to UL94 V-0, black
Mounting	clip for 35 mm DIN rail, EN 60715 or screw fixing (Ø 5.5 mm), clamping torque 2 Nm max., washers have to be used
Fitting position	vertical airflow (air outlet up)
Dimensions	models with clip fixing: 105 x 85 x 118 mm, models with screw flange fixing: 105 x 115 x 108 mm
Weight	0.5 kg
Operating/Storage temperature	-40 to +70 °C (-40 to +158 °F)/-45 to +70 °C (-49 to +158 °F)
Operating/Storage humidity	max. 90 % RH (non-condensing)
Protection type/Protection class	IP20 / II (double insulated)

Art. No. clip fixing	Art. No. screw flange fixing	Operating voltage	Heating capacity ¹	Inrush current max.	Recommended pre-fuse I (time-delay)	Switch-off temperature ²	Switch-on temperature ²	Approvals		
02821.0-06	02821.0-08	AC 230 V, 50/60 Hz	250 W	9,0 A	10,0 A	+15 °C (+59 °F)	+5 °C (+41 °F)	VDE	UL	EAC
02821.0-09	02821.0-11	AC 230 V, 50/60 Hz	250 W	9,0 A	10,0 A	+25 °C (+77 °F)	+15 °C (+59 °F)	VDE	UL	EAC
02820.0-06	02820.0-08	AC 230 V, 50/60 Hz	400 W	15,0 A	16,0 A	+15 °C (+59 °F)	+5 °C (+41 °F)	VDE	UL	EAC
02820.0-09	02820.0-11	AC 230 V, 50/60 Hz	400 W	15,0 A	16,0 A	+25 °C (+77 °F)	+15 °C (+59 °F)	VDE	UL	EAC
02821.9-06	02821.9-08	AC 120 V, 50/60 Hz	250 W	6,0 A	10,0 A	+15 °C (+59 °F)	+5 °C (+41 °F)	-	UL File No. E234324	EAC
02821.9-09	02821.9-11	AC 120 V, 50/60 Hz	250 W	6,0 A	10,0 A	+25 °C (+77 °F)	+15 °C (+59 °F)	-	UL File No. E234324	EAC
02820.9-06	02820.9-08	AC 120 V, 50/60 Hz	400 W	9,0 A	10,0 A	+15 °C (+59 °F)	+5 °C (+41 °F)	-	UL File No. E234324	EAC
02820.9-09	02820.9-11	AC 120 V, 50/60 Hz	400 W	9,0 A	10,0 A	+25 °C (+77 °F)	+15 °C (+59 °F)	-	UL File No. E234324	EAC

¹ at +20 °C (+68 °F) ambient temperature; ² tolerance of ±5 K
Note: Other switch-off and switch-on temperatures on request.

TECHNICAL DRAWINGS

CLIP FIXING

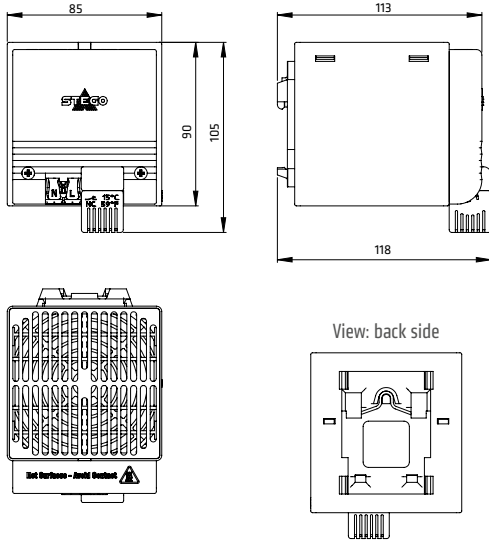

SCREW FLANGE FIXING

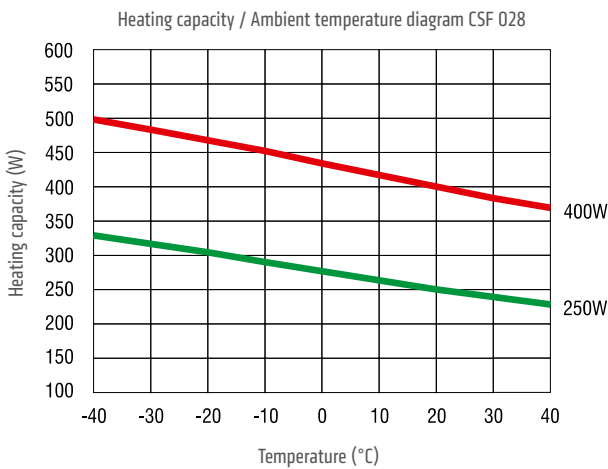
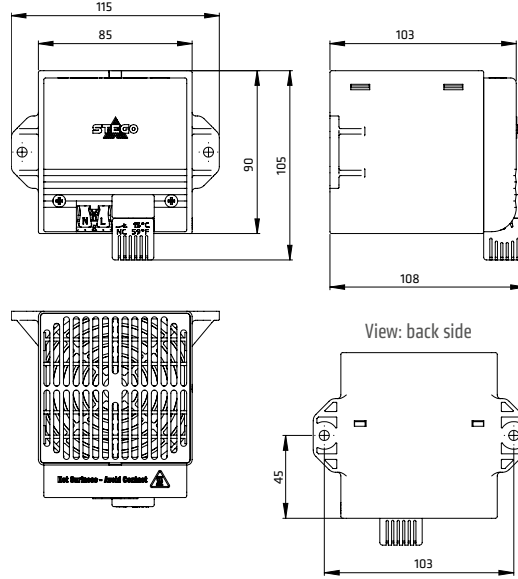

Example of connection Fan heater CSF 028

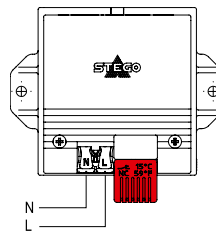

ACCESSORIES

Air duct for improved heat distribution

The air duct is an accessory part for use with the fan heater CSF 028. It can easily be clipped onto the protective grille of the fan heater without use of any tools, and diverts the exiting warm air by 45°. This results in an overall improved heat distribution within an enclosure or cabinet. The temperature above the protective grille is reduced by up to 20 °C (measured 100 mm above protective grille) and may make the use of a heat conduction plate obsolete.



Art. No.	Dimensions ²	Plastic	1 Packing unit	Weight (approx.)
252017	85 x 85 x 12 mm	according to UL94 V-0, black	1 piece	35 g

² Dimensions when mounted on fan heater.

SEMICONDUCTOR FAN HEATER

CR 027 | up to 650 W



- > Compact heater
 - > Integrated thermostat
 - > Clip fixing
- > Optical indicator
 - > Temperature safety cut-out

Semiconductor fan heater prevents formation of condensation and frost and provides an evenly distributed interior air temperature in enclosures with electric/electronic components. The integrated thermostat is used to set the desired temperature.



TECHNICAL DATA

Heating element	PTC resistor – temperature limiting
Temperature safety cut-out	to protect against overheating in case of fan failure, automatic reset
Axial fan, ball bearing	airflow see table service life 50,000 h at +25 °C (+77 °F)
Connection	2-pole clamp 2.5 mm ² , clamping torque 0.8 Nm max
Casing	plastic according to UL94 V-0, light grey
Optical indicator	thermostat control lamp
Mounting	clip for 35 mm DIN rail, EN 60715
Fitting position	vertical airflow (air outlet up)
Dimensions	100 x 128 x 165 mm
Operating/Storage temperature	-45 to +70 °C (-49 to +158 °F)
Operating/Storage humidity	max. 90 % RH (non-condensing)
Protection type/Protection class	IP20 / II (double insulated)
Approvals	VDE, UL File No. E204590, EAC

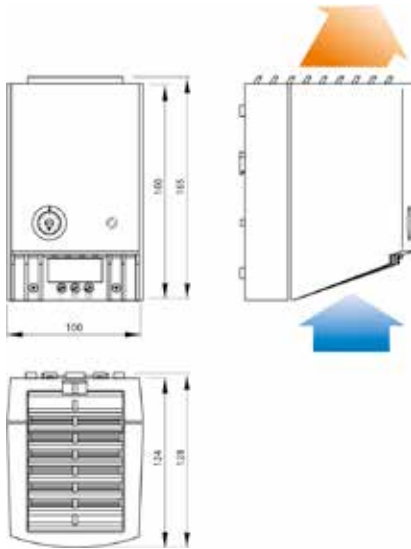

Heating capacity / Ambient temperature diagram
CR 027 (50 Hz)

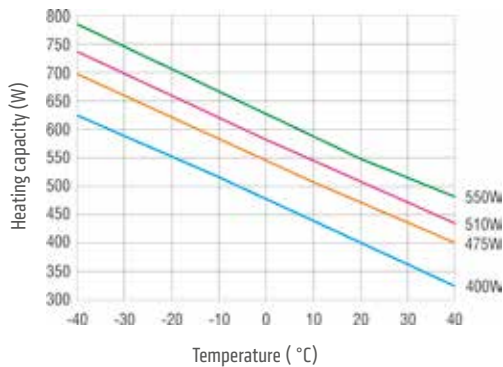

Heating capacity / Ambient temperature diagram
CR 027 (60 Hz)

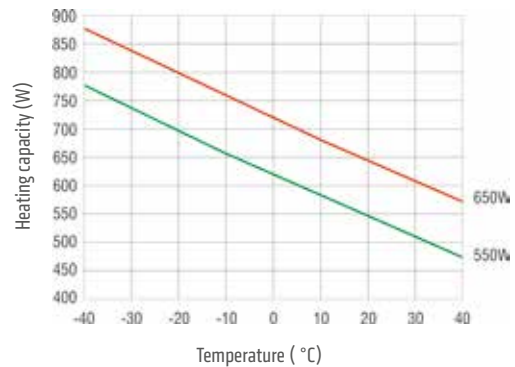

Art. No.	Operating voltage	Heating capacity ¹ (50 Hz)	Heating capacity ¹ (60 Hz)	Inrush current max.	Recommended pre- fuse T (time-delay)	Airflow, free flow	Setting range thermostat ²	Weight (approx.)
02700.0-00	AC 220 – 240 V, 50/60 Hz	475 W	550 W	11.0 A	10.0 A	35 m ³ /h	0 to +60 °C	0.9 kg
02701.0-00	AC 220 – 240 V, 50/60 Hz	550 W	650 W	13.0 A	10.0 A	45 m ³ /h	0 to +60 °C	1.1 kg
02700.9-00	AC 100 – 120 V, 50/60 Hz	400 W	550 W	14.0 A	10.0 A	35 m ³ /h	+32 to +140 °F	0.9 kg
02701.9-00	AC 100 – 120 V, 50/60 Hz	510 W	650 W	15.0 A	10.0 A	45 m ³ /h	+32 to +140 °F	1.1 kg

¹ at +20 °C (+68 °F) ambient temperature; ² Switch temperature difference 7 K (±4 K tolerance)

SPACE-SAVING FAN HEATER

HVI 030 | 500 W to 700 W

- > Compact
- > Flat design

- > Temperature safety cut-out
- > Twist clip or screw fixing



The compact high-performance fan heater prevents formation of condensation and frost and provides an evenly distributed interior air temperature in enclosures with electric/electronic components. The heater may only be operated together with fan, but is also available without axial fan (for self-installation). The fan heaters are available with two different mounting systems – either mounting by screw fixing or with a new and unique twist clip mounting system. These options allow for a quick and easy installation of the fan heater.



TECHNICAL DATA

Heating element	high performance cartridge
Temperature safety cut-out	with automatic reset and second-tier one shot fuse to protect against overheating in case of fan failure
Axial fan	not included in delivery, for self-assembly
Connection	2-pole dual pressure clamp for rigid wire 2.5 mm ² , stranded wire (with wire end ferrule) 1.5 mm ²
Casing	plastic according to UL94 V-0, black
Mounting	twist clip for 35 mm DIN rail, EN 60715 or screw fixing (M6), torque 2 Nm max., washers have to be used
Fitting position	vertical airflow (air outlet up)
Dimensions	169 x 127 x 45 mm
Weight	approx. 0.7 kg
Operating temperature	VDE: -10 to +50 °C (+14 to +122 °F) UL: -10 to +40 °C (+14 to +104 °F)
Storage temperature	-45 to +70 °C (-49 to +158 °F)
Operating/Storage humidity	max. 90 % RH (non-condensing)
Protection type/Protection class	IP20 / II (double insulated)
Approvals	VDE, UL File No. E234324, EAC
Note	other heating capacities and voltages available on request

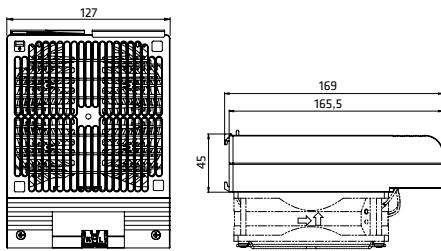

View: back side

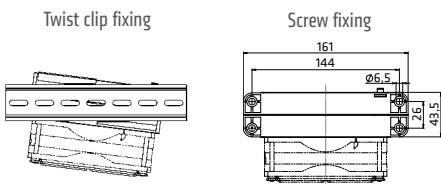

Twist clip fixing

Screw fixing



Important note: Heater may only be operated together with fan (min. 150 m³/h). Danger of overheating!

Art. No. twist clip fixing	Art. No. screw fixing	Operating voltage	Heating capacity	Recommended pre-fuse T (time-delay)
03074.0-00	03074.0-01	AC 230 V, 50/60 Hz	500 W	4.0 A
03073.0-00	03073.0-01	AC 230 V, 50/60 Hz	600 W	4.0 A
03072.0-00	03072.0-01	AC 230 V, 50/60 Hz	700 W	6.3 A
03074.9-00	03074.9-01	AC 120 V, 50/60 Hz	500 W	8.0 A
03073.9-00	03073.9-01	AC 120 V, 50/60 Hz	600 W	8.0 A
03072.9-00	03072.9-01	AC 120 V, 50/60 Hz	700 W	10.0 A

SPACE-SAVING FAN HEATER WITH FAN

HVI 030 | 500 W to 700 W



- > Compact
- > Flat design
- > High air through-flow
- > Temperature safety cut-out
- > Twist clip or screw fixing

The compact high-performance fan heater prevents formation of condensation and frost and provides an evenly distributed interior air temperature in enclosures with electric/electronic components. The heater may only be operated together with fan, but is also available without axial fan (for self-installation). The fan heaters are available with two different mounting systems – either mounting by screw fixing or with a new and unique twist clip mounting system. These options allow for a quick and easy installation of the fan heater.



TECHNICAL DATA

Heating element	high performance cartridge
Temperature safety cut-out	with automatic reset and second-tier one shot fuse to protect against overheating in case of fan failure
Axial fan, ball bearing	airflow 150 m ³ /h, free flow service life 50,000 h at +25 °C (+77 °F)
Connection	3-pole dual pressure clamp for rigid wire 2.5 mm ² , stranded wire (with wire end ferrule) 1.5 mm ²
Casing	plastic according to UL94 V-0, black
Mounting	twist clip for 35 mm DIN rail, EN 60715 or screw fixing (M6), torque 2 Nm max., washers have to be used
Fitting position	vertical airflow (air outlet up)
Dimensions	169 x 127 x 89 mm
Weight	approx. 1.3 kg
Operating temperature	VDE: -10 to +50 °C (+14 to +122 °F) UL: -10 to +40 °C (+14 to +104 °F)
Storage temperature	-45 to +70 °C (-49 to +158 °F)
Operating/Storage humidity	max. 90 % RH (non-condensing)
Protection type/Protection class	IP20 / heater: II (double insulated); fan: I (earthed)
Approvals	VDE, UL File No. E234324, EAC
Note	other heating capacities and voltages available on request

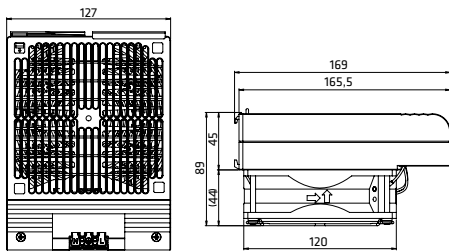

View: back side

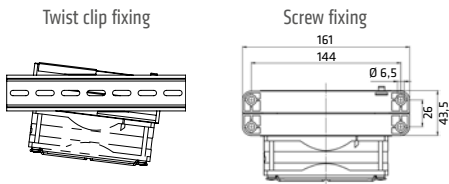

Important note: Heater may only be operated together with fan (min. 150 m³/h). Danger of overheating!

Art. No. twist clip fixing	Art. No. screw fixing	Operating voltage	Heating capacity	Recommended pre-fuse T (time-delay)
03084.0-00	03084.0-01	AC 230 V, 50/60 Hz	500 W	4.0 A
03083.0-00	03083.0-01	AC 230 V, 50/60 Hz	600 W	4.0 A
03082.0-00	03082.0-01	AC 230 V, 50/60 Hz	700 W	6.3 A
03084.9-00	03084.9-01	AC 120 V, 50/60 Hz	500 W	8.0 A
03083.9-00	03083.9-01	AC 120 V, 50/60 Hz	600 W	8.0 A
03082.9-00	03082.9-01	AC 120 V, 50/60 Hz	700 W	10.0 A

COMPACT HIGH-PERFORMANCE FAN HEATER

CR 030 | 950 W



- > Compact design
- > Double insulated

> Integrated thermostat or hygrostat

The compact high performance fan heater prevents formation of condensation and frost and provides an evenly distributed interior air temperature in enclosures with electric/electronic components. The plastic housing provides double insulation and acts as protection against contact. The fan heater is available with integrated thermostat or pre-set hygrostat for temperature or humidity control. The CR 030 was designed as a stationary unit for the bottom of the enclosure. For wall fixing the fan heater CR 130 is recommended.



TECHNICAL DATA

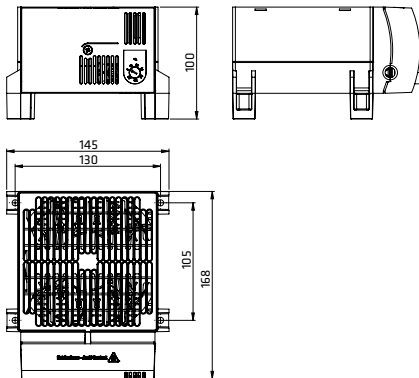

Heating element	high performance cartridge
Temperature safety cut-out	with automatic reset and second-tier one shot fuse to protect against overheating in case of fan failure
Heater body	extruded aluminium profile
Axial fan, ball bearing	airflow 160 m ³ /h, free flow service life 50,000 h at +25 °C (+77 °F)
Connection	2-pole max. 2.5 mm ² , clamping screw with strain relief, torque 0.8 Nm max.
Casing	plastic according to UL94 V-0, black
Mounting	screw fixing (M5)
Fitting position	vertical airflow (air outlet up)
Dimensions	168 x 145 x 100 mm
Weight	approx. 1.4 kg
Operating ¹ /Storage temperature	-45 to +70 °C (-49 to +158 °F)
Operating/Storage humidity	max. 90 % RH (non-condensing)
Protection type/Protection class	IP20 / II (double insulated)
Note	other heating capacities from 200 W up available on request

¹ Operating temperature of heater with integrated hygrostat: 0 to +60 °C (+32 to +140 °F).

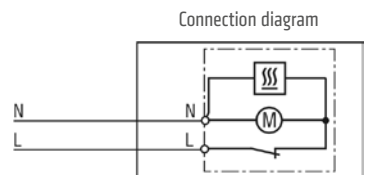

Art. No.	Model	Operating voltage	Heating capacity	Recommended pre-fuse T (time-delay)	Setting range ²	Approvals		
03051.0-00	Fan Heater with thermostat	AC 230 V, 50/60 Hz	950 W	6.3 A	0 to +60 °C	VDE	UL File No. E234324	EAC
03051.0-02	Fan Heater with hygrostat	AC 230 V, 50/60 Hz	950 W	6.3 A	65 % RH, factory-set	VDE	UL File No. E234324	EAC
03059.9-00	Fan Heater with thermostat	AC 120 V, 50/60 Hz	950 W	10.0 A	+32 to +140 °F	-	UL File No. E234324	EAC

² Switch temperature difference 7 K (±4 K tolerance)

COMPACT HIGH-PERFORMANCE FAN HEATER

CR 130 | 950 W



- > Compact design
- > Double insulated

- > Integrated thermostat or hygrostat
- > Optional clip or screw fixing

The compact high performance fan heater prevents formation of condensation and frost and provides an evenly distributed interior air temperature in enclosures with electric/electronic components. The plastic housing provides double insulation and acts as protection against contact. The fan heater is available with integrated thermostat or pre-set hygrostat for temperature or humidity control. The CR 130 was designed as a stationary unit for wall fixing. For fixing on the bottom of the enclosure the fan heater CR 030 is recommended.



TECHNICAL DATA

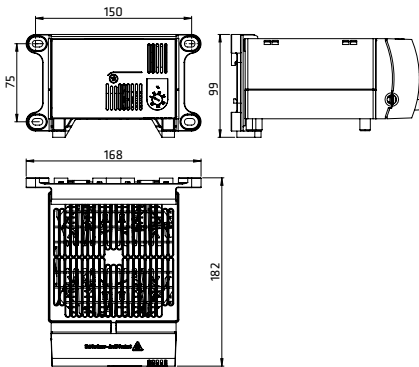

Heating element	high performance cartridge
Temperature safety cut-out	with automatic reset and second-tier one shot fuse to protect against overheating in case of fan failure
Heater body	extruded aluminium profile
Axial fan, ball bearing	airflow 160 m ³ /h, free flow, service life 50,000 h at +25 °C (+77 °F)
Connection	2-pole max. 2.5 mm ² , clamping screw with strain relief, torque 0.8 Nm max.
Casing	plastic according to UL94 V-0, black
Mounting	clip for 35 mm DIN rail, EN 60715 or screw fixing (M6)
Fitting position	vertical airflow (air outlet up)
Dimensions	182 x 168 x 99 mm
Weight	approx. 1.5 kg
Operating ¹ /Storage temperature	-45 to +70 °C (-49 to +158 °F)
Operating/Storage humidity	max. 90 % RH (non-condensing)
Protection type/Protection class	IP20 / II (double insulated)
Note	other heating capacities from 200 W up available on request

¹ Operating temperature of heater with integrated hygrostat: 0 to +60 °C (+32 to +140 °F)

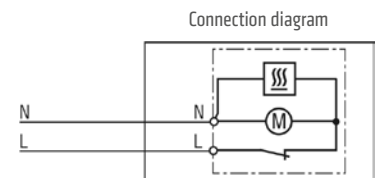

Art. No.	Model	Operating voltage	Heating capacity	Recommended pre-fuse T (time-delay)	Setting range ²	Approvals		
13051.0-00	Fan Heater with thermostat	AC 230 V, 50/60 Hz	950 W	6.3 A	0 to +60 °C	VDE	UL File No. E234324	EAC
13051.0-02	Fan Heater with hygrostat	AC 230 V, 50/60 Hz	950 W	6.3 A	65 % RH, factory-set	VDE	UL File No. E234324	EAC
13059.9-00	Fan Heater with thermostat	AC 120 V, 50/60 Hz	950 W	10.0 A	+32 to +140 °F	-	UL File No. E234324	EAC

² Switch temperature difference 7 K (±4 K tolerance)

HIGH-PERFORMANCE FAN HEATER (SEMICONDUCTOR)

CS 032 / CSF 032 | 1,000 W



Fan heater CS 032



Fan heater CSF 032

- > Compact and slim design
- > High heating performance
- > Double insulated
- > With or without thermostat
- > Quick connection

The compact high performance fan heater prevents formation of condensation and frost and provides an evenly distributed interior air temperature in enclosures with electric/electronic components. The plastic housing provides double insulation and acts as protection against contact. Two screw connectors at the front of CS 032 allow comfortable wiring of an external thermostat. The CSF 032 is equipped with a pre-set thermostat. Both models were designed for wall fixing. A fan heater for fixing on the bottom of the enclosure is available on request.



TECHNICAL DATA

Heating element	PTC resistor – temperature limiting
Surface temperature	max. +80 °C (+176 °F), except upper protective grille at +20 °C (+68 °F) ambient temperature
Temperature safety cut-out	to protect against overheating in case of fan failure, automatic reset
Axial fan, ball bearing	air flow 63 m ³ /h, free flow service life 70,000 h at 25 °C (77 °F)
Connection	male power insert connector according to IEC320 C18
Casing	plastic according to UL94 V-0, black
Mounting	clip for 35 mm DIN rail, EN 60715 or screw fixing (M5), tightening torque 2 Nm max.
Fitting position	airflow direction up
Dimensions	152.5 x 88 x 66 mm
Weight	approx. 0.5 kg
Operation/Storage temperature	-40 to +60 °C (-40 to +140 °F) / -40 to +70 °C (-40 to +158 °F)
Operation/Storage humidity	max. 90 % RH (non-condensing)
Protection type/Protection class	IP20 / II (double insulated)
Approvals	VDE, UL File No. E234324, EAC

Important note: Connectors and cables for electrical connection are not included in the delivery. Connection cables can be ordered separately, see Accessories.

FAN HEATER CS 032 (WITHOUT THERMOSTAT)

Art. No. Clip fixing	Art. No. Screw fixing	Operating voltage	Heating capacity ¹	Inrush current max.
03209.0-00	03209.0-01	AC 220 – 240 V, 50/60 Hz	1,000 W	12.0 A
03209.9-00	03209.9-01	AC 100 – 120 V, 50/60 Hz	1,000 W	18.0 A

FAN HEATER CSF 032 (WITH THERMOSTAT)

Art. No. Clip fixing	Art. No. Screw fixing	Operating voltage	Heating capacity ¹	Inrush current max.	Switch-off temperature ²	Switch-on temperature ²
03201.0-00	03201.0-01	AC 220 – 240 V, 50/60 Hz	1,000 W	12.0 A	+25 °C (+77 °F)	+15 °C (+59 °F)
03202.0-00	03202.0-01	AC 220 – 240 V, 50/60 Hz	1,000 W	12.0 A	+15 °C (+59 °F)	+5 °C (+41 °F)
03201.9-00	03201.9-01	AC 100 – 120 V, 50/60 Hz	1,000 W	18.0 A	+25 °C (+77 °F)	+15 °C (+59 °F)
03202.9-00	03202.9-01	AC 100 – 120 V, 50/60 Hz	1,000 W	18.0 A	+15 °C (+59 °F)	+5 °C (+41 °F)

¹ at +25 °C (+77 °F) ambient temperature; ² tolerance ±5 K
Note: Other switch-off and switch-on temperatures on request.

TECHNICAL DRAWING

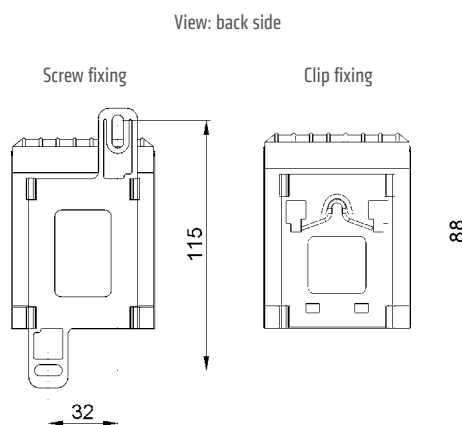
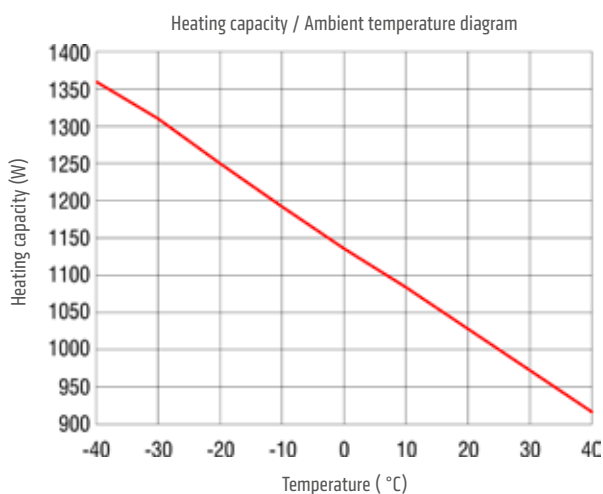
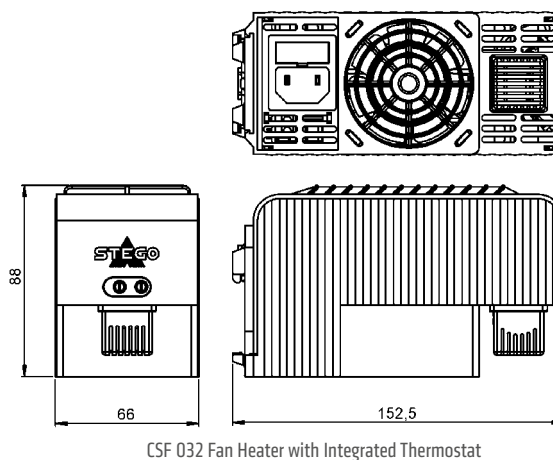
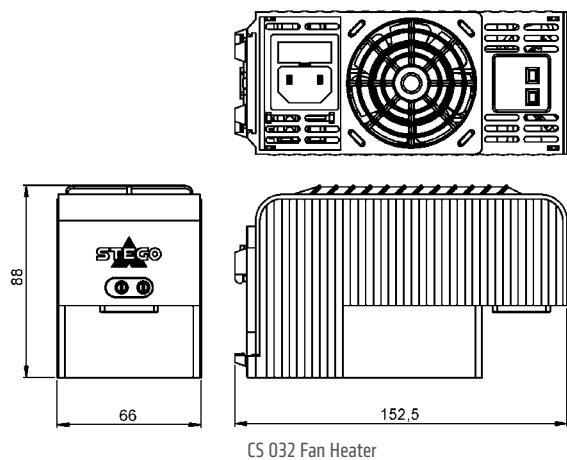

ACCESSORIES

Connection cable with female power insert connector according IEC320 C17

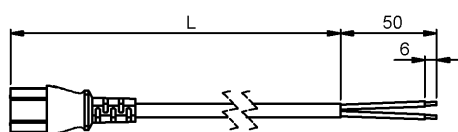

Art. No.	Length (L)
244379	1.0 m
244380	2.0 m

Retaining Clip



Photo: Retaining Clip art. no. 237009 in built-in state

Art. No.	Note
237009	Suitable for female power insert connector on connection cable 244379 and 244380

COMPACT HIGH-PERFORMANCE FAN HEATER (SEMICONDUCTOR)

CS 030 | 1,200 W



- > Compact design
- > Double insulated
- > High heating performance
- > Integrated thermostat (optional)

The compact high performance fan heater prevents formation of condensation and frost and provides an evenly distributed interior air temperature in enclosures with electric/electronic components. The plastic housing provides double insulation and acts as protection against contact. The fan heater is available with optional integrated thermostat for temperature control. The CS 030 was designed as a stationary unit for the bottom of the enclosure. For wall fixing the fan heater CS 130 is recommended.



TECHNICAL DATA

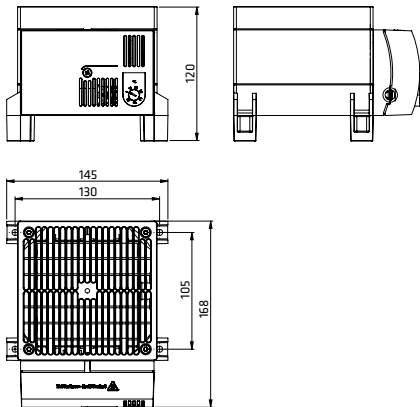

Heating element	PTC resistor – temperature limiting
Temperature safety cut-out	to protect against overheating in case of fan failure, automatic reset
Axial fan, ball bearing	airflow 160 m ³ /h, free flow service life 50,000 h at +25 °C (+77 °F)
Connection	2-pole max. 2.5 mm ² , clamping screw with strain relief, torque 0.8 Nm max.
Casing	plastic according to UL94 V-0, black
Mounting	screw fixing (M5)
Fitting position	vertical airflow (air outlet up)
Dimensions	168 x 145 x 120 mm
Weight	approx. 1.2 kg
Operating/Storage temperature	-45 to +70 °C (-49 to +158 °F)
Operating/Storage humidity	max. 90 % RH (non-condensing)
Protection type/Protection class	IP20 / II (double insulated)

Connection diagram

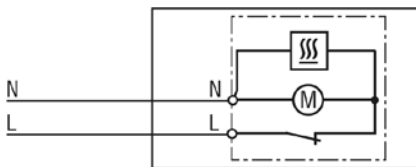

Heating capacity / Ambient temperature diagram CS 030

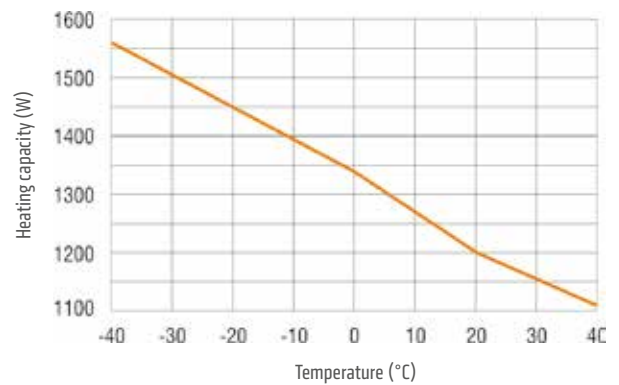

Art. No.	Model	Operating voltage	Heating capacity ¹	Inrush current max.	Recommended pre-fuse T (time-delay)	Setting range ²	Approvals		
03060.0-00	Fan Heater with thermostat	AC 230 V, 50/60 Hz	1,200 W	13.0 A	10.0A	0 to +60 °C	VDE	UL File No. E150057 ³	EAC
03060.0-01	Fan Heater without thermostat	AC 230 V, 50/60 Hz	1,200 W	13.0 A	10.0A	-	VDE	UL File No. E150057 ³	EAC
03060.9-00	Fan Heater with thermostat	AC 120 V, 50/60 Hz	1,200 W	16.0 A	16.0A	+32 to +140 °F	-	UL File No. E150057 ³	EAC
03060.9-01	Fan Heater without thermostat	AC 120 V, 50/60 Hz	1,200 W	16.0 A	16.0A	-	-	UL File No. E150057 ³	EAC

¹ at +20 °C (+68 °F) ambient temperature; ² Switch temperature difference 7 K (±4 K tolerance); ³ according to UL 508A, NITW File on request

COMPACT HIGH-PERFORMANCE FAN HEATER (SEMICONDUCTOR)

CS 130 | 1,200 W



- > Compact design
- > High heating performance
- > Double insulated
- > Integrated thermostat (optional)
- > Optional clip or screw fixing

The compact high performance fan heater prevents formation of condensation and frost and provides an evenly distributed interior air temperature in enclosures with electric/electronic components. The plastic housing provides double insulation and acts as protection against contact. The fan heater is available with optional integrated thermostat for temperature control. The CS 130 was designed as a stationary unit for wall fixing. For fixing on the bottom of the enclosure the fan heater CS 030 is recommended.



TECHNICAL DATA

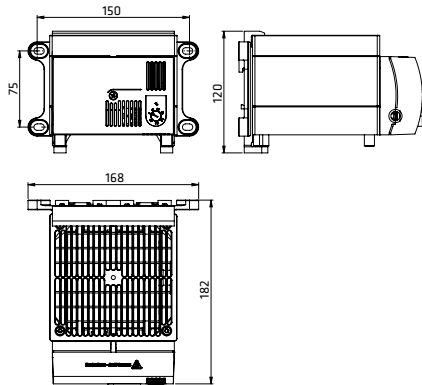

Heating element	PTC resistor – temperature limiting
Temperature safety cut-out	to protect against overheating in case of fan failure, automatic reset
Axial fan, ball bearing	airflow 160 m ³ /h, free flow service life 50,000 h at +25 °C (+77 °F)
Connection	2-pole max. 2.5 mm ² , clamping screw with strain relief, torque 0.8 Nm max.
Casing	plastic according to UL94 V-0, black
Mounting	clip for 35 mm DIN rail, EN 60715 or screw fixing (M6)
Fitting position	vertical airflow (air outlet up)
Dimensions	182 x 168 x 120 mm
Weight	approx. 1.3 kg
Operating/Storage temperature	-45 to +70 °C (-49 to +158 °F)
Operating/Storage humidity	max. 90 % RH (non-condensing)
Protection type/Protection class	IP20 / II (double insulated)

Connection diagram

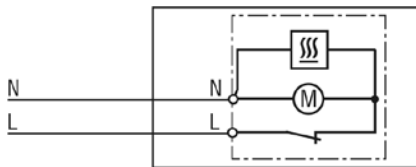

Heating capacity / Ambient temperature diagram CS 130

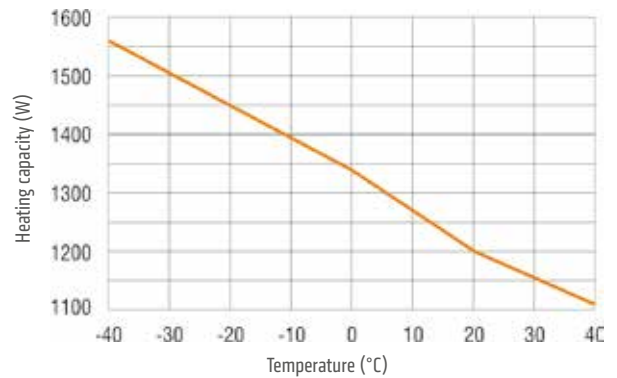

Art. No.	Model	Operating voltage	Heating capacity ¹	Inrush current max.	Recommended pre-fuse T (time-delay)	Setting range ²	Approvals
13060.0-00	Fan Heater with thermostat	AC 230 V, 50/60 Hz	1,200 W	13.0 A	10.0 A	0 to +60 °C	VDE UL File No. E150057 ³ EAC
13060.0-01	Fan Heater without thermostat	AC 230 V, 50/60 Hz	1,200 W	13.0 A	10.0 A	-	VDE UL File No. E150057 ³ EAC
13060.9-00	Fan Heater with thermostat	AC 120 V, 50/60 Hz	1,200 W	16.0 A	16.0 A	+32 to +140 °F	- UL File No. E150057 ³ EAC
13060.9-01	Fan Heater without thermostat	AC 120 V, 50/60 Hz	1,200 W	16.0 A	16.0 A	-	- UL File No. E150057 ³ EAC

¹ at +20 °C (+68 °F) ambient temperature; ² Switch temperature difference 7 K (±4 K tolerance); ³ according to UL 508A, NITW File on request

HIGH-PERFORMANCE FAN HEATER

DCR 030 | DC 24 V, DC 56 V – 200 W to 800 W



- > High DC heating performance
- > Integrated thermostat or hygrostat (optional)
- > Small hysteresis
- > Integrated switch module
- > Screw fixing
- > Optical indicator (LED)

The compact high performance fan heater prevents formation of condensation and frost and provides an evenly distributed interior air temperature in enclosures with electric/electronic components. The fan heater is available with an integrated electronic thermostat or integrated electronic hygrostat. The model with thermostat is available with internal or external sensor. The fan heater with integrated hygrostat is equipped with an external sensor. The external sensor can be positioned freely anywhere in the enclosure for precise measurements of temperature and humidity. The DCR 030 was designed as a stationary unit for the bottom of the enclosure. For wall fixing the fan heater DCR 130 is recommended.



TECHNICAL DATA

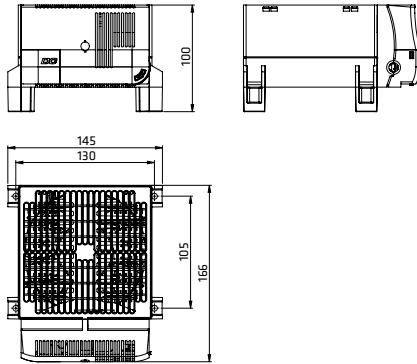

Heating element	high performance cartridge
Temperature safety cut-out	with automatic reset and second-tier one shot fuse to protect against overheating in case of fan failure
Heater body	extruded aluminium profile
Axial fan, ball bearing	airflow 160 m ³ /h, free flow service life 50,000 h at +25 °C (+77 °F)
Connection	2-pole „Push-In“ connection clamp stranded wire ¹ 1.5 mm ² (AWG 16) with strain relief; max. 2.5 mm ² (AWG 12)
Casing	plastic according to UL94 V-0, black
Mounting	screw fixing (M5), torque 2 Nm max., washers have to be used
Fitting position	vertical airflow (air outlet up)
Dimensions	166 x 145 x 100 mm
Weight	approx. 1.3 kg
Operating temperature	-20 to +75 °C (-4 to +167 °F)
Storage temperature	-40 to +80 °C (-40 to +176 °F)
Operating / Storage humidity	max. 90 % RH (non-condensing)
Protection type / Protection class	IP20 / II (double insulated)
Approvals	UL File No. E234324, VDE, EAC
Note	other versions (heating capacities, setting ranges) as well as operating voltage DC 48 V on request

¹ When connecting with stranded wires, wire end ferrules must be used.

Connection diagram

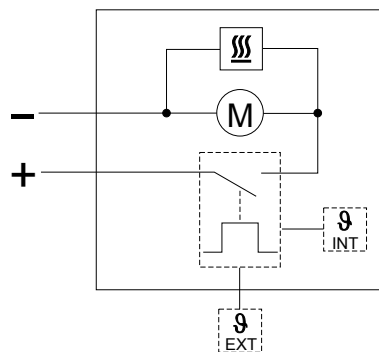

Art. No.	Model	Operating voltage	Heating capacity	Recommended pre-fuse T (time-delay)	Setting range ³ temperature / humidity
03092.1-12	Thermostat with internal sensor	DC 24 V	200 W	25.0 A	-20 to +40 °C
03092.1-13	Thermostat with connector for external sensor ²	DC 24 V	200 W	25.0 A	-20 to +40 °C
03097.3-12	Thermostat with internal sensor	DC 56 V	800 W	25.0 A	-20 to +40 °C
03097.3-13	Thermostat with connector for external sensor ²	DC 56 V	800 W	25.0 A	-20 to +40 °C
03092.1-03	Hygrostat with connector for external sensor ²	DC 24 V	200 W	25.0 A	40 to 90 % RH
03095.3-03	Hygrostat with connector for external sensor ²	DC 56 V	600 W	25.0 A	40 to 90 % RH

² The external sensor needs to be ordered separately.

³ Switch difference temperature: 3 K (±1 K tolerance) at +25 °C (+77 °F), 50 % RH; switch difference humidity: 4 % RH (±1 % tolerance) at +25 °C (+77 °F), 50 % RH.

ACCESSORIES

The external sensor is not included in the delivery of the DCR 030. It can be ordered separately.

EXTERNAL SENSOR

The external sensor can be positioned freely anywhere in the enclosure for precise measurements of temperature and humidity.

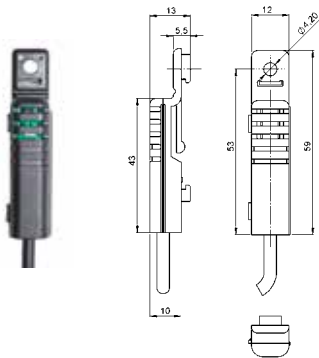

Art. No.	Length
267071	1 m
267072	2 m
267126	3 m

HIGH-PERFORMANCE FAN HEATER

DCR 130 | DC 24 V, DC 56 V – 200 W to 800 W



- > High DC heating performance
- > Integrated thermostat or hygrostat (optional)
- > Small hysteresis
- > Integrated switch module
- > Optional clip or screw fixing
- > Optical indicator (LED)

The compact high performance fan heater prevents formation of condensation and frost and provides an evenly distributed interior air temperature in enclosures with electric/electronic components. The fan heater is available with an integrated electronic thermostat or electronic hygrostat. The model with thermostat is available with internal or external sensor. The fan heater with integrated hygrostat is equipped with an external sensor. The external sensor can be positioned freely anywhere in the enclosure for precise measurements of temperature and humidity. The DCR 130 was designed for wall fixing. For fixing on the bottom of the enclosure the fan heater DCR 030 is recommended.



TECHNICAL DATA

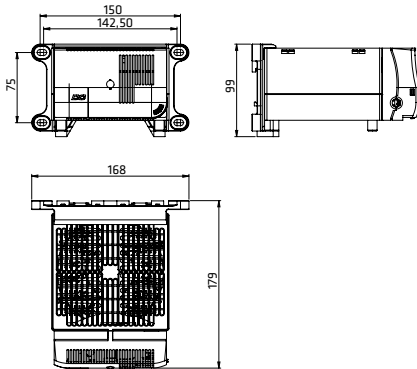

Heating element	high performance cartridge
Temperature safety cut-out	with automatic reset and second-tier one shot fuse to protect against overheating in case of fan failure
Heater body	extruded aluminium profile
Axial fan, ball bearing	airflow 160 m ³ /h, free flow service life 50,000 h at +25 °C (+77 °F)
Connection	2-pole „Push-In“ connection clamp stranded wire ¹ 1.5 mm ² (AWG 12) with strain relief; max. 2.5 mm ² (AWG 12)
Casing	plastic according to UL94 V-0, black
Mounting	clip for 35 mm DIN rail, EN 60715 or screw fixing (M6), torque 2 Nm max., washers have to be used
Fitting position	vertical airflow (air outlet up)
Dimensions	179 x 168 x 99 mm
Weight	approx. 1.3 kg
Operating temperature	-20 to +75 °C (-4 to +167 °F)
Storage temperature	-40 to +80 °C (-40 to +176 °F)
Operating / Storage humidity	max. 90 % RH (non-condensing)
Protection type / Protection class	IP20 / II (double insulated)
Approvals	UL File No. E234324, VDE, EAC
Note	other versions (heating capacities, setting ranges) as well as operating voltage DC 48 V on request

¹ When connecting with stranded wires, wire end ferrules must be used.

Connection diagram

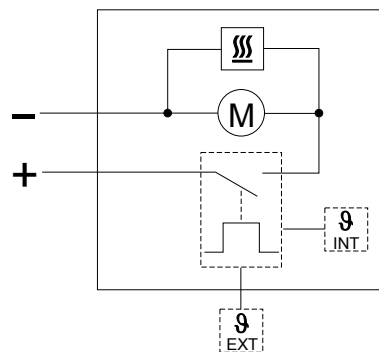

Art. No.	Model	Operating voltage	Heating capacity	Recommended pre-fuse T (time-delay)	Setting range ³ temperature / humidity
13092.1-12	Thermostat with internal sensor	DC 24 V	200 W	25.0 A	-20 to +40 °C
13092.1-13	Thermostat with connector for external sensor ²	DC 24 V	200 W	25.0 A	-20 to +40 °C
13097.3-12	Thermostat with internal sensor	DC 56 V	800 W	25.0 A	-20 to +40 °C
13097.3-13	Thermostat with connector for external sensor ²	DC 56 V	800 W	25.0 A	-20 to +40 °C
13092.1-03	Hygrostat with connector for external sensor ²	DC 24 V	200 W	25.0 A	40 to 90 % RH
13095.3-03	Hygrostat with connector for external sensor ²	DC 56 V	600 W	25.0 A	40 to 90 % RH

² The external sensor needs to be ordered separately.

³ Switch difference temperature: 3 K (±1 K tolerance) at +25 °C (+77 °F), 50 % RH; switch difference humidity: 4 % RH (±1 % tolerance) at +25 °C (+77 °F), 50 % RH.

ACCESSORIES

The external sensor is not included in the delivery of the DCR 130. It can be ordered separately.

EXTERNAL SENSOR

The external sensor can be positioned freely anywhere in the enclosure for precise measurements of temperature and humidity.

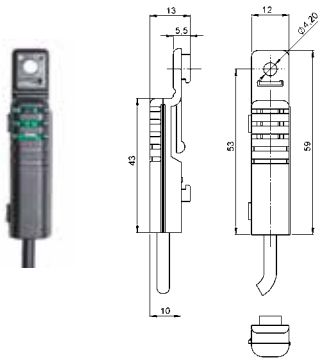

Art. No.	Length
267071	1 m
267072	2 m
267126	3 m



COOLING

PROTECTION AGAINST OVERHEATING

To protect installations from excessively high temperatures STEGO filter fans ensure efficient cooling by circulating air.

INNOVATIVE VENTILATING TECHNOLOGY FOR ENCLOSURES: FILTER FAN PLUS COOLS WITH A 'PLUS' OF AIR

Optimum usage of space is always important in systems with electric or electronic components. Sophisticated enclosure applications often come with a high density of components. High temperatures within the enclosure may cause malfunctions if not addressed. With STEGO's new Filter Fan Plus and its innovative air-flap outlet technology you are safe in the knowledge that sensitive components, in all kinds of applications, are safeguarded against overheating and malfunction.

➤ NEW AIR-FLAP OUTLET TECHNOLOGY FOR ENHANCED AIRFLOW



The new air-flap outlet technology eliminates the need for the filter mat for the air outlet, enhancing in turn the exiting airflow. So, using the same cut-out in an enclosure wall more air can be exchanged. Leading to more efficient cooling of the application. Another advantage: The flaps stay closed and dirt stays out when the fan is not in operation.

➤ SECURE AND STABLE: TOOL-FREE RATCHET MOUNT MECHANISM



The Filter Fan Plus is placed in the enclosure cut-out from the outside of the enclosure and mounted tool-free. By pressing the built-in ratchet braces the filter fan is pulled into the cabinet wall. The ratchet braces snap into place, giving the installer audible feedback that the filter fan is now installed securely. The ratchet mount is suitable for a wall thickness from 1 to 4 mm.

➤ ONLY ONE FILTER MAT SAVES COSTS

Flaps instead of mats: In contrast to conventional systems the Filter Fan Plus only requires one filter mat. This reduces maintenance work and costs.

➤ IP54 | UL TYPE 12 | NEMA 12 DUST AND SPLASH WATER PROTECTION

The new Filter Fan Plus protects against dust and splash water. Proven by successfully completed protection type tests carried-out by independent testing and certification agencies, like VDE and Underwriters Laboratories (UL).

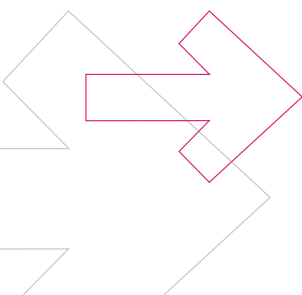

IN OR OUT?

MORE AIRFLOW IN ANY CASE.

With its unique technology, the Filter Fan Plus achieves a more effective air circulation and offers a considerable plus in airflow. The result: A noticeable increase in cool air gets into the enclosure. At the same time, warm air is expelled faster and more effectively to the outside.

The Filter Fan Plus is available in two high performance systems, ensuring the right combination to suit every application.

SYSTEM FPI AIRFLOW DIRECTION „IN“

This is the more common approach: a filter fan with filter mat is located in the lower part of the enclosure and draws air from the outside. The air rises to the top of the enclosure, cooling the internal space and pushing the warm interior air through the air outlet. Whereas this air outlet now pulls more effectively, thanks to our new air-flap outlet technology.

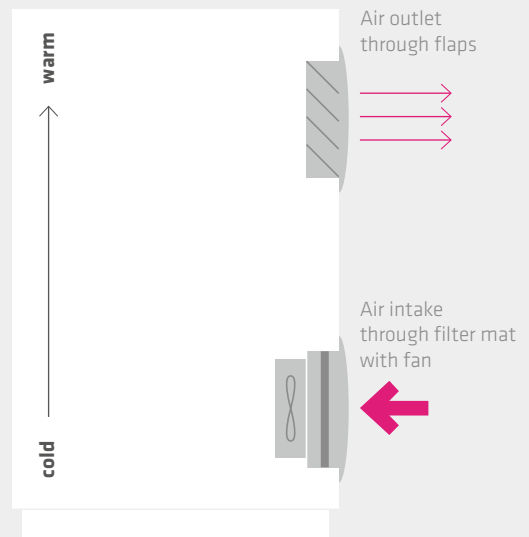

SYSTEM FPO AIRFLOW DIRECTION „OUT“

In this alternative approach, where it may be necessary to expel heat build-up more directly from the upper part of the enclosure, we recommend a more active evacuation of the hot air. For this purpose the fan in combination with the effective flap technology is placed in the upper part of the cabinet. The heat can be diverted quicker from the critical area. An intake filter with mat is needed in the lower part of the enclosure to allow the colder air from the outside to enter.

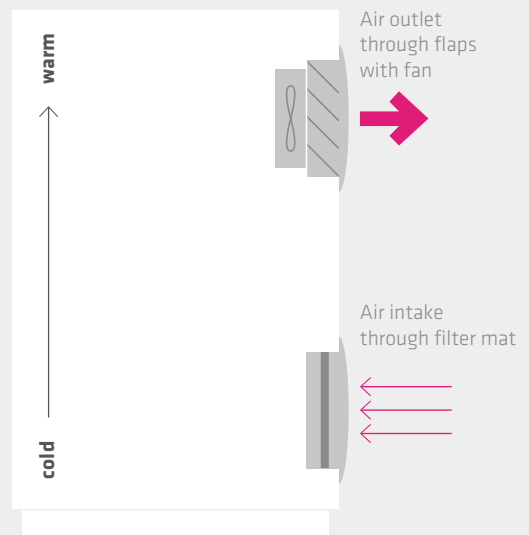

FILTER FAN PLUS

FPI/FPO 018 | up to 24 m³/h (92 x 92 mm)



- > New air-flap outlet technology for high airflow
- > Easy mounting
- > Protection type test/Environmental rating by independent testing institutes (VDE and UL)
- > Two systems for optimal airflow (FPI/FPO)
- > Standard enclosure cut-out sizes (5 sizes)
- > One filter mat

Filter fans are used to provide an optimum climate in enclosures and cabinets with electrical/electronic components. The interior temperature of an enclosure can be reduced by channelling cooler filtered outside air into the enclosure thus expelling heated internal air. The resulting airflow prevents formation of localised hot pockets in installations and protects electronic components from overheating.

The Filter Fan Plus series uses a new air-flap outlet technology for the air outlet and thus reaches a high degree of airflow. A ratchet mechanism is used for mounting and provides high stability and tightness. Depending on the application there are two systems that are available – the FPI or FPO system. The FPI system is a standard installation with a filter fan in the lower part of the enclosure which ensures that fresh air is fed into the enclosure (airflow direction "In"). This system consists of a filter fan and exit filter. Whereas in the FPO system, the filter fan is located in the upper area of the enclosure to avoid heat buildups (airflow direction "Out"). The FPO system is composed of an intake filter and exit filter fan. The Filter Fan Plus series may also be used outdoors with appropriate protective measures or when equipped with weather proof accessories, e.g. Hose-proof Hood FFH 086.

SYSTEM FPI

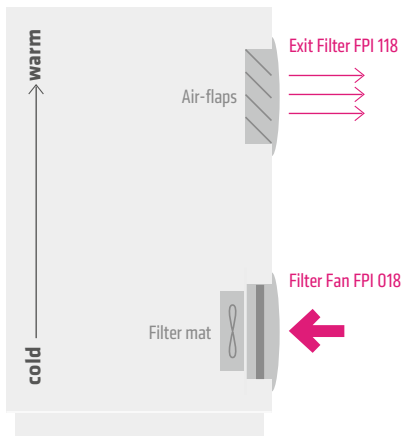

TECHNICAL DATA



Axial fan, ball bearing	service life L10 at +40 °C (+104 °F): min. 50,000 h fan body aluminium, rotor metal
Connection	2 stranded wires, 300 mm
Casing, hood, flaps	plastic according to UL94 V-0, light grey; UV light resistant according to UL746C (f1)
Enclosure cut-out	92 x 92 ¹ mm
Mounting frame	4 built-in ratchet braces for mounting (6 notches for wall thickness 1 – 4 mm). Additional use of screws possible if needed ¹ .
Filter mat	ISO coarse 55 % acc. to ISO 16890 (G3), initial gravimetric arrestance 57 %
Filter material	synthetic fibre with progressive construction, temperature resistant to +100 °C, self-extinguishing class F1, moisture resistant to 100 % RH, reusable
Operating/Storage temperature	-40 to +70 °C (-40 to +158 °F)
Operating/Storage humidity	max. 90 % RH (non-condensing)
Protection type/Protection class	IP54 / I (earthed)
Environmental rating UL/NEMA	UL TYPE 12 / NEMA 12
Approvals	VDE, UL File No. E234324, EAC
Note	other voltages on request

¹ Drilling marks for screw mounting are indicated on mounting frame.

AIRFLOW DIRECTION "IN": FILTER FAN FPI 018

Art. No.	Operating voltage	Air volume, free flow	Air volume with exit filter	Current consumption (50/60 Hz)	Power consumption	Average noise level (DIN EN ISO 4871)	Depth in enclosure	Weight (approx.)	Filter mat
01870.0-30	AC 230 V, 50/60 Hz	19 m ³ /h	13 m ³ /h	70 mA	12 W	39 db (A)	66 mm	0.6 kg	G3
01870.9-30	AC 115 V, 50/60 Hz	23 m ³ /h	16 m ³ /h	115 mA	11 W	43 db (A)	66 mm	0.6 kg	G3

AIRFLOW DIRECTION "IN": EXIT FILTER FPI 118

Art. No.	Depth in enclosure	Weight (approx.)	Air outlet
11870.0-00	29 mm	0.2 kg	air-flap outlet technology

SYSTEM FPO

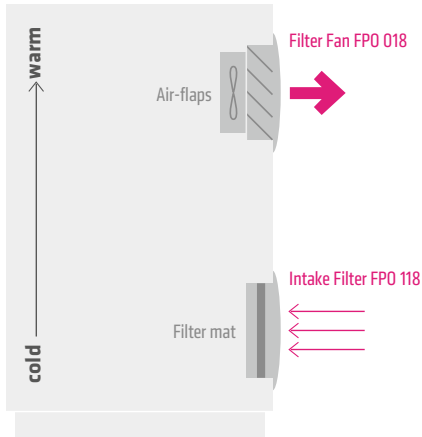

AIRFLOW DIRECTION "OUT": FILTER FAN FPO 018

Art. No.	Operating voltage	Air volume, free flow	Air volume with intake filter	Current consumption (50/60 Hz)	Power consumption	Average noise level (DIN EN ISO 4871)	Depth in enclosure	Weight (approx.)	Air outlet
01880.0-00	AC 230 V, 50/60 Hz	24 m ³ /h	15 m ³ /h	70 mA	12 W	38 db (A)	72 mm	0.6 kg	air-flaps
01880.9-00	AC 115 V, 50/60 Hz	32 m ³ /h	19 m ³ /h	115 mA	12 W	41 db (A)	72 mm	0.6 kg	air-flaps

AIRFLOW DIRECTION "OUT": INTAKE FILTER FPO 118

Art. No.	Depth in enclosure	Weight (approx.)	Filter mat
11880.0-30	22 mm	0.2 kg	ISO coarse 55 % acc. to ISO 16890 (G3), initial gravimetric arrestance 57 %

FILTER MAT FM 086

Filter class	84 x 84 mm	Initial gravimetric arrestance	1 packing unit
ISO coarse 55 % acc. to ISO 16890 (G3)	Art. No. 08633.0-00	57 %	5 pieces

TECHNICAL DRAWINGS

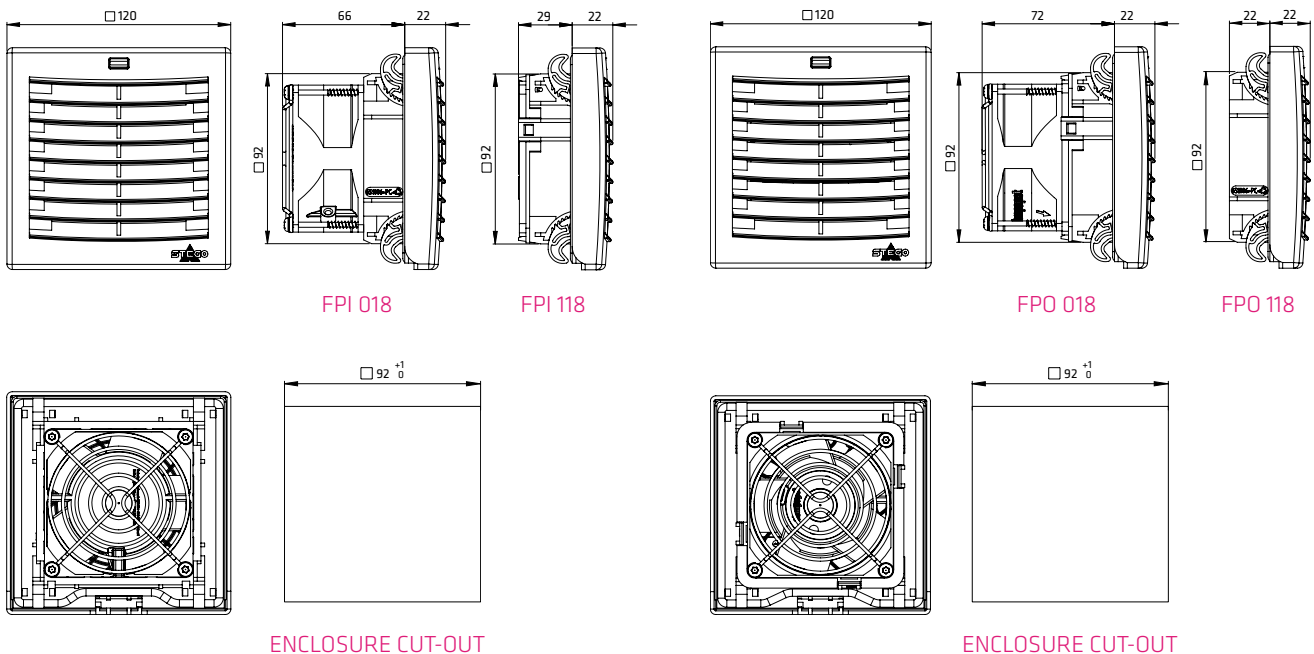

FILTER FAN PLUS

FPI/FPO 018 | up to 97 m³/h (124 x 124 mm)



- > New air-flap outlet technology for high airflow
- > Easy mounting
- > Protection type test/Environmental rating by independent testing institutes (VDE and UL)
- > Two systems for optimal airflow (FPI/FPO)
- > Standard enclosure cut-out sizes (5 sizes)
- > One filter mat

Filter fans are used to provide an optimum climate in enclosures and cabinets with electrical/electronic components. The interior temperature of an enclosure can be reduced by channelling cooler filtered outside air into the enclosure thus expelling heated internal air. The resulting airflow prevents formation of localised hot pockets in installations and protects electronic components from overheating.

The Filter Fan Plus series uses a new air-flap outlet technology for the air outlet and thus reaches a high degree of airflow. A ratchet mechanism is used for mounting and provides high stability and tightness. Depending on the application there are two systems that are available – the FPI or FPO system. The FPI system is a standard installation with a filter fan in the lower part of the enclosure which ensures that fresh air is fed into the enclosure (airflow direction "In"). This system consists of a filter fan and exit filter. Whereas in the FPO system, the filter fan is located in the upper area of the enclosure to avoid heat buildups (airflow direction "Out"). The FPO system is composed of an intake filter and exit filter fan. The Filter Fan Plus series may also be used outdoors with appropriate protective measures or when equipped with weather proof accessories, e.g. Hose-proof Hood FFH 086.

SYSTEM FPI

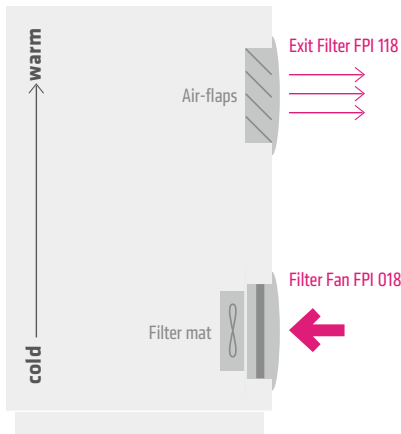

TECHNICAL DATA



Axial fan, ball bearing	service life L10 at +40 °C (+104 °F): min. 37,000 h fan body aluminium, rotor metal
Connection	2 stranded wires, 300 mm
Casing, hood, flaps	plastic according to UL94 V-0, light grey; UV light resistant according to UL746C (f1)
Enclosure cut-out	124 x 124 ¹ mm
Mounting frame	4 built-in ratchet braces for mounting (6 notches for wall thickness 1 – 4 mm). Additional use of screws possible if needed ¹ .
Filter mat	ISO coarse 55 % acc. to ISO 16890 (G3), initial gravimetric arrestance 57 %
Filter material	synthetic fibre with progressive construction, temperature resistant to +100 °C, self-extinguishing class F1, moisture resistant to 100 % RH, reusable
Operating/Storage temperature	-40 to +70 °C (-40 to +158 °F)
Operating/Storage humidity	max. 90 % RH (non-condensing)
Protection type/Protection class	IP54 / I (earthed)
Environmental rating UL/NEMA	UL TYPE 12 / NEMA 12
Approvals	VDE, UL File No. E234324, EAC
Note	other voltages on request

¹ Drilling marks for screw mounting are indicated on mounting frame.

AIRFLOW DIRECTION "IN": FILTER FAN FPI 018

Art. No.	Operating voltage	Air volume, free flow	Air volume with exit filter	Current consumption (50/60 Hz)	Power consumption	Average noise level (DIN EN ISO 4871)	Depth in enclosure	Weight (approx.)	Filter mat
01871.0-30	AC 230 V, 50/60 Hz	52 m ³ /h	42 m ³ /h	120 mA	19 W	49 db (A)	66 mm	0.8 kg	G3
01871.9-30	AC 115 V, 50/60 Hz	62 m ³ /h	51 m ³ /h	230 mA	18 W	53 db (A)	66 mm	0.8 kg	G3

AIRFLOW DIRECTION "IN": EXIT FILTER FPI 118

Art. No.	Depth in enclosure	Weight (approx.)	Air outlet
11871.0-00	35 mm	0.3 kg	air-flap outlet technology

SYSTEM FPO

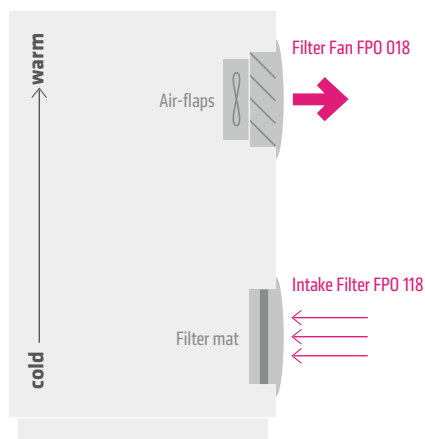

AIRFLOW DIRECTION "OUT": FILTER FAN FPO 018

Art. No.	Operating voltage	Air volume, free flow	Air volume with intake filter	Current consumption (50/60 Hz)	Power consumption	Average noise level (DIN EN ISO 4871)	Depth in enclosure	Weight (approx.)	Air outlet
01881.0-00	AC 230 V, 50/60 Hz	97 m ³ /h	47m ³ /h	120 mA	19 W	49 db (A)	79 mm	0.9 kg	air-flaps
01881.9-00	AC 115 V, 50/60 Hz	117 m ³ /h	58 m ³ /h	230 mA	18 W	52 db (A)	79 mm	0.9 kg	air-flaps

AIRFLOW DIRECTION "OUT": INTAKE FILTER FPO 118

Art. No.	Depth in enclosure	Weight (approx.)	Filter mat
11881.0-30	22 mm	0.2 kg	ISO coarse 55 % acc. to ISO 16890 (G3), initial gravimetric arrestance 57 %

FILTER MAT FM 086

Filter class	118 x 118 mm	Initial gravimetric arrestance	1 packing unit
ISO coarse 55 % acc. to ISO 16890 (G3)	Art. No. 08634.0-00	57 %	5 pieces

TECHNICAL DRAWINGS

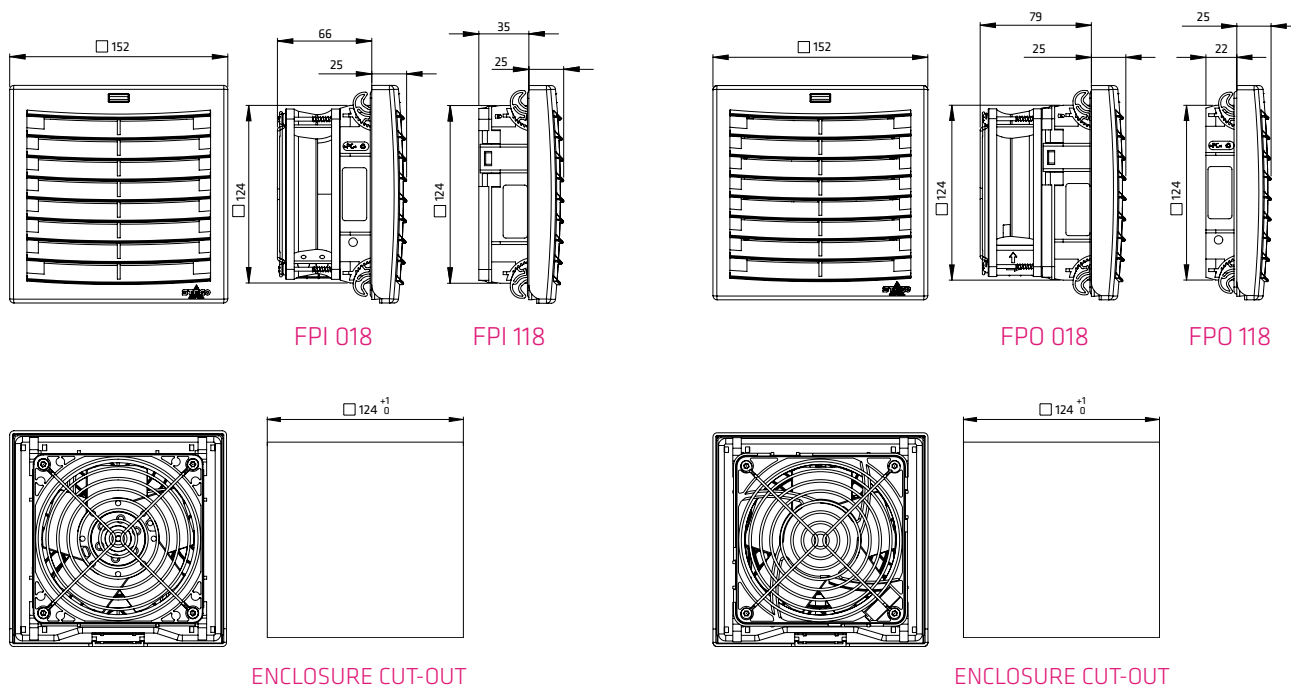

FILTER FAN PLUS

FPI/FPO 018 | up to 263 m³/h (176 x 176 mm)



- > New air-flap outlet technology for high airflow
- > Easy mounting
- > Protection type test/Environmental rating by independent testing institutes (VDE and UL)
- > Two systems for optimal airflow (FPI/FPO)
- > Standard enclosure cut-out sizes (5 sizes)
- > One filter mat

Filter fans are used to provide an optimum climate in enclosures and cabinets with electrical/electronic components. The interior temperature of an enclosure can be reduced by channelling cooler filtered outside air into the enclosure thus expelling heated internal air. The resulting airflow prevents formation of localised hot pockets in installations and protects electronic components from overheating.

The Filter Fan Plus series uses a new air-flap outlet technology for the air outlet and thus reaches a high degree of airflow. A ratchet mechanism is used for mounting and provides high stability and tightness. Depending on the application there are two systems that are available – the FPI or FPO system. The FPI system is a standard installation with a filter fan in the lower part of the enclosure which ensures that fresh air is fed into the enclosure (airflow direction "In"). This system consists of a filter fan and exit filter. Whereas in the FPO system, the filter fan is located in the upper area of the enclosure to avoid heat buildups (airflow direction "Out"). The FPO system is composed of an intake filter and exit filter fan. The Filter Fan Plus series may also be used outdoors with appropriate protective measures or when equipped with weather proof accessories, e.g. Hose-proof Hood FFH 086.

SYSTEM FPI

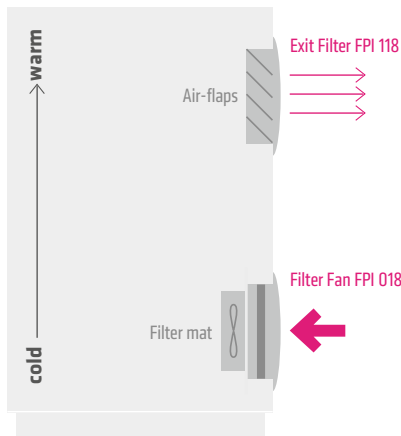

TECHNICAL DATA



Axial fan, ball bearing	service life L10 at +40 °C (+104 °F): min. 65,000 h fan body aluminium, rotor metal
Connection	3-pole clamp for 2.5 mm ² , clamping torque 0.8 Nm max.
Casing, hood, flaps	plastic according to UL94 V-0, light grey; UV light resistant according to UL746C (f1)
Enclosure cut-out	176 x 176 ¹ mm
Mounting frame	4 built-in ratchet braces for mounting (6 notches for wall thickness 1 – 4 mm). Additional use of screws possible if needed ¹ .
Filter mat	ISO coarse 55 % acc. to ISO 16890 (G3), initial gravimetric arrestance 57 %
Filter material	synthetic fibre with progressive construction, temperature resistant to +100 °C, self-extinguishing class F1, moisture resistant to 100 % RH, reusable
Operating temperature	50 Hz: -25 to +50 °C (-13 to +122 °F) 60 Hz: -25 to +70 °C (-13 to +158 °F)
Storage temperature	-40 to +70 °C (-40 to +158 °F)
Operating/Storage humidity	max. 90 % RH (non-condensing)
Protection type/Protection class	IP54 / I (earthed)
Environmental rating UL/NEMA	UL TYPE 12 / NEMA 12
Approvals	VDE, UL File No. E234324, EAC
Note	other voltages on request

¹ Drilling marks for screw mounting are indicated on mounting frame.

AIRFLOW DIRECTION "IN": FILTER FAN FPI 018

Art. No.	Operating voltage	Air volume, free flow	Air volume with exit filter	Current consumption (50/60 Hz)	Power consumption	Average noise level (DIN EN ISO 4871)	Depth in enclosure	Weight (approx.)	Filter mat
01872.0-30	AC 230 V, 50/60 Hz	170 m ³ /h	139 m ³ /h	310/250 mA	45 W	55 db (A)	117 mm	1.6 kg	G3
01872.9-30	AC 115 V, 50/60 Hz	204 m ³ /h	187 m ³ /h	560/470 mA	38 W	58 db (A)	117 mm	1.6 kg	G3

AIRFLOW DIRECTION "IN": EXIT FILTER FPI 118

Art. No.	Depth in enclosure	Weight (approx.)	Air outlet
11872.0-00	43 mm	0.4 kg	air-flap outlet technology

SYSTEM FPO

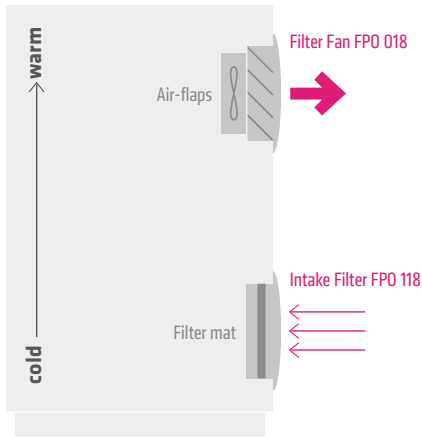

AIRFLOW DIRECTION "OUT": FILTER FAN FPO 018

Art. No.	Operating voltage	Air volume, free flow	Air volume with intake filter	Current consumption (50/60 Hz)	Power consumption	Average noise level (DIN EN ISO 4871)	Depth in enclosure	Weight (approx.)	Air outlet
01882.0-00	AC 230 V, 50/60 Hz	263 m ³ /h	137m ³ /h	310/250 mA	45 W	56 db (A)	117 mm	1.6 kg	air-flaps
01882.9-00	AC 115 V, 50/60 Hz	313 m ³ /h	166 m ³ /h	560/470 mA	38 W	60 db (A)	117 mm	1.6 kg	air-flaps

AIRFLOW DIRECTION "OUT": INTAKE FILTER FPO 118

Art. No.	Depth in enclosure	Weight (approx.)	Filter mat
11882.0-30	25 mm	0.4 kg	ISO coarse 55 % acc. to ISO 16890 (G3), initial gravimetric arrestance 57 %

FILTER MAT FM 086

Filter class	168 x 168 mm	Initial gravimetric arrestance	1 packing unit
ISO coarse 55 % acc. to ISO 16890 (G3)	Art. No. 08635.0-00	57 %	5 pieces

TECHNICAL DRAWINGS

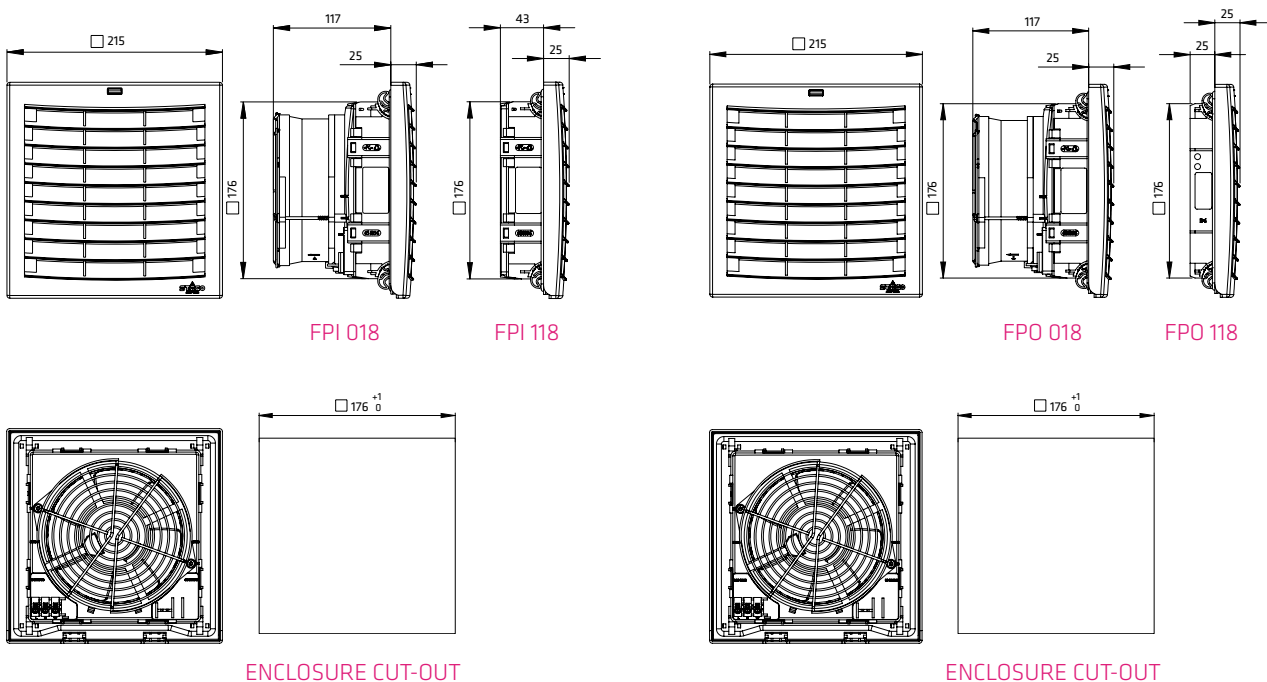

FILTER FAN PLUS

FPI/FPO 018 | up to 536 m³/h (223 x 223 mm)



- > New air-flap outlet technology for high airflow
- > Easy mounting
- > Protection type test/Environmental rating by independent testing institutes (VDE and UL)
- > Two systems for optimal airflow (FPI/FPO)
- > Standard enclosure cut-out sizes (5 sizes)
- > One filter mat

Filter fans are used to provide an optimum climate in enclosures and cabinets with electrical/electronic components. The interior temperature of an enclosure can be reduced by channelling cooler filtered outside air into the enclosure thus expelling heated internal air. The resulting airflow prevents formation of localised hot pockets in installations and protects electronic components from overheating.

The Filter Fan Plus series uses a new air-flap outlet technology for the air outlet and thus reaches a high degree of airflow. A ratchet mechanism is used for mounting and provides high stability and tightness. Depending on the application there are two systems that are available – the FPI or FPO system. The FPI system is a standard installation with a filter fan in the lower part of the enclosure which ensures that fresh air is fed into the enclosure (airflow direction "In"). This system consists of a filter fan and exit filter. Whereas in the FPO system, the filter fan is located in the upper area of the enclosure to avoid heat buildups (airflow direction "Out"). The FPO system is composed of an intake filter and exit filter fan. The Filter Fan Plus series may also be used outdoors with appropriate protective measures or when equipped with weather proof accessories, e.g. Hose-proof Hood FFH 086.

SYSTEM FPI

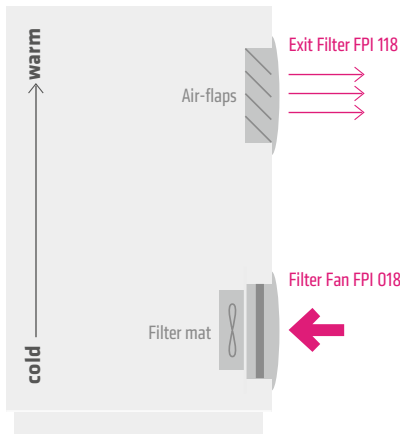

TECHNICAL DATA



Axial fan, ball bearing	service life L10 at +40 °C (+104 °F): min. 56,000 h rotor metal
Connection	3-pole clamp for 2.5 mm ² , clamping torque 0.8 Nm max.
Casing, hood, flaps	plastic according to UL94 V-0, light grey; UV light resistant according to UL746C (f1)
Enclosure cut-out	223 x 223 ¹ mm
Mounting frame	4 built-in ratchet braces for mounting (6 notches for wall thickness 1 – 4 mm). Additional use of screws possible if needed ¹ .
Filter mat	ISO coarse 55 % acc. to ISO 16890 (G3), initial gravimetric arrestance 57 %
Filter material	synthetic fibre with progressive construction, temperature resistant to +100 °C, self-extinguishing class F1, moisture resistant to 100 % RH, reusable
Operating temperature	-25 to +65 °C (-13 to +149 °F)
Storage temperature	-40 to +70 °C (-40 to +158 °F)
Operating/Storage humidity	max. 75 % RH (non-condensing)
Protection type/Protection class	IP54 / I (earthed)
Environmental rating UL/NEMA	UL TYPE 12 / NEMA 12
Approvals	VDE, UL File No. E234324, EAC
Note	other voltages on request

¹ Drilling marks for screw mounting are indicated on mounting frame.

AIRFLOW DIRECTION "IN": FILTER FAN FPI 018

Art. No.	Operating voltage	Air volume, free flow	Air volume with exit filter	Current consumption (50/60 Hz)	Power consumption	Average noise level (DIN EN ISO 4871)	Depth in enclosure	Weight (approx.)	Filter mat
01873.0-30	AC 230 V, 50/60 Hz	305 m ³ /h	271 m ³ /h	300/340 mA	64 W	64 db (A)	147 mm	2.4 kg	G3
01873.9-30	AC 115 V, 50/60 Hz	332 m ³ /h	293 m ³ /h	600/700 mA	81 W	67 db (A)	147 mm	2.4 kg	G3

AIRFLOW DIRECTION "IN": EXIT FILTER FPI 118

Art. No.	Depth in enclosure	Weight (approx.)	Air outlet
11873.0-00	46 mm	0.6 kg	air-flap outlet technology

SYSTEM FPO

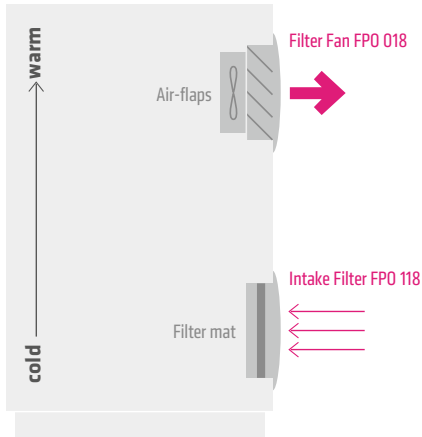

AIRFLOW DIRECTION "OUT": FILTER FAN FPO 018

Art. No.	Operating voltage	Air volume, free flow	Air volume with intake filter	Current consumption (50/60 Hz)	Power consumption	Average noise level (DIN EN ISO 4871)	Depth in enclosure	Weight (approx.)	Air outlet
01883.0-00	AC 230 V, 50/60 Hz	536 m ³ /h	281 m ³ /h	300/340 mA	64 W	65 db (A)	147 mm	2.4 kg	air-flaps
01883.9-00	AC 115 V, 50/60 Hz	581 m ³ /h	310 m ³ /h	600/700 mA	81 W	68 db (A)	147 mm	2.4 kg	air-flaps

AIRFLOW DIRECTION "OUT": INTAKE FILTER FPO 118

Art. No.	Depth in enclosure	Weight (approx.)	Filter mat
11883.0-30	25 mm	0.5 kg	ISO coarse 55 % acc. to ISO 16890 (G3), initial gravimetric arrestance 57 %

FILTER MAT FM 086

Filter class	215 x 215 mm	Initial gravimetric arrestance	1 packing unit
ISO coarse 55 % acc. to ISO 16890 (G3)	Art. No. 08636.0-00	57 %	5 pieces

TECHNICAL DRAWINGS

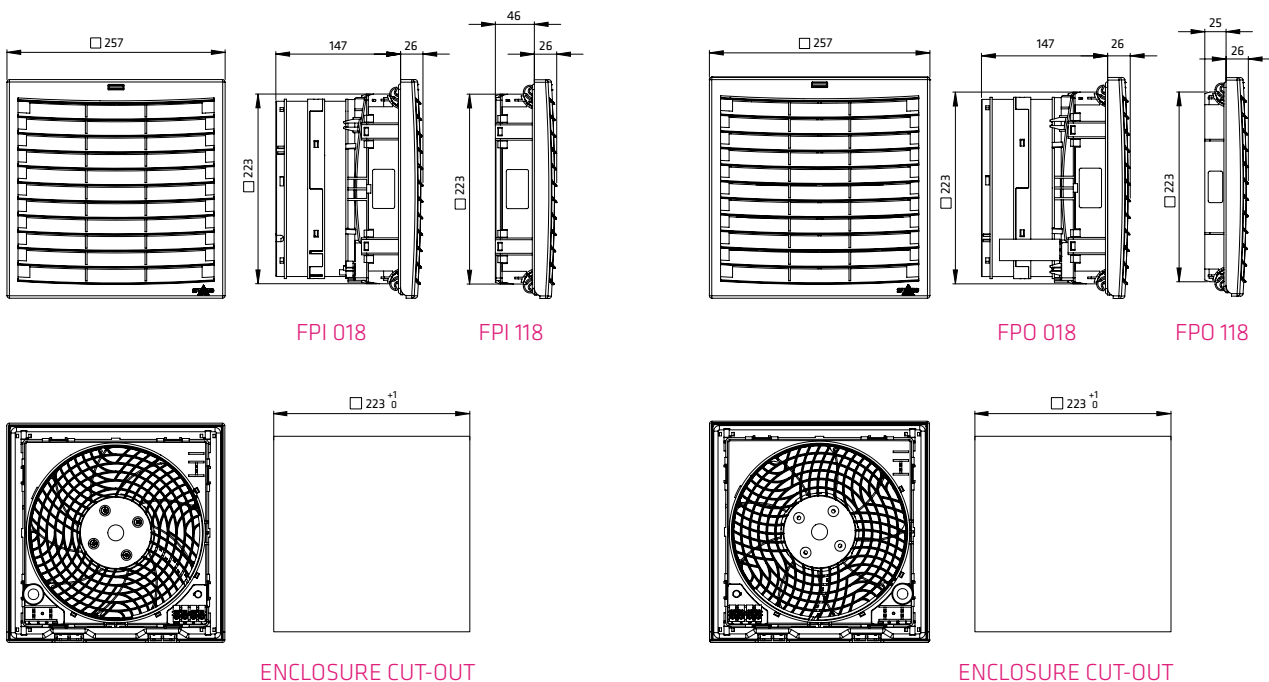

FILTER FAN PLUS

FPI/FPO 018 | up to 1010 m³/h (291 x 291 mm)



- > New air-flap outlet technology for high airflow
- > Easy mounting
- > Protection type test/Environmental rating by independent testing institutes (VDE and UL)
- > Two systems for optimal airflow (FPI/FPO)
- > Standard enclosure cut-out sizes (5 sizes)
- > One filter mat
- > Two fan speeds

Filter fans are used to provide an optimum climate in enclosures and cabinets with electrical/electronic components. The interior temperature of an enclosure can be reduced by channelling cooler filtered outside air into the enclosure thus expelling heated internal air. The resulting airflow prevents formation of localised hot pockets in installations and protects electronic components from overheating.

The Filter Fan Plus series uses a new air-flap outlet technology for the air outlet and thus reaches a high degree of airflow. A ratchet mechanism is used for mounting and provides high stability and tightness. Depending on the application there are two systems that are available – the FPI or FPO system. The FPI system is a standard installation with a filter fan in the lower part of the enclosure which ensures that fresh air is fed into the enclosure (airflow direction "In"). This system consists of a filter fan and exit filter. Whereas in the FPO system, the filter fan is located in the upper area of the enclosure to avoid heat buildups (airflow direction "Out"). The FPO system is composed of an intake filter and exit filter fan. The Filter Fan Plus series may also be used outdoors with appropriate protective measures or when equipped with weather proof accessories, e.g. Hose-proof Hood FFH 086.

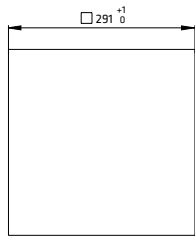

Enclosure cut-out

TECHNICAL DATA



Axial fan, ball bearing	fan speed 1: service life L10 at +40 °C (+104 °F): min. 76,000 h rotor metal fan speed 2: service life L10 at +40 °C (+104 °F): min. 54,000 h rotor plastic
Connection	3-pole clamp for 2.5 mm ² , clamping torque 0.8 Nm max.
Casing, hood, flaps	plastic according to UL94 V-0, light grey; UV light resistant according to UL746C (f1)
Enclosure cut-out	291 x 291 ¹ mm
Mounting frame	4 built-in ratchet braces for mounting (6 notches for wall thickness 1 – 4 mm). Additional use of screws possible if needed ¹ .
Filter mat	ISO coarse 55 % acc. to ISO 16890 (G3), initial gravimetric arrestance 57 %
Filter material	synthetic fibre with progressive construction, temperature resistant to +100 °C, self-extinguishing class F1, moisture resistant to 100 % RH, reusable
Operating temperature	fan speed 1 & 2, 50 Hz: -25 to +55 °C (-13 to +131 °F) fan speed 1, 60 Hz: -25 to +35 °C (-13 to +95 °F) fan speed 2, 60 Hz: -25 to +50 °C (-13 to +122 °F)
Storage temperature	-40 to +70 °C (-40 to +158 °F)
Operating/Storage humidity	max. 75 % RH (non-condensing)
Protection type/Protection class	IP54 / I (earthed)
Environmental rating UL/NEMA	UL TYPE 12 / NEMA 12
Approvals	VDE, UL File No. E234324, EAC
Note	other voltages on request

¹ Drilling marks for screw mounting are indicated on mounting frame.



SYSTEM FPI

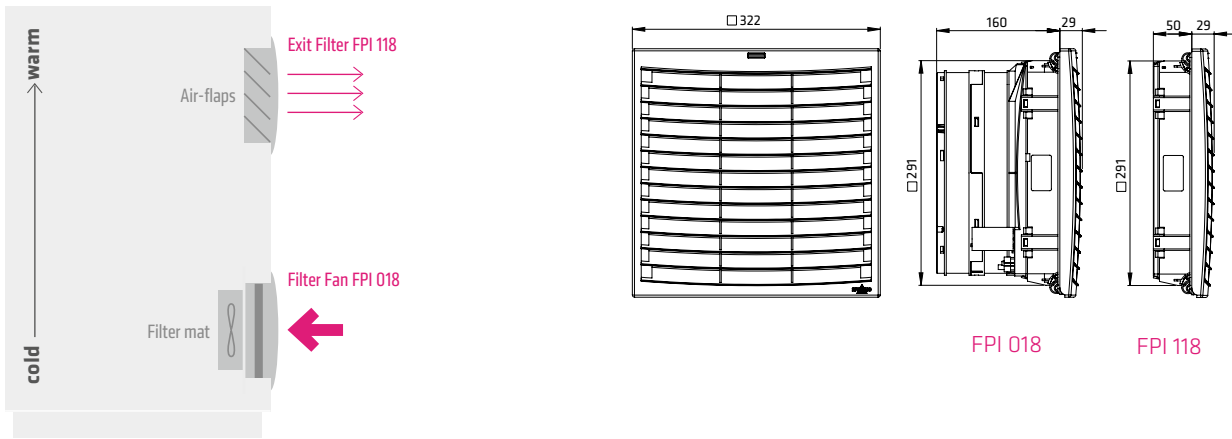

AIRFLOW DIRECTION "IN": FILTER FAN FPI 018

Art. No.	Operating voltage	Fan speed	Air volume, free flow	Air volume with exit filter	Current consumption (50/60 Hz)	Power consumption	Average noise level (DIN EN ISO 4871)	Depth in enclosure	Weight (approx.)	Filter mat
01874.0-30	AC 230 V, 50/60 Hz	1	433 m ³ /h	373 m ³ /h	400/480 mA	95 W	62 db (A)	160 mm	3.1 kg	G3
01874.0-31	AC 230 V, 50/60 Hz	2	624 m ³ /h	560 m ³ /h	550/700 mA	140 W	70 db (A)	160 mm	3.3 kg	G3
01874.9-30	AC 115 V, 50/60 Hz	1	394 m ³ /h	339 m ³ /h	660/800 mA	90 W	61 db (A)	160 mm	3.1 kg	G3
01874.9-31	AC 115 V, 50/60 Hz	2	665 m ³ /h	593 m ³ /h	1100/1450 mA	165 W	72 db (A)	160 mm	3.3 kg	G3

AIRFLOW DIRECTION "IN": EXIT FILTER FPI 118

Art. No.	Depth in enclosure	Weight (approx.)	Air outlet
11874.0-00	50 mm	1.0 kg	air-flap outlet technology

SYSTEM FPO

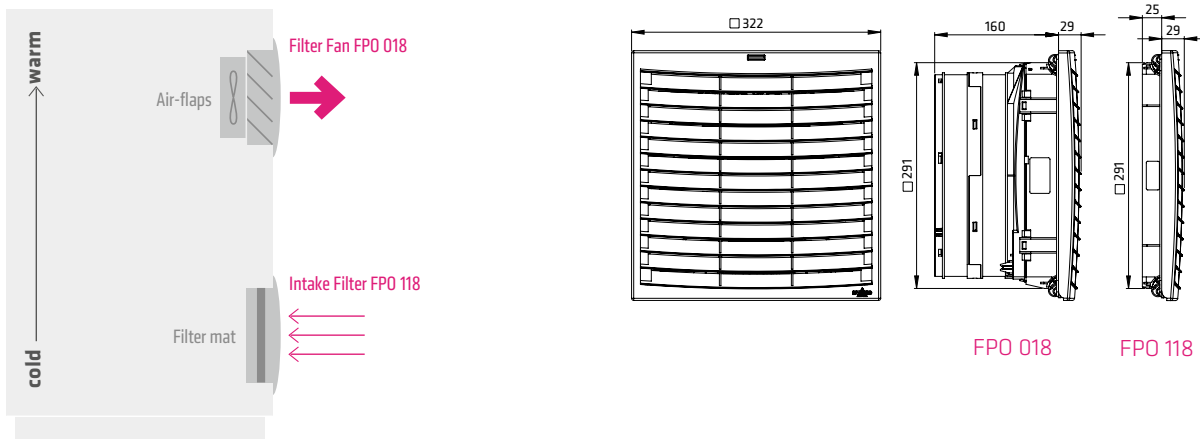

AIRFLOW DIRECTION "OUT": FILTER FAN FPO 018

Art. No.	Operating voltage	Fan speed	Air volume, free flow	Air volume with intake filter	Current consumption (50/60 Hz)	Power consumption	Average noise level (DIN EN ISO 4871)	Depth in enclosure	Weight (approx.)	Air outlet
01884.0-00	AC 230 V, 50/60 Hz	1	727 m ³ /h	413 m ³ /h	400/480 mA	95 W	63 db (A)	160 mm	3.2 kg	air-flaps
01884.0-01	AC 230 V, 50/60 Hz	2	1010 m ³ /h	599 m ³ /h	550/700 mA	140 W	70 db (A)	160 mm	3.4 kg	air-flaps
01884.9-00	AC 115 V, 50/60 Hz	1	703 m ³ /h	391 m ³ /h	660/800 mA	90 W	62 db (A)	160 mm	3.2 kg	air-flaps
01884.9-01	AC 115 V, 50/60 Hz	2	1031 m ³ /h	609 m ³ /h	1100/1450 mA	165 W	71 db (A)	160 mm	3.4 kg	air-flaps

AIRFLOW DIRECTION "OUT": INTAKE FILTER FPO 118

Art. No.	Depth in enclosure	Weight (approx.)	Filter mat
11884.0-30	25 mm	0.8 kg	ISO coarse 55 % acc. to ISO 16890 (G3), initial gravimetric arrestance 57 %

FILTER MAT FM 086

Filter class	283 x 283 mm	Initial gravimetric arrestance	1 packing unit
ISO coarse 55 % acc. to ISO 16890 (G3)	Art. No. 08637.0-00	57 %	5 pieces

FILTER FAN PLUS – DC LINE

FPI/FPO 018 | up to 33 m³/h (92 x 92 mm)



- > New air-flap outlet technology for high airflow
- > Easy mounting
- > Protection type test/Environmental rating by independent testing institutes (VDE and UL)
- > Two systems for optimal airflow (FPI/FPO)
- > Standard enclosure cut-out sizes
- > One filter mat

Filter fans are used to provide an optimum climate in enclosures and cabinets with electrical/electronic components. The interior temperature of an enclosure can be reduced by channelling cooler filtered outside air into the enclosure thus expelling heated internal air. The resulting airflow prevents formation of localised hot pockets in installations and protects electronic components from overheating.

The Filter Fan Plus series uses a new air-flap outlet technology for the air outlet and thus reaches a high degree of airflow. A ratchet mechanism is used for mounting and provides high stability and tightness. Depending on the application there are two systems that are available – the FPI or FPO system. The FPI system is a standard installation with a filter fan in the lower part of the enclosure which ensures that fresh air is fed into the enclosure (airflow direction "In"). This system consists of a filter fan and exit filter. Whereas in the FPO system, the filter fan is located in the upper area of the enclosure to avoid heat buildups (airflow direction "Out"). The FPO system is composed of an intake filter and exit filter fan. The Filter Fan Plus series may also be used outdoors with appropriate protective measures or when equipped with weather proof accessories, e.g. Hose-proof Hood FFH 086.

SYSTEM FPI

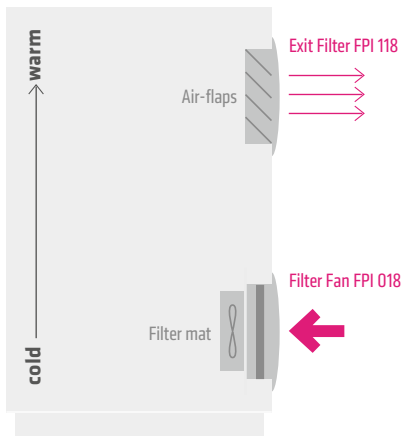

TECHNICAL DATA



Axial fan, ball bearing	service life L10 at +40 °C (+104 °F): min. 70,000 h plastic
Connection	2 stranded wires, 300 mm
Casing, hood, flaps	plastic according to UL94 V-0, light grey; UV light resistant according to UL746C (f1)
Enclosure cut-out	92 x 92 ¹ mm
Mounting frame	4 built-in ratchet braces for mounting (6 notches for wall thickness 1 – 4 mm). Additional use of screws possible if needed ¹ .
Filter mat	ISO coarse 55 % acc. to ISO 16890 (G3), initial gravimetric arrestance 57 %
Filter material	synthetic fibre with progressive construction, temperature resistant to +100 °C, self-extinguishing class F1, moisture resistant to 100 % RH, reusable
Operating temperature	-20 to +70 °C (-4 to +158 °F)
Storage temperature	-40 to +70 °C (-40 to +158 °F)
Operating/Storage humidity	max. 90 % RH (non-condensing)
Protection type/Protection class	IP54 / II (double insulated)
Environmental rating UL/NEMA	UL TYPE 12 / NEMA 12
Approvals	VDE, UL File No. E234324, EAC
Note	other voltages on request

¹ Drilling marks for screw mounting are indicated on mounting frame.

AIRFLOW DIRECTION "IN": FILTER FAN FPI 018

Art. No.	Operating voltage	Air volume, free flow	Air volume with exit filter	Current consumption	Power consumption	Average noise level (DIN EN ISO 4871)	Depth in enclosure	Weight (approx.)	Filter mat
01870.2-30	DC 24 V	22 m ³ /h	16 m ³ /h	113 mA	2.7 W	49 dB (A)	59 mm	0.3 kg	G3
01870.1-30	DC 48 V	23 m ³ /h	17 m ³ /h	63 mA	3.0 W	51 dB (A)	59 mm	0.3 kg	G3

AIRFLOW DIRECTION "IN": EXIT FILTER FPI 118

Art. No.	Depth in enclosure	Weight (approx.)	Air outlet
11870.0-00	29 mm	0.2 kg	air-flap outlet technology

SYSTEM FPO

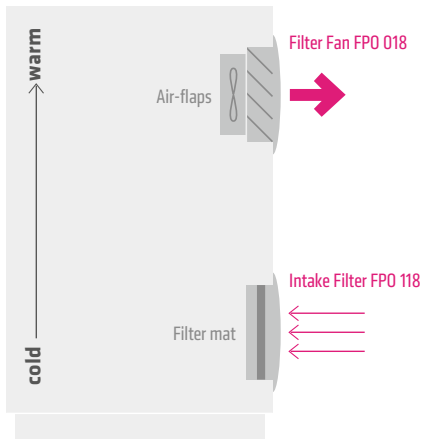

AIRFLOW DIRECTION "OUT": FILTER FAN FPO 018

Art. No.	Operating voltage	Air volume, free flow	Air volume with intake filter	Current consumption	Power consumption	Average noise level (DIN EN ISO 4871)	Depth in enclosure	Weight (approx.)	Air outlet
01880.2-00	DC 24 V	31 m ³ /h	17 m ³ /h	113 mA	2.7 W	48 dB (A)	66 mm	0.3 kg	air-flaps
01880.1-00	DC 48 V	33 m ³ /h	18 m ³ /h	63 mA	3.0 W	49 dB (A)	66 mm	0.3 kg	air-flaps

AIRFLOW DIRECTION "OUT": INTAKE FILTER FPO 118

Art. No.	Depth in enclosure	Weight (approx.)	Filter mat
11880.0-30	22 mm	0.2 kg	ISO coarse 55 % acc. to ISO 16890 (G3), initial gravimetric arrestance 57 %

FILTER MAT FM 086

Filter class	84 x 84 mm	Initial gravimetric arrestance	1 packing unit
ISO coarse 55 % acc. to ISO 16890 (G3)	Art. No. 08633.0-00	57 %	5 pieces

TECHNICAL DRAWINGS

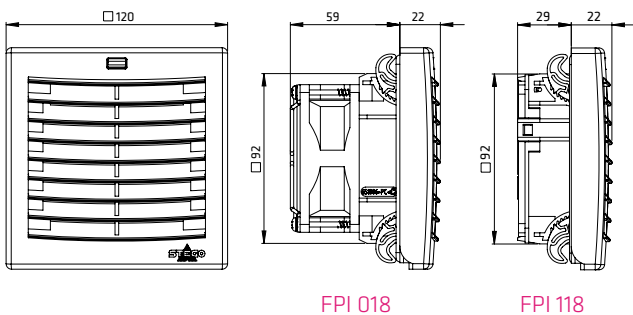

FPI 018

FPI 118

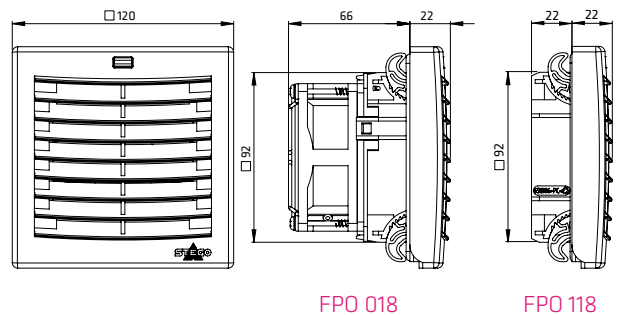

FPO 018

FPO 118

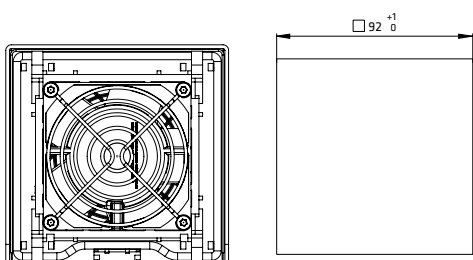

ENCLOSURE CUT-OUT

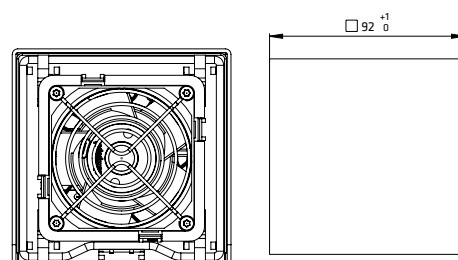

ENCLOSURE CUT-OUT

FILTER FAN PLUS – DC LINE

FPI/FPO 018 | up to 125 m³/h (124 x 124 mm)



- > New air-flap outlet technology for high airflow
- > Easy mounting
- > Protection type test/Environmental rating by independent testing institutes (VDE and UL)
- > Two systems for optimal airflow (FPI/FPO)
- > Standard enclosure cut-out sizes
- > One filter mat

Filter fans are used to provide an optimum climate in enclosures and cabinets with electrical/electronic components. The interior temperature of an enclosure can be reduced by channelling cooler filtered outside air into the enclosure thus expelling heated internal air. The resulting airflow prevents formation of localised hot pockets in installations and protects electronic components from overheating.

The Filter Fan Plus series uses a new air-flap outlet technology for the air outlet and thus reaches a high degree of airflow. A ratchet mechanism is used for mounting and provides high stability and tightness. Depending on the application there are two systems that are available – the FPI or FPO system. The FPI system is a standard installation with a filter fan in the lower part of the enclosure which ensures that fresh air is fed into the enclosure (airflow direction "In"). This system consists of a filter fan and exit filter. Whereas in the FPO system, the filter fan is located in the upper area of the enclosure to avoid heat buildups (airflow direction "Out"). The FPO system is composed of an intake filter and exit filter fan. The Filter Fan Plus series may also be used outdoors with appropriate protective measures or when equipped with weather proof accessories, e.g. Hose-proof Hood FFH 086.

SYSTEM FPI

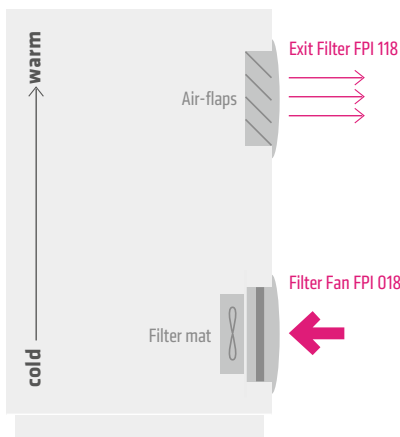

TECHNICAL DATA



Axial fan, ball bearing	service life L10 at +40 °C (+104 °F): min. 65,000 h plastic
Connection	2 stranded wires, 300 mm
Casing, hood, flaps	plastic according to UL94 V-0, light grey; UV light resistant according to UL746C (f1)
Enclosure cut-out	124 x 124 ¹ mm
Mounting frame	4 built-in ratchet braces for mounting (6 notches for wall thickness 1 – 4 mm). Additional use of screws possible if needed ¹ .
Filter mat	ISO coarse 55 % acc. to ISO 16890 (G3), initial gravimetric arrestance 57 %
Filter material	synthetic fibre with progressive construction, temperature resistant to +100 °C, self-extinguishing class F1, moisture resistant to 100 % RH, reusable
Operating temperature	-20 to +70 °C (-4 to +158 °F)
Storage temperature	-40 to +70 °C (-40 to +158 °F)
Operating/Storage humidity	max. 90 % RH (non-condensing)
Protection type/Protection class	IP54 / II (double insulated)
Environmental rating UL/NEMA	UL TYPE 12 / NEMA 12
Approvals	VDE, UL File No. E234324, EAC
Note	other voltages on request

¹ Drilling marks for screw mounting are indicated on mounting frame.

AIRFLOW DIRECTION "IN": FILTER FAN FPI 018

Art. No.	Operating voltage	Air volume, free flow	Air volume with exit filter	Current consumption	Power consumption	Average noise level (DIN EN ISO 4871)	Depth in enclosure	Weight (approx.)	Filter mat
01871.2-30	DC 24 V	66 m ³ /h	56 m ³ /h	171 mA	4.1 W	58 dB (A)	66 mm	0.5 kg	G3
01871.1-30	DC 48 V	67 m ³ /h	56 m ³ /h	88 mA	4.2 W	52 dB (A)	66 mm	0.5 kg	G3

AIRFLOW DIRECTION "IN": EXIT FILTER FPI 118

Art. No.	Depth in enclosure	Weight (approx.)	Air outlet
11871.0-00	35 mm	0.3 kg	air-flap outlet technology

SYSTEM FPO

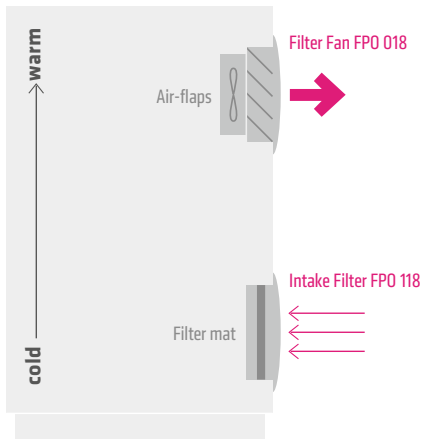

AIRFLOW DIRECTION "OUT": FILTER FAN FPO 018

Art. No.	Operating voltage	Air volume, free flow	Air volume with intake filter	Current consumption	Power consumption	Average noise level (DIN EN ISO 4871)	Depth in enclosure	Weight (approx.)	Air outlet
01881.2-00	DC 24 V	118 m ³ /h	63 m ³ /h	171 mA	4.1 W	56 dB (A)	79 mm	0.5 kg	air-flaps
01881.1-00	DC 48 V	125 m ³ /h	63 m ³ /h	88 mA	4.2 W	50 dB (A)	79 mm	0.5 kg	air-flaps

AIRFLOW DIRECTION "OUT": INTAKE FILTER FPO 118

Art. No.	Depth in enclosure	Weight (approx.)	Filter mat
11881.0-30	22 mm	0.2 kg	ISO coarse 55 % acc. to ISO 16890 (G3), initial gravimetric arrestance 57 %

FILTER MAT FM 086

Filter class	118 x 118 mm	Initial gravimetric arrestance	1 packing unit
ISO coarse 55 % acc. to ISO 16890 (G3)	Art. No. 08634.0-00	57 %	5 pieces

TECHNICAL DRAWINGS

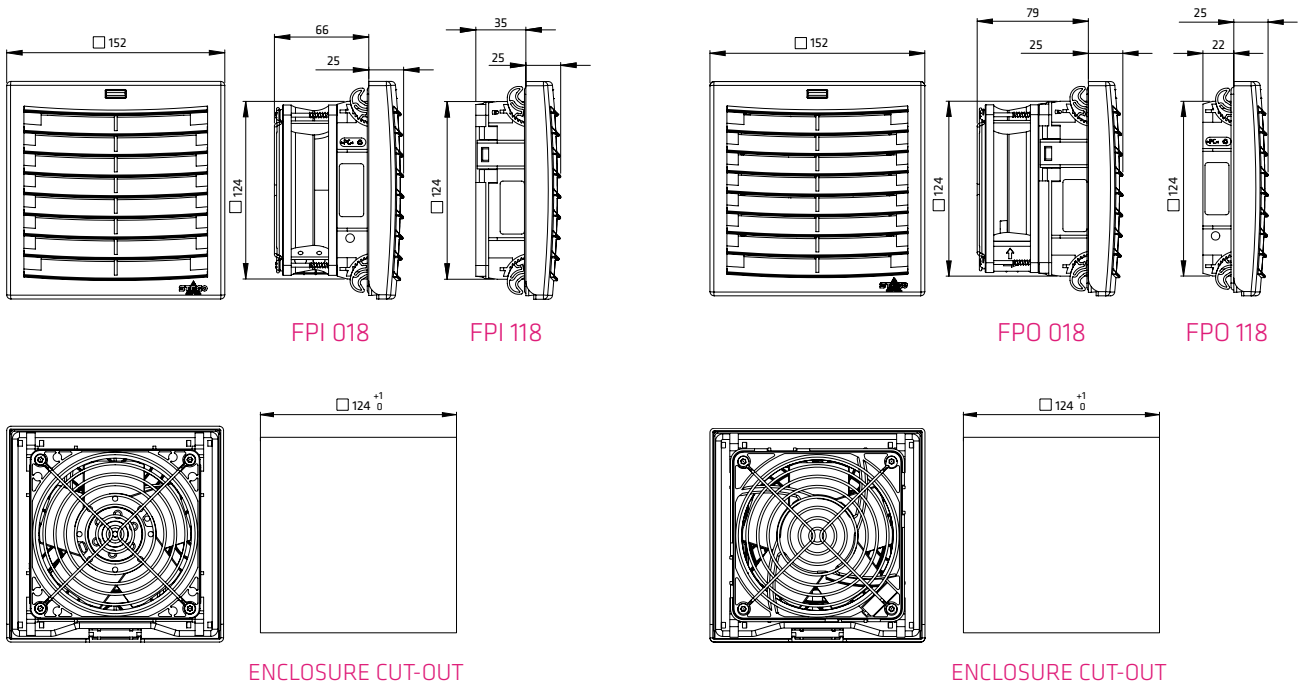

FILTER FAN PLUS – DC LINE

FPI/FPO 018 | up to 277 m³/h (176 x 176 mm)



- > New air-flap outlet technology for high airflow
- > Easy mounting
- > Protection type test/Environmental rating by independent testing institutes (VDE and UL)
- > Two systems for optimal airflow (FPI/FPO)
- > Standard enclosure cut-out sizes
- > One filter mat

Filter fans are used to provide an optimum climate in enclosures and cabinets with electrical/electronic components. The interior temperature of an enclosure can be reduced by channelling cooler filtered outside air into the enclosure thus expelling heated internal air. The resulting airflow prevents formation of localised hot pockets in installations and protects electronic components from overheating.

The Filter Fan Plus series uses a new air-flap outlet technology for the air outlet and thus reaches a high degree of airflow. A ratchet mechanism is used for mounting and provides high stability and tightness. Depending on the application there are two systems that are available – the FPI or FPO system. The FPI system is a standard installation with a filter fan in the lower part of the enclosure which ensures that fresh air is fed into the enclosure (airflow direction "In"). This system consists of a filter fan and exit filter. Whereas in the FPO system, the filter fan is located in the upper area of the enclosure to avoid heat buildups (airflow direction "Out"). The FPO system is composed of an intake filter and exit filter fan. The Filter Fan Plus series may also be used outdoors with appropriate protective measures or when equipped with weather proof accessories, e.g. Hose-proof Hood FFH 086.

SYSTEM FPI

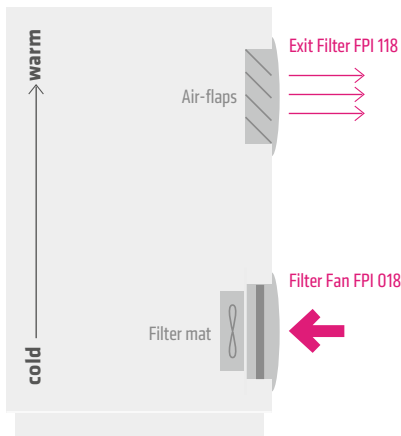

TECHNICAL DATA



Axial fan, ball bearing	service life L10 at +40 °C (+104 °F): min. 80,000 h fan body aluminium, rotor plastic
Connection	3-pole clamp for 2.5 mm ² , clamping torque 0.8 Nm max.
Casing, hood, flaps	plastic according to UL94 V-0, light grey; UV light resistant according to UL746C (f1)
Enclosure cut-out	176 x 176 ⁻¹ mm
Mounting frame	4 built-in ratchet braces for mounting (6 notches for wall thickness 1 – 4 mm). Additional use of screws possible if needed ¹ .
Filter mat	ISO coarse 55 % acc. to ISO 16890 (G3), initial gravimetric arrestance 57 %
Filter material	synthetic fibre with progressive construction, temperature resistant to +100 °C, self-extinguishing class F1, moisture resistant to 100 % RH, reusable
Operating temperature	-25 to +70 °C (-13 to +158 °F)
Storage temperature	-40 to +70 °C (-40 to +158 °F)
Operating/Storage humidity	max. 90 % RH (non-condensing)
Protection type/Protection class	IP54 / I (earthed)
Environmental rating UL/NEMA	UL TYPE 12 / NEMA 12
Approvals	VDE, UL File No. E234324, EAC
Note	other voltages on request

¹ Drilling marks for screw mounting are indicated on mounting frame.

AIRFLOW DIRECTION "IN": FILTER FAN FPI 018

Art. No.	Operating voltage	Air volume, free flow	Air volume with exit filter	Current consumption	Power consumption	Average noise level (DIN EN ISO 4871)	Depth in enclosure	Weight (approx.)	Filter mat
01872.2-30	DC 24 V	178 m ³ /h	156 m ³ /h	500 mA	12.0 W	63 dB (A)	117 mm	1.5 kg	G3
01872.1-30	DC 48 V	170 m ³ /h	147 m ³ /h	250 mA	12.0 W	63 dB (A)	117 mm	1.5 kg	G3

AIRFLOW DIRECTION "IN": EXIT FILTER FPI 118

Art. No.	Depth in enclosure	Weight (approx.)	Air outlet
11872.0-00	43 mm	0.4 kg	air-flap outlet technology

SYSTEM FPO

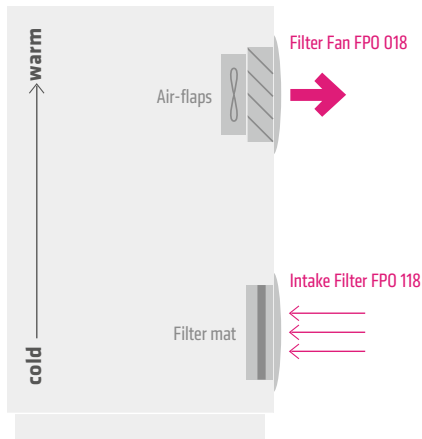

AIRFLOW DIRECTION "OUT": FILTER FAN FPO 018

Art. No.	Operating voltage	Air volume, free flow	Air volume with intake filter	Current consumption	Power consumption	Average noise level (DIN EN ISO 4871)	Depth in enclosure	Weight (approx.)	Air outlet
01882.2-00	DC 24 V	269 m ³ /h	141 m ³ /h	500 mA	12.0 W	63 dB (A)	117 mm	1.5 kg	air-flaps
01882.1-00	DC 48 V	277 m ³ /h	146 m ³ /h	250 mA	12.0 W	63 dB (A)	117 mm	1.5 kg	air-flaps

AIRFLOW DIRECTION "OUT": INTAKE FILTER FPO 118

Art. No.	Depth in enclosure	Weight (approx.)	Filter mat
11882.0-30	25 mm	0.4 kg	ISO coarse 55 % acc. to ISO 16890 (G3), initial gravimetric arrestance 57 %

FILTER MAT FM 086

Filter class	168 x 168 mm	Filter class	Initial gravimetric arrestance	1 packing unit
ISO coarse 55 % acc. to ISO 16890 (G3)	Art. No. 08635.0-00		57 %	5 pieces

TECHNICAL DRAWINGS

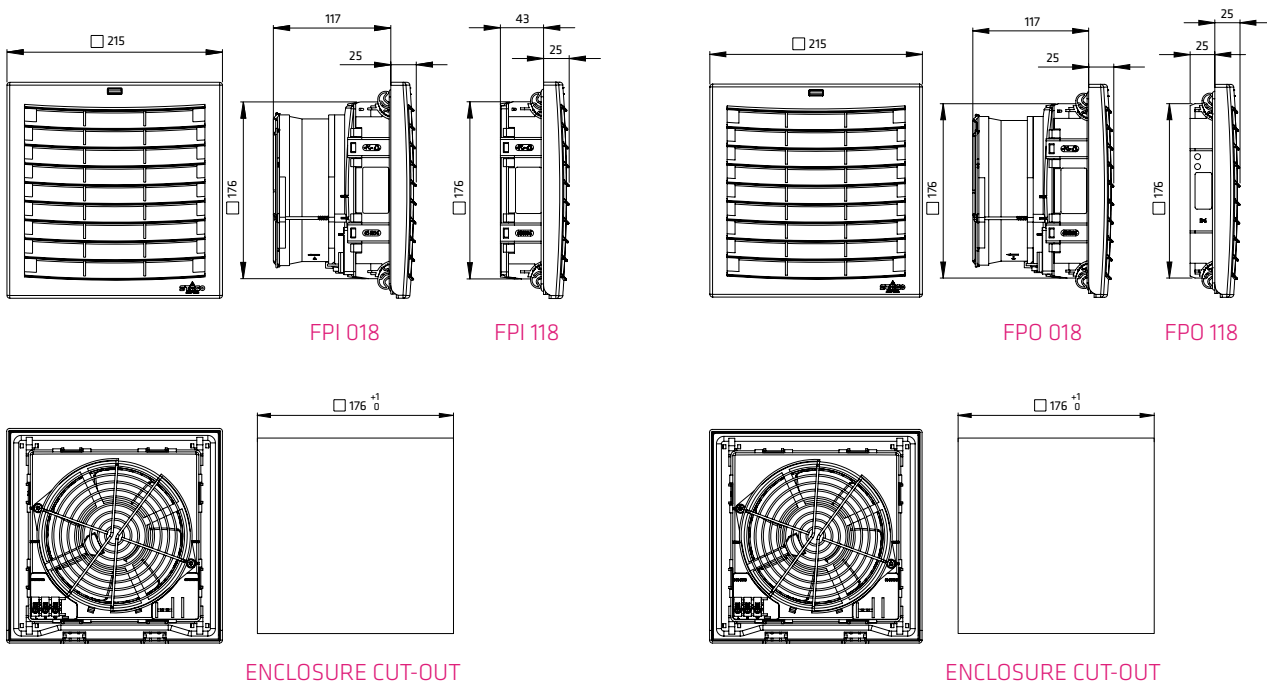

HOSE-PROOF HOOD

FFH 086 | IP56



- > Increase of protection class
- > Safe against unauthorized removal
- > Easy to clean
- > Weather resistant
- > Filter mat change from outside
- > Versatile
- > Impact-resistant, robust
- > Protective grid

The hose-proof hood for increasing the protection class is a protective cover for filter fans, intake and exit filters, e.g. for the series FPI 018, FPO 018 and FF 018. It is used for protection against water projected by a hose and extreme climatic influences if located outdoors or in industrial applications with harsh environmental conditions. In order to clean the filter fans or to change the filter mat, the hood can easily be removed, the cabinet does not need to be opened (safety risk).



TECHNICAL DATA

Material hood	VA, polished
Material sealing	Silicone, food safe
Protection type	IP56 ¹
Protection type UL/NEMA	UL Type 4/4x ¹ / Nema Type 4/4x ¹
Approval	UL File No. E234324, EAC

¹ When used with STEGO filter fans FPI/FPO 018 and FF 018 and when seal is tightly fitted.

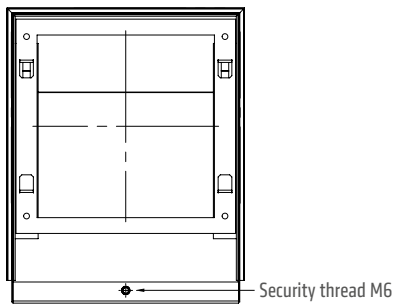
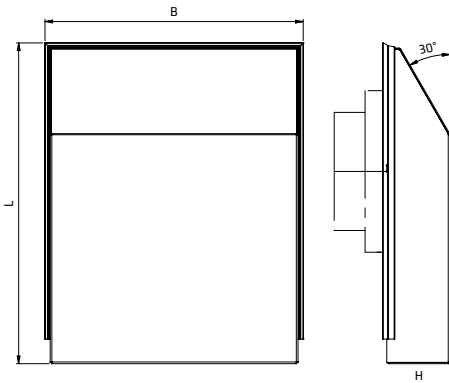

Back view

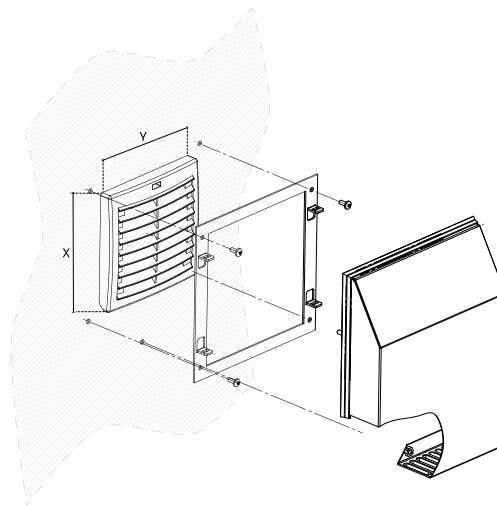

Art. No.	Cutout usable for FF 018	Cutout usable for FPI/FPO 018	Dimensions L x B x H	Max. covered area (X x Y)	Weight (approx.)
08670.0-00	97 x 97 mm	92 x 92 mm	214 x 195 x 48 mm	143 x 130 mm	0.8 kg
08671.0-00	125 x 125 mm	124 x 124 mm	279 x 225 x 58 mm	173 x 160 mm	1.2 kg
08672.0-00	176 x 176 mm	176 x 176 mm	359 x 294 x 68 mm	235 x 218 mm	2.0 kg
08673.0-00	250 x 250 mm	223 x 223 mm	415 x 369 x 78 mm	290 x 286 mm	2.8 kg
08674.0-00	-	291 x 291 mm	485 x 409 x 103 mm	340 x 326 mm	3.7 kg

ROOF FILTER FAN

RFP 018 | 300 m³/h, 500 m³/h



Photo: Art. No. 01860.0-00



Photo: Art. No. 01861.0-00

- > Very low noise
- > High reliability
- > Minimal depth in enclosure
- > Time-saving installation and mat exchange
- > High through-flow air volume

Roof filter fans find use in enclosures and housings, from which warm air has to be diverted to lower the internal temperature. These low-noise roof filter fans are used to expel warm air from within the enclosure which has been generated by the stray power of the components and so protects the internal devices from overheating. To exchange the filter mat the hood can be easily opened without tools. The roof exit filter provides passive ventilation.

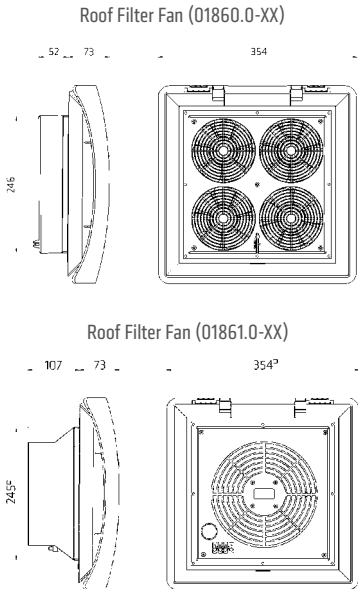

TECHNICAL DATA



Axial fans, ball bearing	service life 50,000 h at +25 °C (+77 °F), 65 % RH fan body aluminium, rotor plastic
Connection	3-pole clamp for 2.5 mm ² , clamping torque 0.8 Nm max.
Casing	plastic according to UL94 V-0, light grey; weather proof and UV light resistant according UL746C (f1)
Filter mat	ISO coarse 55 % acc. to ISO 16890 (G3), initial gravimetric arrestance 57 %
Filter material	synthetic fibre with progressive construction, temperature resistant to +100 °C, self-extinguishing class F1, moisture resistant to 100 % RH, reusable – cleaning by washing or vacuuming
Operating/Storage humidity	max. 90 % RH (non-condensing)
Protection type/Protection class	IP32 / I (earthed)
Approvals	EAC, VDE (AC 230 V only)

Important note: For reasons of pressure compensation the roof filter fan must always be operated in combination with a passive intake filter (e.g. Art. No. 11803.0-00) or another filter fan (e.g. Art. No. 01803.0-00).

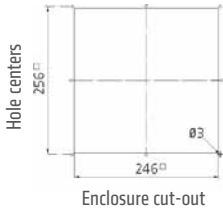

ROOF FILTER FAN RFP 018

Art. No.	Operating voltage	Air volume, free flow	Power consumption	Average noise level (DIN EN ISO 4871)	Depth in enclosure	Enclosure cut-out	Weight (approx.)	Operating / Storage temperature
01860.0-00	AC 230 V, 50 Hz	300 m ³ /h	68 W	55 dB (A)	52 mm	246 x 246 mm + 0.4	3.3 kg	-10 to +70 °C (+14 to +158 °F) / -40 to +70 °C (-40 to +158 °F)
01861.0-00	AC 230 V, 50 Hz	500 m ³ /h	64 W	67 dB (A)	107 mm	246 x 246 mm + 0.4	2.6 kg	-25 to +70 °C (-13 to +158 °F)
01860.0-02	AC 120 V, 60 Hz	345 m ³ /h	60 W	55 dB (A)	52 mm	246 x 246 mm + 0.4	3.3 kg	-10 to +70 °C (+14 to +158 °F) / -40 to +70 °C (-40 to +158 °F)
01861.0-02	AC 120 V, 60 Hz	575 m ³ /h	85 W	67 dB (A)	107 mm	246 x 246 mm + 0.4	2.6 kg	-25 to +70 °C (-13 to +158 °F)

ROOF EXIT FILTER REP 118

Art. No.	Depth in enclosure	Enclosure cut-out	Weight (approx.)	Filter mat	Protection type
11860.0-00	11 mm	246 x 246 mm + 0.4	1.0 kg	ISO coarse 55 % acc. to ISO 16890 (G3), initial gravimetric arrestance 57 %	IP32

FILTER MAT FM 086

Filter mat	282 x 282 mm
G3 (1 packing unit = 3 pcs.)	Art. No. 08613.0-01

HIGH-PERFORMANCE 19" FAN TRAY

LE 019



- > High air output
- > Long service life
- > Ball bearing fans
- > Ready for connection
- > Optical function indicator

Compact high performance fan tray for enforced circulation of air in switch and server enclosures and for concerted cooling of 19" component groups. Natural convection is improved and the formation of localised hot pockets is avoided. Also available with integrated thermostat (see photo).

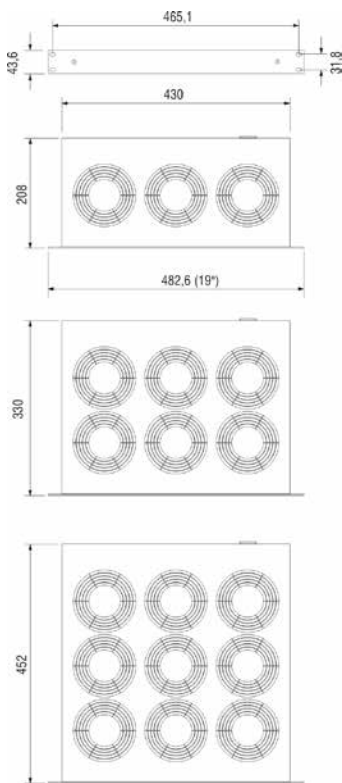

TECHNICAL DATA

Axial fans, ball bearing	service life 50,000 h at +25 °C (+77 °F), 65 % RH
Material	front panel aluminium, bright anodised casing steel sheet, electrogalvanized
Optical indicator	integrated in front panel
Connection	appliance power inlet on rear of casing, plug included
Fitting position	vertical airflow (air outlet up)
Operating/Storage temperature	-10 to +60 °C (+14 to +140 °F) / -40 to +70 °C (-40 to +158 °F)
Operating/Storage humidity	max. 90 % RH (non-condensing)
Protection type/Protection class	IP20 / I (earthed)

Use in 19" enclosures: We recommend using the fan tray without integrated thermostat in combination with our dual thermostat (ZR 011 Art. No. 01176.0-00) for regulating temperature in electronic enclosures and for protection against over-heating due to possible fan failure. The dual thermostat regulates the operation of the fan tray and – when connected to a signal device – also triggers an early warning if the enclosure interior temperature rises above a set limit. When using a fan tray with integrated thermostat, the use of an additional thermostat (KTS 011 Art. No. 01147.9-00) provides the extra safety of activating a signal device.

Art. No.	Thermostat	No. of fans	Operating voltage	Air volume, free flow	Power consumption	Average noise level (DIN EN ISO 4871)	Speed (rpm)	Weight (approx.)	Approvals	
01930.0-00	without	3	AC 230 V, 50 Hz	486 m ³ /h	45 W	55 db (A)	2,600 rpm (50 Hz)	3.0 kg	UL File No. E234324	EAC
01930.1-00	0 to +60 °C	3	AC 230 V, 50 Hz	486 m ³ /h	45 W	55 db (A)	2,600 rpm (50 Hz)	3.4 kg	UL File No. E234324	EAC
01940.0-00	without	6	AC 230 V, 50 Hz	972 m ³ /h	90 W	57 db (A)	2,600 rpm (50 Hz)	5.3 kg	UL File No. E234324	EAC
01940.1-00	0 to +60 °C	6	AC 230 V, 50 Hz	972 m ³ /h	90 W	57 db (A)	2,600 rpm (50 Hz)	5.7 kg	UL File No. E234324	EAC
01950.0-00	without	9	AC 230 V, 50 Hz	1,458 m ³ /h	135 W	58 db (A)	2,600 rpm (50 Hz)	7.8 kg	UL File No. E234324	EAC
01950.1-00	0 to +60 °C	9	AC 230 V, 50 Hz	1,458 m ³ /h	135 W	58 db (A)	2,600 rpm (50 Hz)	7.9 kg	-	EAC
01931.0-00	without	3	AC 120 V, 60 Hz	576 m ³ /h	45 W	55 db (A)	2,900 rpm (60 Hz)	3.0 kg	UL File No. E234324	EAC
01931.1-00	0 to +60 °C	3	AC 120 V, 60 Hz	576 m ³ /h	45 W	55 db (A)	2,900 rpm (60 Hz)	3.4 kg	UL File No. E234324	EAC
01941.0-00	without	6	AC 120 V, 60 Hz	1,152 m ³ /h	90 W	57 db (A)	2,900 rpm (60 Hz)	5.3 kg	UL File No. E234324	EAC
01941.1-00	0 to +60 °C	6	AC 120 V, 60 Hz	1,152 m ³ /h	90 W	57 db (A)	2,900 rpm (60 Hz)	5.7 kg	-	EAC
01951.0-00	without	9	AC 120 V, 60 Hz	1,728 m ³ /h	135 W	58 db (A)	2,900 rpm (60 Hz)	7.8 kg	UL File No. E234324	EAC
01951.1-00	0 to +60 °C	9	AC 120 V, 60 Hz	1,728 m ³ /h	135 W	58 db (A)	2,900 rpm (60 Hz)	7.9 kg	-	EAC

STEGOJET

SJ 019



- > Prevents heat pockets
- > Wide voltage range
- > Compact design
- > Quick connection
- > Clip or screw fixing

The STEGOJET is a compact, powerful built-in-fan. It allows precise cooling of heat sources and the air flow prevents formation of heat pockets. Its design offers a maximum rotation range with an air output in almost any direction. On one hand the dual clip system (two clips in a 90° angle) allows four different positions on a DIN rail, while on the other hand the hinge in the housing can be moved in a 40° angle. The airflow at the air outlet can also be directed in a 45° angle and the air duct can be rotated in steps of 60°.



TECHNICAL DATA

Axial fan, ball bearing	air flow 27.6 m ³ /h, free flow service life 40,000 h at +60 °C (+140 °F), 90 % RH
Power consumption	4 W
Average noise level (DIN EN ISO 4871)	44 dB (A)
Connection	2-pole dual pressure clamp for rigid wire 2.5 mm ² , stranded wire (with wire end ferrule) 1.5 mm ²
Casing	plastic according UL94 V-0, black
Mounting	clip for 35 mm DIN rail, EN 60715 or screw fixing (M5), torque 2 Nm max., washers have to be used
Fitting position	variable
Dimensions	132 x 75 x 60 mm
Weight	approx. 0.2 kg
Operating/Storage temperature	-10 to +60 °C (+14 to +140 °F)/-30 to +70 °C (-22 to +158 °F)
Operating/Storage humidity	max. 90 % RH (non-condensing)
Protection type	IP20

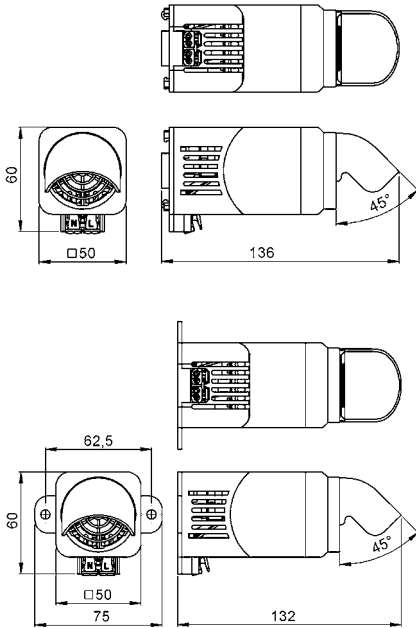

Range of rotation:

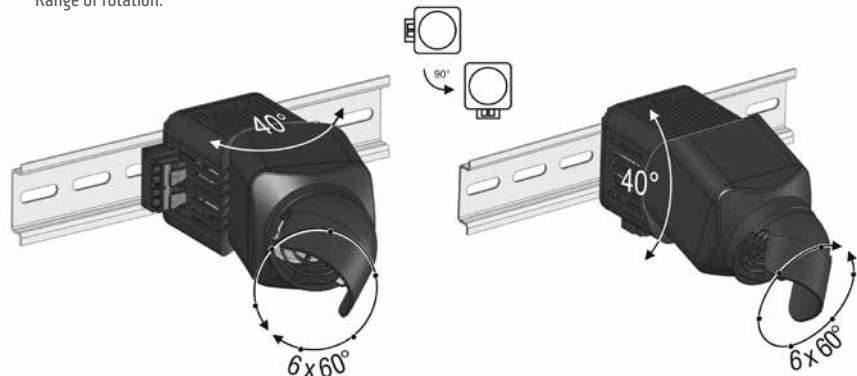

Art. No.	Model	Operating voltage	Protection class	Approvals
01925.0-00	Clip fixing	AC 100 – 240 V, 50/60 Hz (min. AC 90 V, max. AC 265 V)	II (double insulated)	VDE, UL File No. E234324, EAC
01925.0-01	Screw fixing	AC 100 – 240 V, 50/60 Hz (min. AC 90 V, max. AC 265 V)	II (double insulated)	VDE, UL File No. E234324, EAC
01925.1-00	Clip fixing	DC 24 V (min. DC 12 V, max. DC 26.4 V)	III (double insulated)	VDE, -, EAC
01925.1-01	Screw fixing	DC 24 V (min. DC 12 V, max. DC 26.4 V)	III (double insulated)	VDE, -, EAC



REGULATING/ MONITORING

CONSTANT MONITORING

STEGO's temperature and humidity control systems perfect operating conditions for electric and electronic installations and therefore safeguard their performance.

SMALL COMPACT THERMOSTAT

KTO 011 / KTS 011

- > Large setting range
- > Small size

- > Simple to mount
- > High switching performance

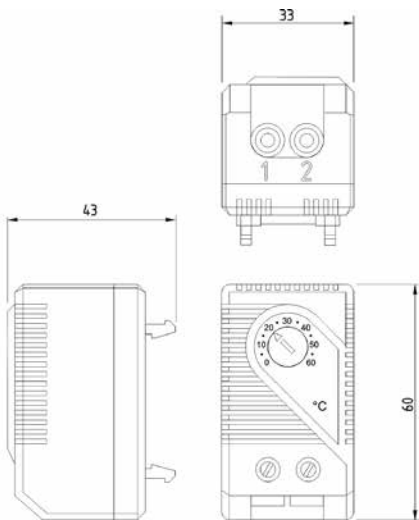

Connection diagrams

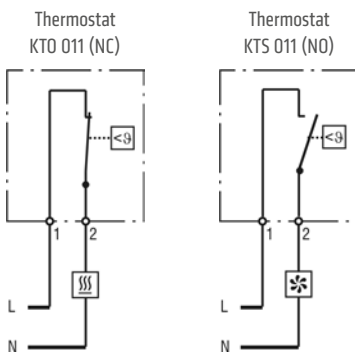

- Heater
- Filter fan, Cooling equipment, Signal device

The mechanical thermostats KTO 011 and KTS 011 are two state regulators used to control heaters, coolers, filter fans or signal devices.

KTO 011: Thermostat (NC); contact breaker for regulating heaters. The contact opens when temperature is rising.

KTS 011: Thermostat (NO); contact maker for regulating of filter fans and heat exchangers or for switching signal devices when temperature limit has been exceeded. The contact closes when temperature is rising.



TECHNICAL DATA

Switch temperature difference	7 K (±4 K tolerance)
Sensor element	thermostatic bimetal
Contact type	snap-action contact
Service life	> 100,000 cycles
Max. operating voltage	AC 250 V (VDE) AC 120 V (UL)
Max. inrush current	AC 16 A for 10 sec.
Connection	2-pole terminal, clamping torque 0.5 Nm max.: rigid wire 2.5 mm ² (AWG 14) stranded wire ¹ 1.5 mm ² (AWG 16)
Mounting	clip for 35 mm DIN rail, EN 60715
Casing	plastic according to UL94 V-0, light grey
Dimensions	60 x 33 x 43 mm
Weight	approx. 40 g
Fitting position	variable
Operating/Storage temperature	-45 to +80 °C (-49 to +176 °F)
Operating/Storage humidity	max. 90 % RH (non-condensing)
Protection type	IP20

¹ When connecting with wires, wire end ferrules must be used.

Important note: The contact system of the regulator is subjected to environmental influences, thus the contact resistance may change. This can lead to a voltage drop and/or self-heating of the contacts.

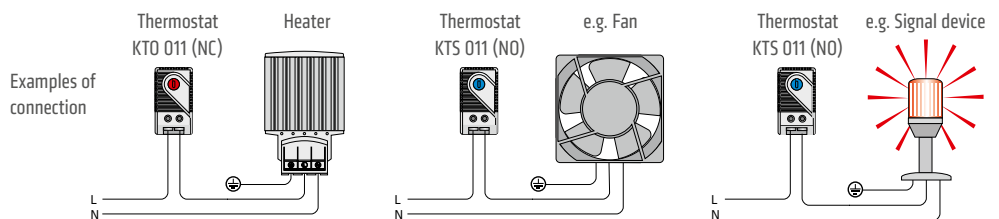

Setting range	Art. No. Contact breaker (NC)	Art. No. Contact maker (NO)	Switching current/capacity max.			Approvals		
			AC 250 V	AC 120 V	DC 24 - 72 V			
0 to +60 °C	01140.0-00	01141.0-00	10 (2) A	15 (2) A	30 W	VDE	-	EAC
-10 to +50 °C	01142.0-00	01143.0-00	10 (2) A	15 (2) A	30 W	VDE	UL File No. E164102	EAC
+20 to +80 °C	01159.0-00	01158.0-00	3 (2) A	3 (2) A	30 W	VDE	UL File No. E164102	CSA EAC
+32 to +140 °F	01140.9-00	01141.9-00	10 (2) A	15 (2) A	30 W	VDE	UL File No. E164102	CSA EAC
+14 to +122 °F	01142.9-00	01143.9-00	10 (2) A	15 (2) A	30 W	VDE	UL File No. E164102	CSA EAC
0 to +60 °C	01146.9-00	01147.9-00	10 (2) A	15 (2) A	30 W	VDE	UL File No. E164102	CSA EAC

SMALL COMPACT THERMOSTAT

STO 011 / STS 011



- > Thumbwheel setting dial
- > Small hysteresis
- > High switching capacity
- > Anti frost assurance
- > Optimized housing for better air flow

The mechanical thermostat is a two state regulator with small hysteresis. The setting wheel has an anti frost assurance. The housing ensures an optimized air circulation around the bimetal.

STO 011: Thermostat (NC); contact breaker for regulating heaters. The contact opens when temperature is rising.

STS 011: Thermostat (NO); contact maker for regulating of filter fans and heat exchangers or for switching signal devices when temperature limit has been exceeded. The contact closes when temperature is rising.

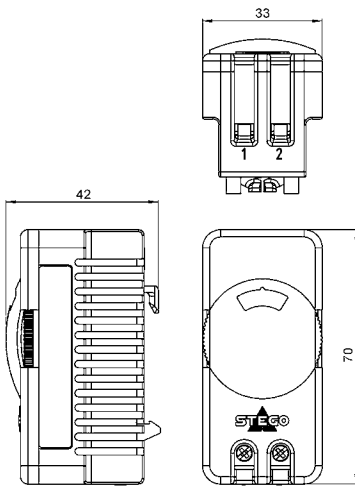

The anti frost assurance is a symbol on the setting scale of the NC thermostat (STO 011) at +11 °C. This setting assures closing of the switching contact before 0 °C.



TECHNICAL DATA

Switch temperature difference	4 K (±3 K tolerance)
Sensor element	thermostatic bimetal
Contact type	snap-action contact
Service life	> 100,000 cycles
Max. switching capacity	AC 250 V, 10 (2) A / AC 120 V, 15 (2) A DC 30 W at DC 24 V to DC 72 V
Max. inrush current	AC 16 A for 10 sec.
Connection	2-pole terminal, clamping torque 1 Nm max.: rigid/stranded ¹ wire 2.5 mm ² (AWG 14)
Mounting	clip for 35 mm DIN rail, EN 60715
Casing	plastic according to UL94V-0, light grey
Dimensions	70 x 33 x 42 mm
Weight	approx. 50 g
Fitting position	variable
Operating/Storage temperature	-45 to +80 °C (-49 to +176 °F)
Operating/Storage humidity	max. 90 % RH (non-condensing)
Protection type	IP20
Approvals	VDE, UL File No. E164102, EAC

¹ When connecting with stranded wires, wire end ferrules must be used.

Important note: The contact system of the regulator is subjected to environmental influences, thus the contact resistance may change. This can lead to a voltage drop and/or self-heating of the contacts.

Connection diagrams

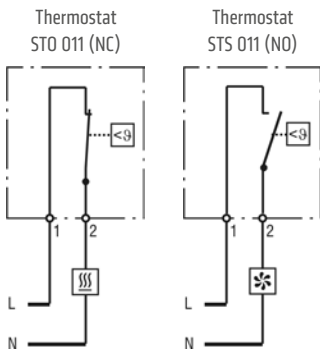

- Heater
- Filter fan, Cooling equipment, Signal device

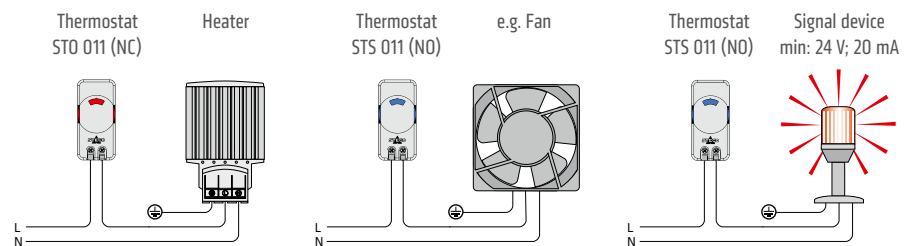

Examples of connection

Setting range	Art. No. Contact breaker (NC)	Art. No. Contact maker (NO)
0 to +60 °C	01115.0-00	01116.0-00
+32 to +140 °F	01115.9-00	01116.9-00

TAMPER-PROOF THERMOSTAT (PRE-SET)

FTO 011 / FTS 011



- > Small size
- > Default temperature settings

- > Easy to install
- > High switching accuracy

Tamper-proof (Pre-set) Thermostat FTO 011: Contact breaker/NC (red casing) for regulating heaters or for switching signal devices when temperature has fallen below the minimum value. The contact opens when temperature is rising.

Tamper-proof (Pre-set) Thermostat FTS 011: Contact maker/NO (blue casing) for regulating filter fans, heat exchangers, cooling devices or for switching signal devices when temperature limit has been exceeded. The contact closes when temperature is rising.

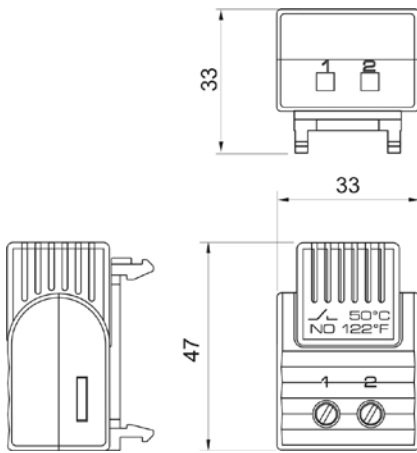

TECHNICAL DATA

Sensor element	thermostatic bimetal
Contact type	snap-action contact
Service life	> 100,000 cycles
Max. switching capacity	AC 250 V, 5 (1.6) A / AC 120 V, 10 (2) A DC 30 W
Max. inrush current	AC 16 A for 10 sec.
Connection	2-pole terminal, clamping torque 0.8 Nm max.: rigid/stranded ¹ wire 2.5 mm ² (AWG 14)
Mounting	clip for 35 mm DIN rail, EN 60715
Casing	plastic according to UL94 V-0, light grey
Dimensions	47 x 33 x 33 mm
Weight	approx. 30 g
Fitting position	variable
Operating/Storage temperature	-40 to +80 °C (-40 to +176 °F) / -45 to +80 °C (-49 to +176 °F)
Operating/Storage humidity	max. 90 % RH (non-condensing)
Protection type	IP20
Approvals	VDE, UL File No. E164102, EAC

Connection diagrams

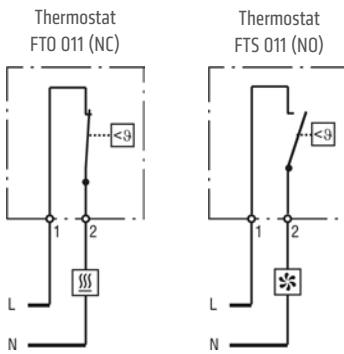

- Heater
- Filter fan, Cooling equipment, Signal device

¹ When connecting with stranded wires, wire end ferrules must be used.

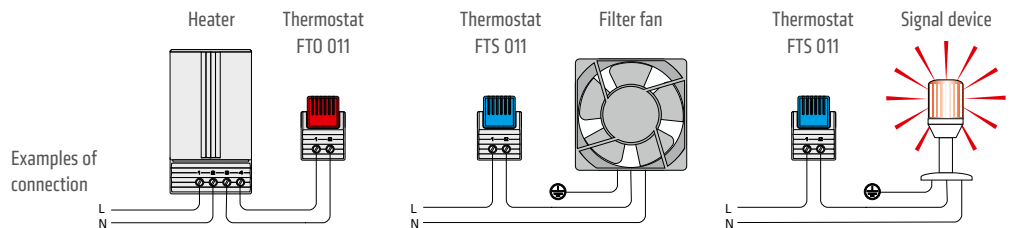

Art. No.	Contact	Switch-off temperature	Switch-on temperature
01160.0-00	Contact breaker (NC)	+15 °C / +59 °F (±5 K tolerance)	+5 °C / +41 °F (±5 K tolerance)
01160.0-01	Contact breaker (NC)	+25 °C / +77 °F (±5 K tolerance)	+15 °C / +59 °F (±5 K tolerance)
01160.0-05	Contact breaker (NC)	+10 °C / +50 °F (±5 K tolerance)	0 °C / +32 °F (±5 K tolerance)
Art. No.	Contact	Switch-on temperature	Switch-off temperature
01161.0-00	Contact maker (NO)	+50 °C / +122 °F (±7 K tolerance)	+40 °C / +104 °F (±6 K tolerance)
01161.0-01	Contact maker (NO)	+60 °C / +140 °F (±7 K tolerance)	+50 °C / +122 °F (±7 K tolerance)
01161.0-02	Contact maker (NO)	+35 °C / +95 °F (±7 K tolerance)	+25 °C / +77 °F (±6 K tolerance)

Note: Other switch-off and switch-on temperatures on request.

DUAL THERMOSTAT

ZR 011



- > NO and NC in one casing
- > Separate adjustable temperatures
- > High switching capacity
- > Terminals easily accessible
- > Clip fixing

Two thermostats in one casing:

Thermostat (contact breaker, normally closed) for regulating heaters. The contact opens when temperature is rising.
Thermostat (contact maker, normally open) for regulating filter fans and heat exchangers or switching signal devices when temperature limit has been exceeded. The contact closes when temperature is rising.

Heaters and cooling equipment can be switched independently from each other with a temperature offset as opposed to the usual change-over contacts.

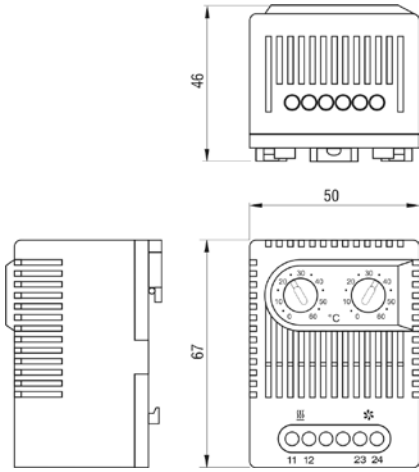

TECHNICAL DATA

Switch temperature difference	7 K (±4 K tolerance)
Sensor element	thermostatic bimetal
Contact type	snap-action contact
Service life	> 100,000 cycles
Max. switching capacity	AC 250 V, 10 (2) A AC 120 V, 15 (2) A DC 30 W at DC 24 V to DC 72 V
Max. inrush current	AC 16 A for 10 sec.
Connection	4-pole terminal, clamping torque 0.5 Nm max.: rigid wire 2.5 mm ² (AWG 14) stranded wire ¹ 1.5 mm ² (AWG 16)
Mounting	clip for 35 mm DIN rail, EN 60715
Casing	plastic according to UL94 V-0. light grey
Dimensions	67 x 50 x 46 mm
Weight	approx. 90 g
Fitting position	variable
Operating/Storage temperature	-45 to +80 °C (-49 to +176 °F)
Operating/Storage humidity	max. 90 % RH (non-condensing)
Protection type	IP20
Approvals	VDE, UL File No. E164102, CSA, EAC

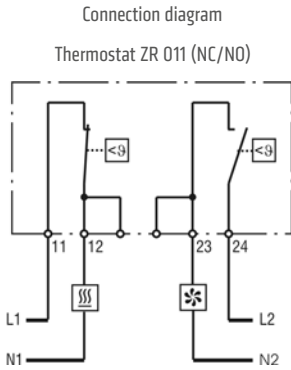

¹ When connecting with wires, wire end ferrules must be used.

Important note: The contact system of the regulator is subjected to environmental influences, thus the contact resistance may change. This can lead to a voltage drop and/or self-heating of the contacts.

- Heater
- Filter fan, Cooling equipment, Signal device

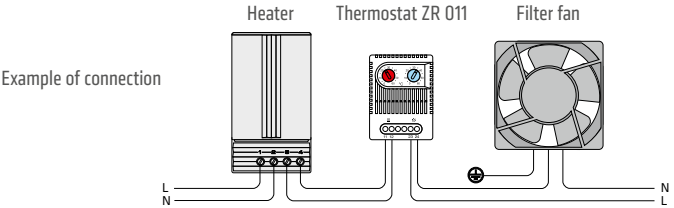

Art. No.	Setting range	Setting range
01172.0-00	Contact breaker (NC) 0 to +60 °C	Contact maker (NO) 0 to +60 °C
01172.0-01	Contact breaker (NC) +32 to +140 °F	Contact maker (NO) +32 to +140 °F
01175.0-00	Contact breaker (NC) -10 to +50 °C	Contact maker (NO) +20 to +80 °C
01175.0-01	Contact breaker (NC) +14 to +122 °F	Contact maker (NO) +68 to +176 °F
01176.0-00 ²	Contact maker (NO) 0 to +60 °C	Contact maker (NO) 0 to +60 °C
01176.0-01 ²	Contact maker (NO) +32 to +140 °F	Contact maker (NO) +32 to +140 °F

² For regulating heat exchangers and fans (e. g. LE 019) and as an alarm contact for monitoring the interior temperature of electronic enclosures.

TAMPER-PROOF DUAL THERMOSTAT (PRE-SET)

FTD 011



- > NO and NC in one casing
- > High switching accuracy
- > Default temperature settings
- > Clip fixing

Two thermostats in one casing:

Tamper-proof (Pre-set) Thermostat/Contact breaker (NC) for regulating heaters or for switching signal devices when temperature has fallen below the minimum value. The contact opens when temperature is rising.

Tamper-proof (Pre-set) Thermostat/Contact maker (NO) for regulating filter fans, heat exchangers or for switching signal devices when temperature limit has been exceeded. The contact closes when temperature is rising.

Heaters and cooling equipment can be switched independently from each other with a temperature offset as opposed to the usual change-over contacts.



TECHNICAL DATA

Sensor element	thermostatic bimetal
Contact type	snap-action contact
Service life	> 100,000 cycles
Max. switching capacity	AC 250 V, 5 (1.6) A / AC 120 V, 10 (2) A DC 30 W
Max. inrush current	AC 16 A for 10 sec.
Connection	4-pole terminal, clamping torque 0.8 Nm max.: rigid wire 2.5 mm ² (AWG 14) stranded wire ¹ 1.5 mm ² (AWG 16)
Mounting	clip for 35 mm DIN rail, EN 60715
Casing	plastic according to UL94 V-0, light grey
Dimensions	47 x 63 x 33 mm
Weight	approx. 40 g
Fitting position	variable
Operating/Storage temperature	-40 to +80 °C (-40 to +176 °F) / -45 to +80 °C (-49 to +176 °F)
Operating/Storage humidity	max. 90 % RH (non-condensing)
Protection type	IP20
Approvals	VDE, UL File No. E164102, EAC

¹ When connecting with stranded wires, wire end ferrules must be used.

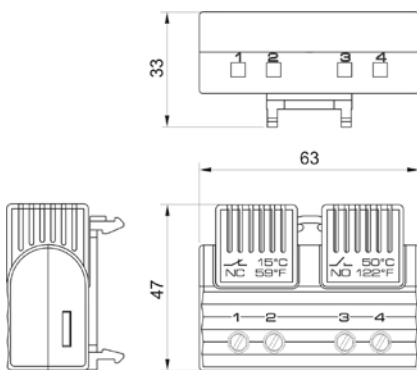

Thermostat FTD 011 (NC/NO)

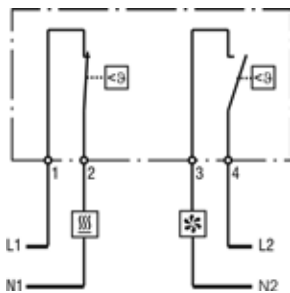

Connection diagram

- Heater
- Filter fan, Cooling equipment, Signal device

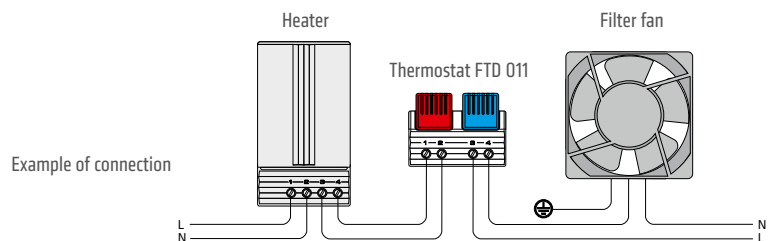

Example of connection

Art. No.	Contact breaker (NC)		Contact maker (NO)	
	Switch-off temperature	Switch-on temperature	Switch-on temperature	Switch-off temperature
01163.0-00	+15 °C / +59 °F (±5 K tolerance)	+5 °C / +41 °F (±5 K tolerance)	+50 °C / +122 °F (±7 K tolerance)	+40 °C / +104 °F (±6 K tolerance)
01163.0-01	+25 °C / +77 °F (±5 K tolerance)	+15 °C / +59 °F (±5 K tolerance)	+60 °C / +140 °F (±7 K tolerance)	+50 °C / +122 °F (±7 K tolerance)
01163.0-02	+15 °C / +59 °F (±5 K tolerance)	+5 °C / +41 °F (±5 K tolerance)	+35 °C / +95 °F (±7 K tolerance)	+25 °C / +77 °F (±6 K tolerance)
01163.0-03	+25 °C / +77 °F (±5 K tolerance)	+15 °C / +59 °F (±5 K tolerance)	+50 °C / +122 °F (±7 K tolerance)	+40 °C / +104 °F (±6 K tolerance)

Art. No.	Contact maker (NO)		Contact maker (NO)	
	Switch-on temperature	Switch-off temperature	Switch-on temperature	Switch-off temperature
01164.0-00	+50 °C / +122 °F (±7 K tolerance)	+40 °C / +104 °F (±6 K tolerance)	+60 °C / +140 °F (±7 K tolerance)	+50 °C / +122 °F (±7 K tolerance)

Note: Other switch-off and switch-on temperatures on request.

MECHANICAL THERMOSTAT

FZK 011



- > Adjustable temperature
- > High switching capacity
- > Small hysteresis
- > Change-over contact
- > Clip fixing

The mechanical thermostat is used for controlling heating and cooling equipment, filter fans or signal devices. The thermostat registers the surrounding air and can switch both inductive and resistive loads via snap-action contact. Functionality: The temperature setting on the scale equals to the upper switch point, which means that the NC contact opens. The temperature setting minus switch temperature difference (and tolerances) equals to the lower switch point, which means that the NC contact closes.



TECHNICAL DATA

Switch temperature difference	5 K (-3/+2 K tolerance) ¹
Sensor element	thermostatic bimetal
Contact type	change-over snap-action contact
Service life	> 100,000 cycles
Min. switching capacity	10 mA
Max. switching capacity, NC	AC 250 V / AC 120 V, 10 (4) A DC 30 W
Max. switching capacity, NO	AC 250 V / AC 120 V, 5 (2) A DC 30 W
Max. inrush current	AC 16 A for 10 sec.
Connection	4-pole terminal, clamping torque 0.5 Nm max.: rigid/stranded ² wire 2.5 mm ² (AWG 14)
Mounting	clip for 35 mm DIN rail, EN 60715
Casing	plastic according to UL94 V-0, light grey
Dimensions	67 x 50 x 38 mm
Weight	approx. 0.1 kg
Fitting position	variable
Operating/Storage temperature	-45 to +65 °C (-49 to +149 °F)
Operating/Storage humidity	max. 90 % RH (non-condensing)
Protection type	IP20
Approvals	UL File No. E164104, EAC

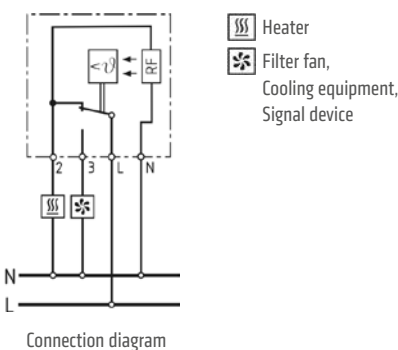
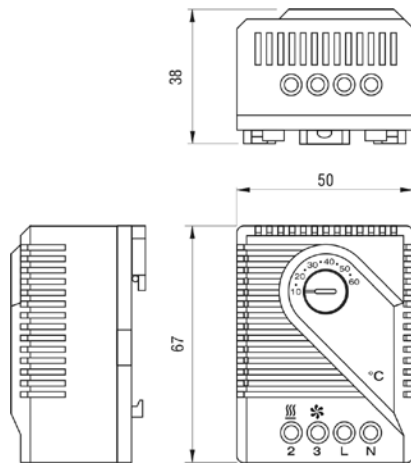

¹ If the Normally Closed contact is used, the switch temperature difference could be reduced by connecting terminal "N" (RF heating resistor). It causes the thermal feedback which is subject to surrounding conditions and thus has to be determined for each individual application.
² When connecting with wires, wire end ferrules must be used.

Important note: The contact system of the regulator is subjected to environmental influences, thus the contact resistance may change. This can lead to a voltage drop and/or self-heating of the contacts.

Art. No.	Operating voltage	Setting range
01170.0-00	AC 230 V	+5 to +60 °C
01170.0-01	AC 230 V	+40 to +140 °F
01170.0-02	AC 230 V	-20 to +35 °C
01170.9-00	AC 120 V	+40 to +140 °F
01170.9-01	AC 120 V	+5 to +60 °C

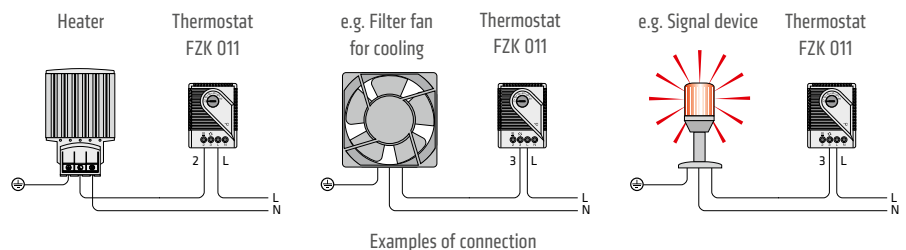

ELECTRONIC THERMOSTAT

ETR 011



- > Large setting range
- > Small hysteresis
- > Status indicator (LED)
- > Change-over contact
- > Clip fixing

The electronic thermostat is used for controlling heating and cooling equipment, filter fans or signal devices. The thermostat registers the surrounding air and can switch both inductive and resistive loads via relay with change-over contact. The LED integrated in the adjustment knob is lit when the NC is closed. (e.g. when a connected heater is operating).



TECHNICAL DATA

Switch temperature difference	4 K (± 1K tolerance) at +20 °C (+68 °F)
Sensor element	NTC
Reaction time	approx. 5 sec.
Contact type	change-over contact (relay)
Service life	> 50,000 cycles
Max. switching capacity (relay output)	AC 240 V / AC 120 V, 8 (1.6) A DC 100 W at DC 24 V
Max. inrush current	AC 16 A for 10 sec.
Optical indicator	LED
Connection	5-pole terminal, clamping torque 0.5 Nm max.: rigid/stranded ¹ wire 2.5 mm ² (AWG 14)
Mounting	clip for 35 mm DIN rail, EN 60715
Casing	plastic according to UL 94V-0, light grey
Dimensions	64.5 x 42 x 38 mm
Weight	approx. 70 g
Fitting position	vertical
Operating/Storage temperature	-40 to +85 °C (-40 to +185 °F)
Operating/Storage humidity	max. 90 % RH (non-condensing)
Protection type	IP20

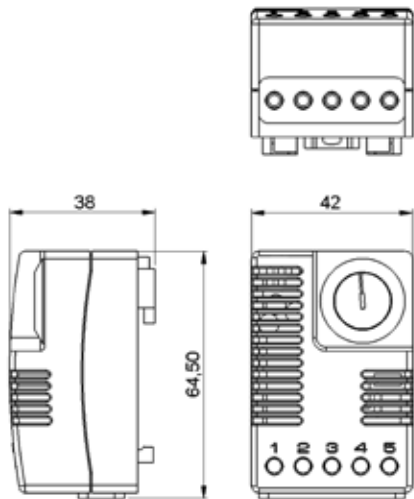

Connection diagram

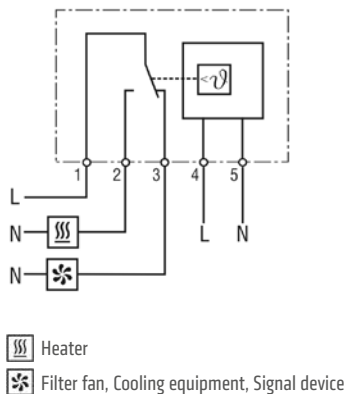

¹ When connecting with stranded wires, wire end ferrules must be used.

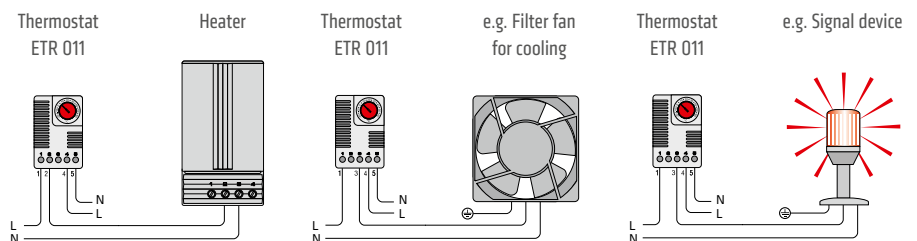

Examples of connection

Art. No.	Operating voltage	Setting range	Approvals		
01131.0-00	AC 230 V, 50/60 Hz	-20 to +60 °C	VDE	UL File No. E164102	EAC
01131.9-00	AC 120 V, 50/60 Hz	-4 to +140 °F	-	UL File No. E164102	EAC

ELECTRONIC THERMOSTAT

ET 011 | DC 24 V



- > High DC breaking capacity
- > Low hysteresis
- > Adjustable temperature
- > Change-over contact
- > Clip fixing

Electronic thermostat for regulating high performance DC 24 V equipment. Heating or cooling appliances as well as signal devices can be switched via the potential free change-over contact. In comparison to mechanical thermostats, the ET 011 has a low hysteresis making the switching point and setting accuracy more precise.



TECHNICAL DATA

Switch temperature difference	approx. 3 K
Sensor element	PTC
Contact type	change-over
Service life	> 100,000 cycles
Max. switching capacity	DC 28 V, 16 A
Max. inrush current	DC 16 A
Connection	5-pole terminal, clamping torque 0.5 Nm max.: rigid wire 2.5 mm ² (AWG 14) stranded wire ¹ 1.5 mm ² (AWG 16)
Mounting	clip for 35 mm DIN rail, EN 60715
Casing	plastic according to UL94 V-0, light grey
Dimensions	67 x 50 x 46 mm
Weight	approx. 80 g
Fitting position	vertical
Operating/Storage temperature	-40 to +60 °C (-40 to +140 °F) / -45 to +80 °C (-49 to +176 °F)
Operating/Storage humidity	max. 90 % RH (non-condensing)
Protection type	IP20
Approvals	EAC

¹ When connecting with stranded wires, wire end ferrules must be used.

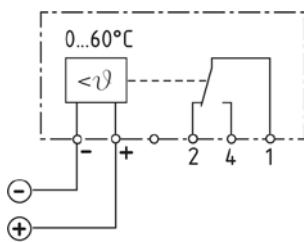
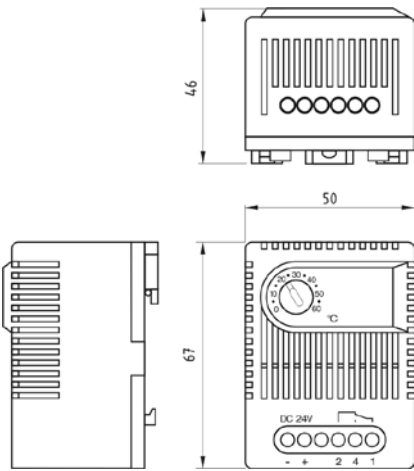

Connection diagram

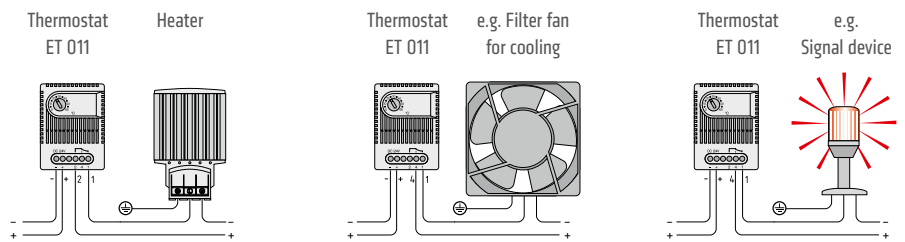

Examples of connection

Art. No.	Operating voltage	Setting range
01190.0-00	DC 24 V (DC 20 – 28 V)	0 to +60 °C

ELECTRONIC THERMOSTAT

ETL 011 | DC 12 to 48 V



- > Large setting range
- > Small hysteresis
- > Optical operating display (LED)
- > Change-over contact
- > Signal application

The electronic thermostat registers the surrounding air temperature and can switch a signal current via its internal relay with a potential-free change-over contact. Signal-processing devices can be controlled directly with the ETL 011. In order to control heating and cooling equipment, filter fans and signal devices the switch module DCM 010 or a similar device is needed. The LED integrated in the adjustment knob shows the closed status of the contact 1-2. When temperature is rising contact 1-2 opens and the LED turns off. In currentless state (no supply voltage) contact 1-2 opens.



TECHNICAL DATA

Switch temperature difference	4 K (± 1 K tolerance) at +20 °C (+68 °F)
Sensor element	NTC
Reaction time	approx. 5 sec.
Contact type	change-over contact (relay)
Service life	>100.000 cycles (at 10 mW)
Max. switching current (relay output)	DC 0.5 A at DC 48 V
Min. switching capacity	DC 10 mW (at 0.1 V, 100 mA or 1 mA, 10 V)
Optical indicator	LED
Connection	5-pole terminal, clamping torque 0.5 Nm max.: rigid wire/stranded wire ¹ 2.5 mm ² (AWG 14)
Mounting	clip for 35 mm DIN rail, EN 60715
Casing	plastic according to UL94 V-0, light grey
Dimensions	64.5 x 42 x 38 mm
Weight	approx. 70 g
Fitting position	vertical
Operating/Storage temperature	-40 to +85 °C (-40 to +185 °F)
Operating/Storage humidity	max. 90 % RH (non-condensing)
Protection type	IP20

¹ When connecting with wires, wire end ferrules must be used.

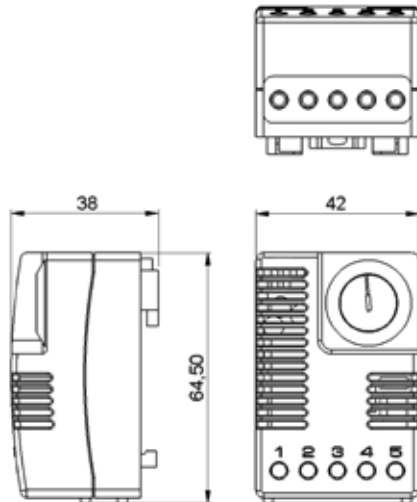

Connection diagram

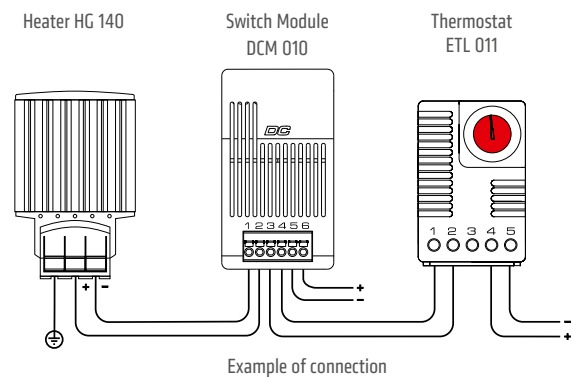
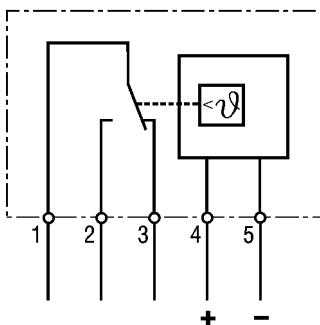

Art. No.	Operating voltage	Setting range	Approvals
01131.2-00	DC 12 – 48 V (min. DC 10 V, max. DC 60 V)	-20 to +60 °C	UL File No. E164102 EAC
01131.2-01	DC 12 – 48 V (min. DC 10 V, max. DC 60 V)	-4 to +140 °F	UL File No. E164102 EAC

MECHANICAL HYGROSTAT

MFR 012



- > Adjustable relative humidity
- > Change-over contact
- > High switching capacity
- > Easily accessible terminals
- > Clip fixing

The electromechanical hygrostat is designed to control enclosure heaters so that the dew point is raised when a critical relative humidity of 65 % is exceeded. In this way condensation and corrosion in enclosures with electric/ electronic components is effectively prevented.



TECHNICAL DATA

Switch difference ¹	4 % RH (±3 % tolerance)
Permissible air velocity	15 m/sec.
Contact type	change-over contact
Service life	> 50,000 cycles
Min. switching capacity	AC 20 V / DC 100 mA
Max. switching capacity	AC 250 V, 5 A DC 20 W
Connection	3-pole terminal for 2.5 mm ² , clamping torque 0.5 Nm max.: rigid wire 2.5 mm ² (AWG 14) stranded wire ² 1.5 mm ² (AWG 16)
Mounting	clip for 35 mm DIN rail, EN 60715
Casing	plastic according to UL94 V-0, light grey
Dimensions	67 x 50 x 38 mm
Weight	approx. 60 g
Fitting position	variable
Operating/Storage temperature	0 to +60 °C (+32 to +140 °F) / -40 to +60 °C (-40 to +140 °F)
Operating/Storage humidity	max. 95 % RH (non-condensing)
Protection type	IP20
Approvals	UL File No. E164102, EAC

¹ at 50 % RH

² When connecting with stranded wires, wire end ferrules must be used.

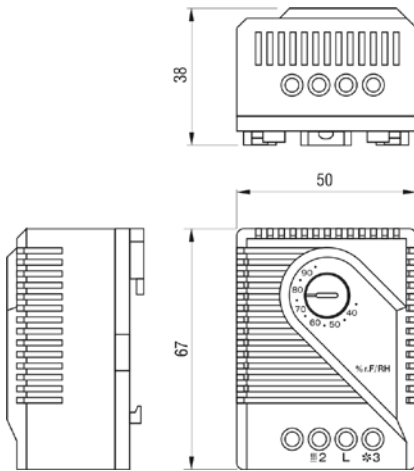

Connection diagram

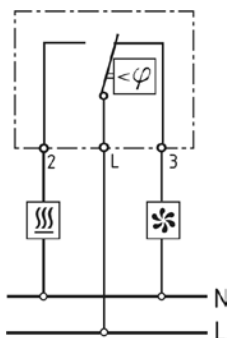

- Heater
- Filter fan, Cooling equipment, Signal device

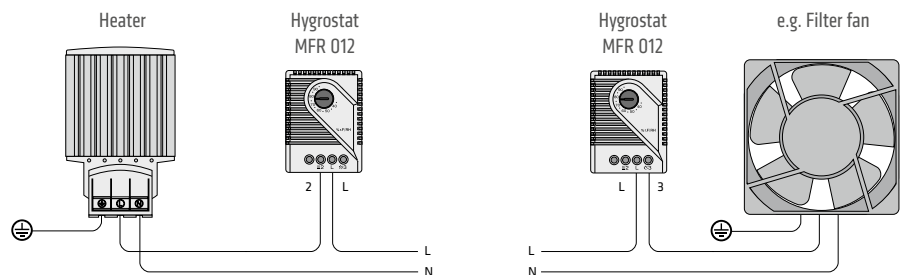

Examples of connection

Art. No. 01220.0-00	Setting range 35 to 95 % RH
------------------------	--------------------------------

ELECTRONIC HYGROSTAT

EFR 012



- > Adjustable and pre-set relative humidity
- > Status indicator (LED)
- > High switching capacity
- > Clip fixing
- > Temperature-compensated

The electronic hygrostat senses the relative humidity in an enclosure with electric/electronic components and turns on a heater at the set point, helping prevent the formation of condensation in the enclosure. The LED integrated in the adjustment knob is lit when the connected heater is in operation.



TECHNICAL DATA

Switch difference	5 % RH (± 3 % RH tolerance) at +25 °C (+77 °F), 50 % RH
Reaction time	5 sec.
Contact type	change-over contact (relay)
Service life	> 50,000 cycles
Max. switching capacity (relay output)	AC 240 V / AC 120 V 8 (1.6) A DC 100 W at DC 24 V
Max. inrush current	AC 16 A for 10 sec.
Optical indicator	LED
Connection	5-pole terminal, clamping torque 0.5 Nm max.: rigid/stranded ¹ wire 2.5 mm ² (AWG 14)
Mounting	clip for 35 mm DIN rail, EN 60715
Casing	plastic according to UL94 V-0, light grey
Dimensions	64.5 x 42 x 38 mm
Weight	approx. 70 g
Fitting position	vertical
Operating/Storage temperature	0 to +60 °C (+32 to +140 °F) / -20 to +70 °C (-4 to +158 °F)
Operating/Storage humidity	max. 90 % RH (non-condensing)
Protection type	IP20

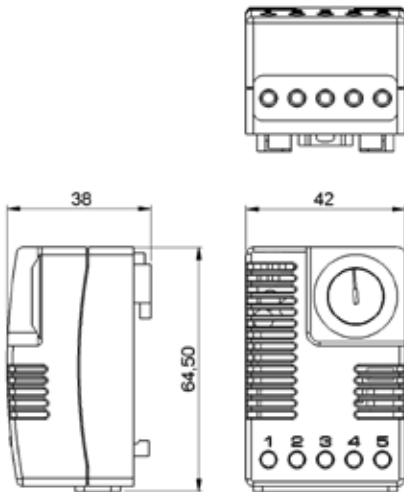

¹ When connecting with stranded wires, wire end ferrules must be used.

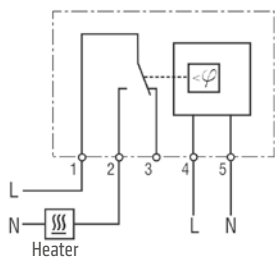

Connection diagram

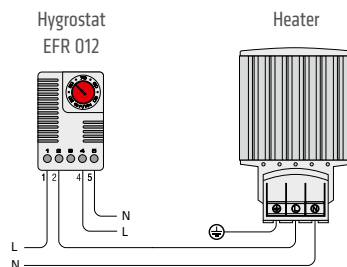

Example of connection

Art. No.	Operating voltage	Setting range	Approvals		
01245.0-00	AC 230 V, 50/60 Hz	40 to 90 % RH	VDE	UL File No. E164102	EAC
01246.0-00	AC 230 V, 50/60 Hz	65 % RH pre-set	VDE	UL File No. E164102	EAC
01246.0-01	AC 230 V, 50/60 Hz	50 % RH pre-set	VDE	UL File No. E164102	EAC
01245.9-00	AC 120 V, 50/60 Hz	40 to 90 % RH	-	UL File No. E164102	EAC
01246.9-00	AC 120 V, 50/60 Hz	65 % RH pre-set	-	UL File No. E164102	EAC

ELECTRONIC HYGROSTAT

EFL 012 | DC 12 to 48 V



- > Large setting range
- > Small hysteresis
- > Optical operating display (LED)
- > Change-over contact
- > Signal application

The electronic hygrostat registers the surrounding relative humidity and can switch a signal current via its internal relay with a potential-free change-over contact. Signal-processing devices can be controlled directly with the EFL 012. In order to control heating and cooling equipment, filter fans and signal devices the switch module DCM 010 or a similar device is needed. The LED integrated in the adjustment knob shows the closed status of the contact 1-2. When relative humidity drops contact 1-2 opens and the LED turns off. In currentless state (no supply voltage) contact 1-2 opens.



TECHNICAL DATA

Switch difference	5 % RH (±3 % RH tolerance) at +25 °C (+77 °F), 50 % RH
Reaction time	approx. 5 sec.
Contact type	change-over contact (relay)
Service life	>100.000 cycles (at 10 mW)
Max. switching current (relay output)	DC 0.5 A at DC 48 V
Min. switching capacity	DC 10 mW (at 0.1 V, 100 mA or 1 mA, 10 V)
Optical indicator	LED
Connection	5-pole terminal, clamping torque 0.5 Nm max.: rigid wire/stranded wire ¹ 2.5 mm ² (AWG 14)
Mounting	clip for 35 mm DIN rail, EN 60715
Casing	plastic according to UL94 V-0, light grey
Dimensions	64.5 x 42 x 38 mm
Weight	approx. 70 g
Fitting position	vertical
Operating/Storage temperature	0 to +60 °C (+32 to +140 °F) / -20 to +70 °C (-4 to +158 °F)
Operating/Storage humidity	max. 90 % RH (non-condensing)
Protection type	IP20

¹ When connecting with wires, wire end ferrules must be used.

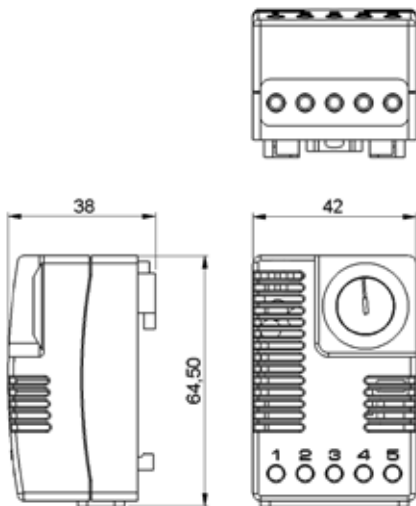

Connection diagram

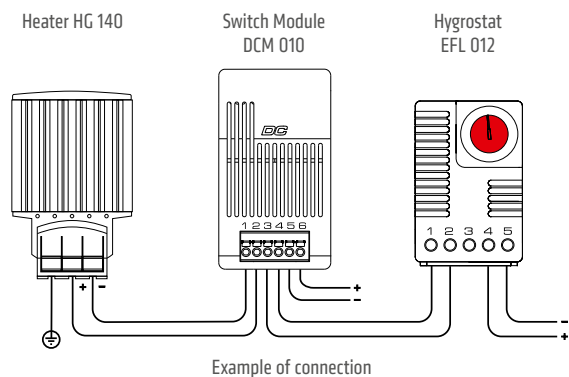
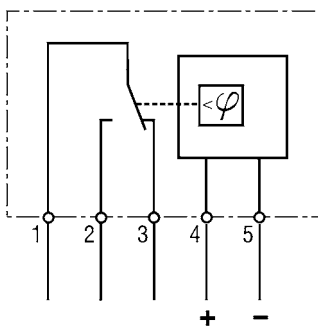

Art. No.	Operating voltage	Setting range	Approvals
01245.2-00	DC 12 – 48 V (min. DC 10 V, max. DC 60 V)	40 to 90 % RH	UL File No. E164102 EAC

ELECTRONIC HYGROTHERM

ETF 012



- > Temperature and humidity adjustable
- > Wide voltage range
- > Operating temperature down to -40 °C
- > High switching capacity
- > Status indicator (LED)

The electronic hygrotherm senses the ambient temperature and relative humidity in an enclosure with electric/electronic components and turns on a heater (or alternatively a fan) at either set point, helping prevent the formation of condensation in the enclosure. Due to its wide voltage range the hygrotherm can be utilised anywhere in the world. The LED integrated in the adjustment knob on the active controller is lit when the connected device is in operation.



TECHNICAL DATA

Switch difference (temperature)	2 K (± 1 K tolerance) at +25 °C (+77 °F), 50 % RH
Switch difference (humidity)	4 % RH (± 1 % tolerance) at +25 °C (+77 °F), 50 % RH
Reaction time (humidity)	approx. 5 sec.
Contact type	change-over contact (relay)
Service life	VDE: NO/NC > 15,000 cycles UL: NO/NC > 30,000 cycles
Max. switching capacity (relay output)	AC 240 V, 10 (1.6) A DC 60 V, 0.6 A ¹
Max. inrush current	AC 30 A for 10 sec.
Optical indicator	LED
Connection	5-pole terminal, clamping torque 0.5 Nm max.: rigid/stranded ² wire 2.5 mm ² (AWG 14)
Mounting	clip for 35mm DIN rail, EN 60715
Casing	plastic according to UL94 V-0, light grey
Dimensions	77 x 60 x 43 mm
Weight	approx. 0.2 kg
Fitting position	vertical
Operating/Storage temperature	-40 to +60 °C (-40 to +140 °F)
Operating/Storage humidity	max. 90 % RH (non-condensing)
Protection type	IP20
Approvals	VDE, UL File No. E164102, EAC

¹ not UL confirmed

² When connecting with stranded wires, wire end ferrules must be used.

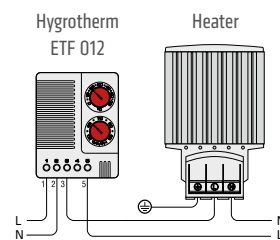
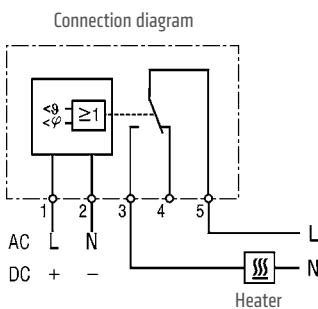
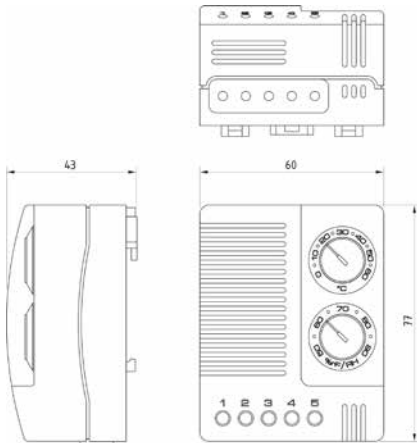

Example of connection

Art. No.	Operating voltage	Setting range temperature	Setting range humidity
01230.0-00	AC 100 – 240 V, 50/60 Hz (min. AC 90 V, max. AC 265 V)	0 to +60 °C	50 to 90 % RH
01230.9-00	AC 100 – 240 V, 50/60 Hz (min. AC 90 V, max. AC 265 V)	+32 to +140 °F	50 to 90 % RH
01230.1-00	DC 24 – 48 V (min. DC 20 V, max. DC 60 V)	0 to +60 °C	50 to 90 % RH

ELECTRONIC HYGROTHERM WITH EXTERNAL SENSOR

ETF 012



- > Temperature and humidity adjustable
- > Wide voltage range
- > Operating temperature down to -40 °C
- > High switching capacity
- > With external sensor

The electronic hygrotherm senses the ambient temperature and relative humidity in an enclosure with electric/electronic components and turns on a heater (or alternatively a fan) at either set point, helping prevent the formation of condensation in the enclosure. Due to its wide voltage range the hygrotherm can be utilised anywhere in the world. The external sensor can be positioned freely anywhere in the enclosure for precise measurements.



TECHNICAL DATA

Switch difference (temperature)	2 K (± 1 K tolerance) at +25 °C (+77 °F), 50 % RH
Switch difference (humidity)	4 % RH (± 1 % tolerance) at +25 °C (+77 °F), 50 % RH
Reaction time (humidity)	approx. 5 sec.
Contact type	change-over contact (relay)
Service life	VDE: NO/NC > 15,000 cycles UL: NO/NC > 30,000 cycles
Max. switching capacity (relay output)	AC 240 V, 10 (1.6) A DC 60 V, 0.6 A ¹
Max. inrush current	AC 30 A for 10 sec.
Optical indicator	LED
Connection	5-pole terminal, clamping torque 0.5 Nm max.: rigid/stranded ² wire 2.5 mm ² (AWG 14)
Mounting	clip for 35 mm DIN rail, EN 60715
Casing	plastic according to UL94 V-0, light grey
Dimensions	77 x 60 x 43 mm
Weight	approx. 0.2 kg
Fitting position	vertical
Operating/Storage temperature	-40 to +60 °C (-40 to +140 °F)
Operating/Storage humidity	max. 90 % RH (non-condensing)
Protection type	IP20
Approvals	VDE, UL File No. E164102, EAC

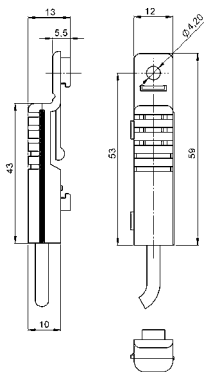
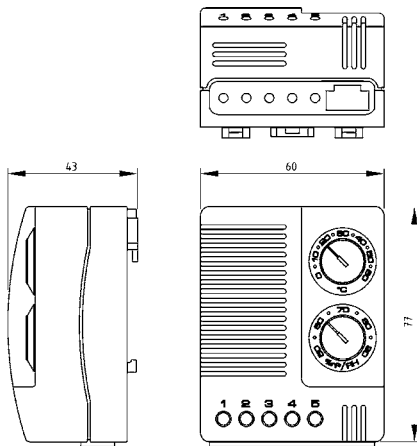

¹ not UL confirmed

² When connecting with stranded wires, wire end ferrules must be used.

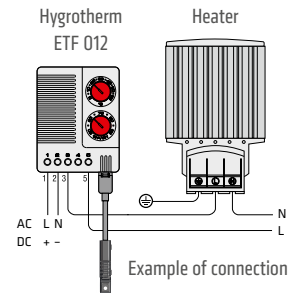
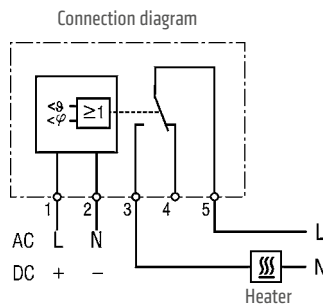

Art. No. Cable 1 m	Art. no. Cable 2 m	Operating voltage	Setting range temperature	Setting range humidity
01231.0-00	01231.0-01	AC 100 – 240 V, 50/60 Hz (min. AC 90 V, max. AC 265 V)	0 to +60 °C	50 to 90 % RH
01231.9-00	01231.9-01	AC 100 – 240 V, 50/60 Hz (min. AC 90 V, max. AC 265 V)	+32 to +140 °F	50 to 90 % RH
01231.1-00	01231.1-01	DC 24 – 48 V (min. DC 20 V, max. DC 60 V)	0 to +60 °C	50 to 90 % RH

SWITCH MODULE - DC LINE

DCM 010 | DC 20 to 56 V



- > High DC switching capacity
- > Variety of applications

- > Wide DC voltage range
- > Simple connection

The switch module is used to control DC powered devices with high capacities in control and switch cabinets. It is controlled via an external potential-free contact (thermostat or hygrostat), which is connected between terminal 3 and 4. It must be ensured that the external contact is suitable to switch the required signal current without any problems.



TECHNICAL DATA

Contact type	contact maker normally open (MOSFET)
Service life	> 100,000 cycles
Operating voltage	DC 20 to 56 V
Control contact – signal current	3 mA at DC 20 V / 4.5 mA at DC 24 V 14 mA at DC 48 V / 17 mA at DC 56 V
Connection	6-pole terminal: stranded wire ¹ 1.5 mm ² (AWG 16); max. 2.5 mm ² (AWG 12)
Mounting	clip for 35 mm DIN rail, EN 60715
Casing	plastic according to UL94 V-0, grey (bicolor)
Dimensions	93 x 53 x 44 mm
Weight	approx. 65 g
Fitting position	vertical
Operating temperature	see article table below
Storage temperature	-40 to +80 °C (-40 to +176 °F)
Operating / Storage humidity	max. 90 % RH (non-condensing)
Protection type	IP20
Approvals	UL File No. E342261, VDE, EAC
Note	other versions on request

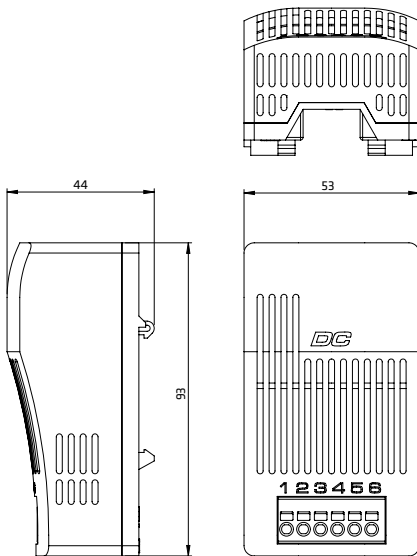

¹ When connecting with stranded wires, wire end ferrules must be used.

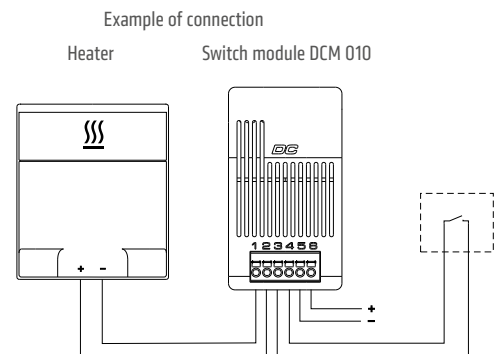
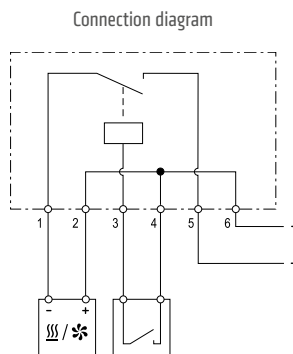

Art. No.	Max. switching capacity	Operating temperature
01010.0-00	DC 15 A	-40 to +40 °C (-40 to +104 °F)
01010.0-10	DC 13 A	-40 to +50 °C (-40 to +122 °F)
01010.0-20	DC 11 A	-40 to +60 °C (-40 to +140 °F)

ELECTRONIC THERMOSTAT – DC LINE

DCT 010 | DC 20 to 56 V



- > High DC switching capacity
- > Adjustable temperature
- > Small hysteresis
- > Optical operating display (LED)
- > Integrated switch module
- > Precise measurement via an external sensor

The electronic thermostat with integrated switch module is used to control DC powered devices with high capacities in control and switch cabinets. Heaters, coolers, filter fans or signal devices can directly be controlled via an internal electronic circuit. The external sensor can be positioned freely anywhere in the control cabinet for precise temperature measurements. Additionally, this thermostat is available in versions that not only measure temperature via the external sensor, but also the relative humidity.



TECHNICAL DATA

Switch difference (temperature)	3 K (± 1 K tolerance) at +25 °C (+77 °F), 50 % RH
Reaction time	approx. 5 sec.
External sensor	cable 2 m with snap in connector (included in the delivery)
Contact type	contact maker NO (MOSFET) or contact breaker NC (MOSFET)
Service life	> 100,000 cycles
Operating voltage	DC 20 to 56 V
Optical indicator	LED
Connection	6-pole terminal: stranded wire ¹ 1.5 mm ² (AWG 16); max. 2.5 mm ² (AWG 12)
Mounting	clip for 35 mm DIN rail, EN 60715
Casing	plastic according to UL94 V-0, grey (bicolor)
Dimensions	93 x 53 x 44 mm
Weight	approx. 120 g (incl. sensor)
Fitting position	vertical
Storage temperature	-40 to +80 °C (-40 to +176 °F)
Operating / Storage humidity	max. 90 % RH (non-condensing)
Protection type	IP20
Approvals	UL File No. E164102, VDE, EAC
Note	other versions (e.g. setting ranges and °F) on request

¹ When connecting with stranded wires, wire end ferrules must be used.

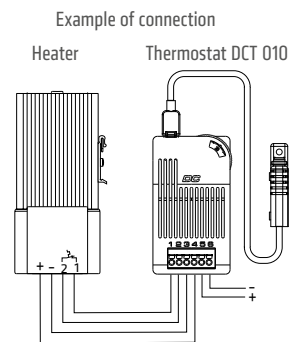
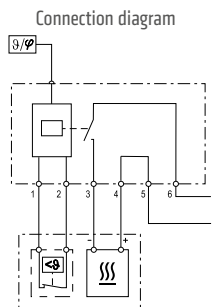
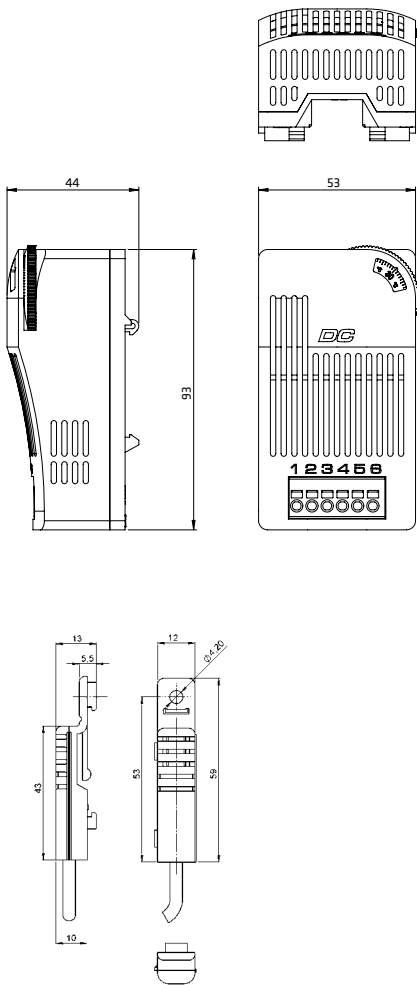

Art. No.	Max. switching capacity	Operating temperature	Primary switching function setting range temperature	Secondary switching function ² humidity setting	Contact (primary)
01011.0-21	DC 13 A	-40 to +50 °C (-40 to +122 °F)	-10 to +50 °C	-	Contact maker (NO)
01011.0-22	DC 11 A	-40 to +60 °C (-40 to +140 °F)	0 to +60 °C	-	Contact maker (NO)
01011.0-41	DC 13 A	-40 to +50 °C (-40 to +122 °F)	-10 to +50 °C	65 % RH pre-set	Contact breaker (NC)
01011.0-42	DC 11 A	-40 to +60 °C (-40 to +140 °F)	0 to +60 °C	65 % RH pre-set	Contact breaker (NC)

² Versions with secondary switching function can also register the humidity and therefore offer an additional protection for electronics. Switch difference: 4 % RH (± 1 % tolerance) at +25 °C (+77 °F), 50 % RH.

ELECTRONIC HYGROSTAT - DC LINE

DCF 010 | DC 20 to 56 V



- > High DC switching capacity
- > Adjustable humidity
- > Small hysteresis
- > Optical operating display (LED)
- > Integrated switch module
- > Precise measurement via an external sensor

The electronic hygrostat with integrated switch module is used to control DC powered devices with high capacities in control and switch cabinets. Heaters, coolers, filter fans or signal devices can directly be controlled via an internal electronic circuit. The external sensor can be positioned freely anywhere in the control cabinet for precise measurement of the atmospheric humidity. Additionally, this hygrostat is available in versions that not only measure the relative humidity via the external sensor, but also the temperature.



TECHNICAL DATA

Switch difference (humidity)	4 % RH (±1 % tolerance) at +25 °C (+77 °F), 50 % RH
Reaction time	approx. 5 sec.
External sensor	cable 2 m with snap in connector (included in the delivery)
Contact type	contact maker NO (MOSFET) or contact breaker NC (MOSFET)
Service life	> 100,000 cycles
Operating voltage	DC 20 to 56 V
Optical indicator	LED
Connection	6-pole terminal: stranded wire ¹ 1.5 mm ² (AWG 16); max. 2.5 mm ² (AWG 12)
Mounting	clip for 35 mm DIN rail, EN 60715
Casing	plastic according to UL94 V-0, grey (bicolor)
Dimensions	93 x 53 x 44 mm
Weight	approx. 120 g (incl. sensor)
Fitting position	vertical
Storage temperature	-40 to +80 °C (-40 to +176 °F)
Operating / Storage humidity	max. 90 % RH (non-condensing)
Protection type	IP20
Approvals	UL File No. E164102, VDE, EAC
Note	other versions on request

¹When connecting with stranded wires, wire end ferrules must be used.

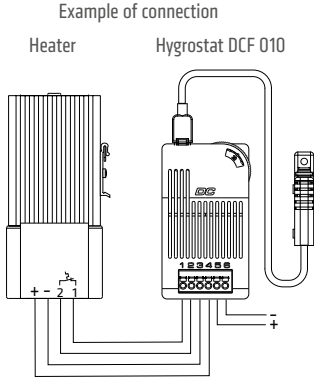
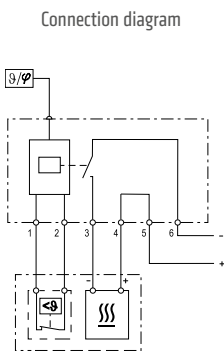
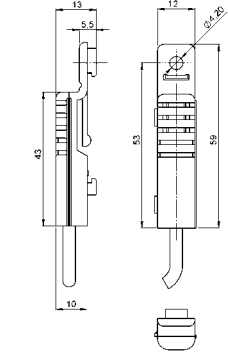
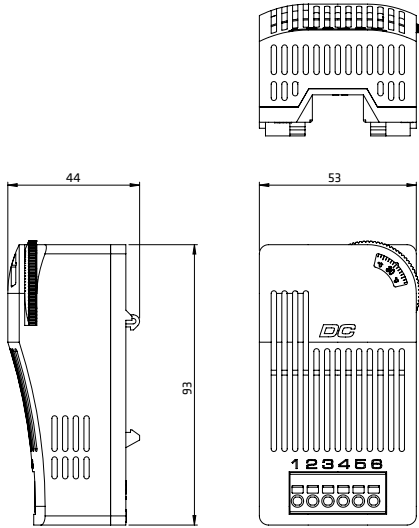

Art. No.	Max. switching capacity	Operating temperature	Primary switching function setting range humidity	Secondary switching function ² Switch-on temperature	Contact (primary)
01012.0-20	DC 15 A	-40 to +40 °C (-40 to +104 °F)	40 to 90 % RH	+5 °C (+41 °F) pre-set	Contact maker (NO)
01012.0-21	DC 13 A	-40 to +50 °C (-40 to +122 °F)	40 to 90 % RH	+5 °C (+41 °F) pre-set	Contact maker (NO)
01012.0-22	DC 11 A	-40 to +60 °C (-40 to +140 °F)	40 to 90 % RH	+5 °C (+41 °F) pre-set	Contact maker (NO)

²Versions with secondary switching function can also register the temperature and therefore offer an additional protection for electronics. Switch difference: 3 K (±1K tolerance) at +25 °C (+77 °F), 50 % RH.

SMART SENSOR

CSS 014 | DC 24 V



- > Analog/digital interface
- > Small size
- > Easy clip and/or screw fixing
- > Quick connection (M12 plug-in connector)
- > High accuracy
- > Large temperature and humidity range
- > Various application areas (IEC 61010-1/DIN EN 61010-1)

The compact Smart Sensor CSS 014 electronically records temperature and humidity and converts the measured data into a standardized analog 4-20 mA or a digital IO-Link signal. The converted value signals can be utilized or further processed by a control or monitoring unit, e.g. a PLC control. The Smart Sensor is suitable for installation inside and outside the enclosure, even in harsh environmental conditions as can be found in the wind power industry: in shielded outdoor areas and exposed to vibrations.



TECHNICAL DATA

Measuring signals	analog (4-20 mA) / digital (IO-Link)	temperature, humidity events, diagnosis, device data
Max. reaction time		3 min.
Load resistance (external)		≤ 500 Ω (4-20 mA only)
Connection		M12 round plug connector, IEC 61076-2-101, 4-pin, A-coded, shielded
Electrical protection		Reverse-polarity, short circuit, overvoltage protection
Mounting		clip for 35 mm DIN rail, EN 60715 and screw fixing M5
Casing		plastic according to UL94 V-0, light grey
Dimensions		140 x 40 x 38 mm
Weight		approx. 50 g
Fitting position		vertical, connection on top
Storage temperature		-40 to +85 °C (-40 to +185 °F)
Operating/Storage humidity		max. 90 % RH (non-condensing)
Protection type ¹ /Protection class		IP20 (sensor only IP57) / III (SELV)
Approvals		VDE and UL File No. E500143 (acc. to IEC 61010-1/DIN EN 61010-1)
Note		other measuring ranges on request

¹The PCB (printed circuit board) is coated on both sides with a certified protective lacquer to protect against corrosion and for improvement of the tracking resistance.

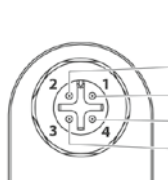
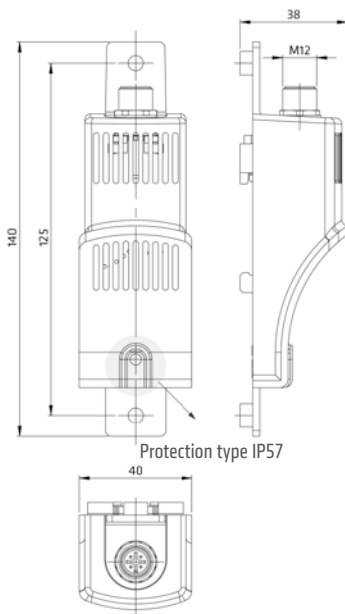

Pin assignment for 4-pin M12 round plug connector

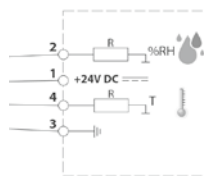

analog 4-20 mA

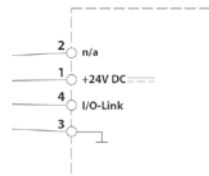

IO-Link

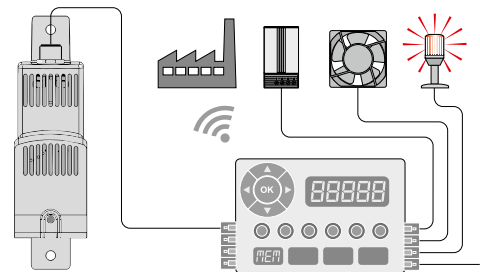

Example of connection

Art. No.	Interface	Operating voltage	Power consumption max.	Temperature measuring range	Humidity measuring range	Operating temperature
01420.2-00	4-20 mA (analog)	DC 24 V (DC 12-30 V)	1.8 W (typically 0.4 W)	-40 to +60 °C (-40 to +144 °F) ± 1 K	0 to 100 % RH ± 4% ²	-40 to +70 °C (-40 to +158 °F)
01411.2-00	IO-Link (digital, specified acc. to version 1.1)	DC 24 V (DC 18-30 V)	0.3 W	-40 to +80 °C (-40 to +176 °F) ± 0.3 K	0 to 100% RH ± 3% ²	-40 to +80 °C (-40 to +176 °F)

²Tolerance within 20 to 80 % RH (please request diagram for tolerances outside this range).



LIGHTING

IDEAL LIGHTING SOLUTIONS

Our lighting solutions ensure that maintenance on electronic installations can be carried out night and day.

VARIOLINE LAMP

LED 021/022

LED 021
Movement sensor and
screw fixing

LED 022
On/off switch
and magnet fixing

- > High luminous flux
- > Integrated power unit
- > Durable and maintenance-free LED technology
- > Daisy chain
- > On/off switch or movement sensor
- > Magnet or screw fixing

The LED 021/022 Varioline is a powerful and compact LED lamp for use in enclosures. Its LED tube emits more than 1,000/1,700 Lm at only 11 W/16 W power consumption, thereby illuminating even very large enclosures in their full depth and height. The glare-free, 360° rotatable LED tube uses Mid-power LEDs with a service life of 60,000 h. The emitted daylight color of 6,500 K provides safety for the user by a natural and non-fading color reproduction.



TECHNICAL DATA

Power consumption	max. 11 W/16 W
Operating voltage	AC 100 – 240 V, 50/60 Hz (min. AC 90 V, max. AC 265 V)
Luminous flux	1,080 Lm/1,730 Lm
Lamp type	LED, angle of radiation 120° light color: daylight, color temperature: 6,500 K
Service life	60,000 h at +20 °C (+68 °F)
Connection	2-pole connector with snap lock AC: max. 2.5 A / AC 240 V, color: white
Mounting	magnet fixing or screw fixing (M5), torque 2 Nm max.
Casing	plastic, translucent
Dimensions	see drawings
Weight	approx. 0.2 kg/0.3 kg
Operating/Storage temperature	-30 to +40 °C (-22 to +104 °F) / -40 to +85 °C (-40 to +185 °F)
Operating/Storage humidity	max. 90 % RH (non-condensing)
Protection type/Protection class	IP20 / II (double insulated)

Mounting options: The lamps are available with magnet fixing for easy positioning in any steel cabinet or enclosure. A classic is the LED 021/022 with screw fixing. With a total rotation angle of 360° it provides perfect illumination.

Note: The lamp must not be used for household lighting.



LED 021/022
magnet or
screw fixing

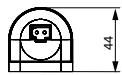

LED 021/022
side view

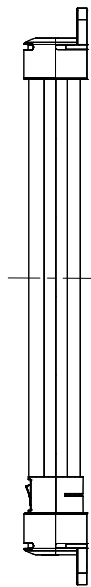
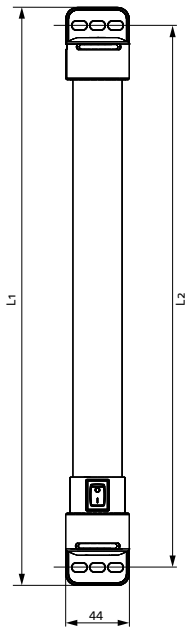

LED 021 (Size 1)
L1 = 400 mm
L2 = 375 mm

LED 022 (Size 2)
L1 = 600 mm
L2 = 575 mm

View of magnet fixing

View of screw fixing

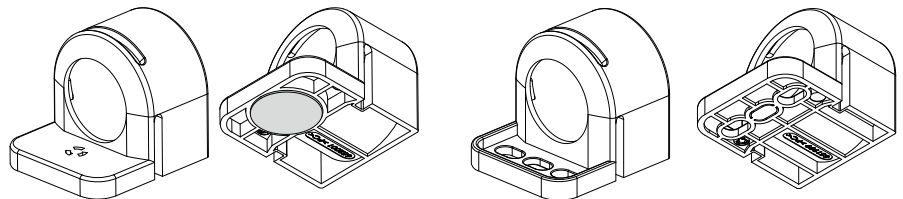

Size 1: L1 = 400 mm		Size 2: L1 = 600 mm		Switch	Approvals		
Art. No. Magnet fixing	Art. No. Screw fixing	Art. No. Magnet fixing	Art. No. Screw fixing				
02100.0-30	02100.0-00	02200.0-30	02200.0-00	On/off switch	VDE	UL File No. E234324	EAC
02110.0-30	02110.0-00	02210.0-30	02210.0-00	PIR movement sensor ¹	VDE	UL File No. E234324	EAC
02120.0-30	02120.0-00	02220.0-30	02220.0-00	without switching option	VDE	UL File No. E234324	EAC

¹ approx. 5 min. fixed switch-on duration

ACCESSORIES LED 021/022

Connectors and cables for electrical connection are not included in the delivery of the LED 021/022. These parts can be ordered separately. Sets, consisting of lamp and accessories, are available on request. Likewise, custom cables are available on request.

LAMP-SET WITH FEMALE CONNECTOR

▶ Varioline LED enclosure lamps are also available as a set including the connector Art. No. 264057. Simply add -0003 to the article number of the required lamp. For example: 02100.0-30-0003

FEMALE / MALE CONNECTORS



Photo: Female connector, Art. No. 264057



Photo: Male connector, Art. No. 264058

Art. No.	Model	Voltage type	Color	Use for	Wire cross-section ¹	Approvals
264057	female connector	AC	white	power input	0,5-2,5 mm ² (AWG 14-20)	VDE + UL
264058	male connector	AC	white	power output	0,5-2,5 mm ² (AWG 14-20)	VDE + UL

¹ applies to rigid and stranded wire. Wire end ferrules must be used when connecting with stranded wires

CONNECTION CABLE WITH FEMALE CONNECTOR AND OPEN END



Photo: Connection cable, Art. No. 244356

Art. No.	Model	Length	Voltage type	Color	Use for	Approvals ²
244356	connection cable 2 x 1.5 mm ² with female connector	2.0 m	AC	connector: white; cable: white	power input	VDE
244357	connection cable 2 x AWG 16 with female connector	2.0 m	AC	connector: white; cable: white	power input	VDE + UL

² applies only to the individual components (cable and connectors)

EXTENSION CABLE WITH 2 CONNECTORS FOR DAISY CHAIN CONNECTION

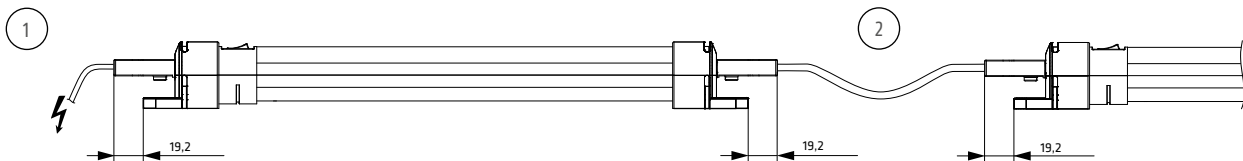

Photo: Extension cable, Art. No. 244358

Art. No.	Model	Length	Voltage type	Color	Use for	Approvals ²
244358	extension cable 2 x 1.5 mm ² with 2 connectors	1.0 m	AC	connectors: white; cable: white	daisy chain	VDE
244359	extension cable 2 x AWG 16 with 2 connectors	1.0 m	AC	connectors: white; cable: white	daisy chain	VDE + UL

² applies only to the individual components (cable and connectors)

CONNECTION EXAMPLE



This illustration shows the LED 021/022 lamp in a daisy chain application. The lamps are conveniently connected via connection plugs - up to 8 lamps max. can be daisy-chained this way. The snap lock connectors ensure a stable electrical connection even if subjected to heavy vibration. The connection example shows a AC 230 V application, using the following cables: connection cable with female connector, Art. No. 244356 (1); daisy chain extension cable with 2 connectors, Art. No. 244358 (2).

Female/male connectors are also available to assemble cables in non-standard lengths.

VARIOLINE LAMP WITH SOCKET

LED 121/122

LED 121
On/off switch and
screw fixing

LED 122
Movement sensor and
magnet fixing



LED 121/122
magnet/screw
fixing

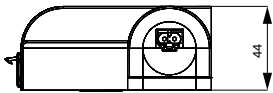

LED 121/122
side view

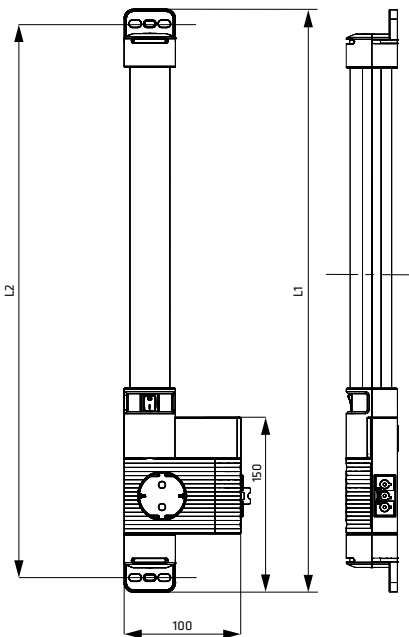

LED 121 (Size 1)
L1 = 500 mm
L2 = 475 mm

LED 122 (Size 2)
L1 = 700 mm
L2 = 675 mm

- > High luminous flux
- > Integrated socket
- > Durable and maintenance free LED technology

- > Integrated power unit
- > Daisy chain
- > On/off switch, movement sensor or connection for external door switch

The LED 121/122 Varioline is a powerful and compact LED lamp with integrated socket for use in enclosures. Featuring socket standards of many European countries as well as the US and Australia, it allows for the power connection of laptops and diagnostic devices. Its LED tube emits more than 1,000/1,700 Lm thereby illuminating even very large enclosures in their full depth and height. The glare-free, 120° rotatable light tube uses Mid-power LEDs with a service life of 60,000 h.



TECHNICAL DATA

Power consumption	max. 11 W/16 W
Operating voltage	AC 220 - 240 V, 50/60 Hz (min. AC 200 V, max. AC 265 V) AC 120 V, 50/60 Hz (min. AC 110 V, max. AC 130 V)
Luminous flux	1,080 Lm/1,730 Lm
Lamp type	LED, angle of radiation 120° light color: daylight, color temperature: 6,500 K
Service life	60,000 h at +20 °C (+68 °F)
Connection	3-pole connector with snap lock AC: max. 16 A / AC 240 V, color: white
Mounting	magnet fixing or screw fixing (M5), torque 2 Nm max.
Casing	plastic, translucent
Dimensions	see drawings
Weight	approx. 0.3 kg/0.4 kg
Operating/Storage temperature	-30 to +40 °C (-22 to +104 °F) / -40 to +85 °C (-40 to +185 °F)
Operation/Storage humidity	max. 90 % RH (non-condensing)
Protection type/Protection class	IP20 / I (earthed)

Mounting options: The lamps are available with magnet fixing for easy positioning in any steel cabinet or enclosure. A classic is the LED 121/122 with screw fixing. With a total rotation angle of 120° it provides perfect illumination.

Note: The lamp must not be used for household lighting.

View of magnet fixing

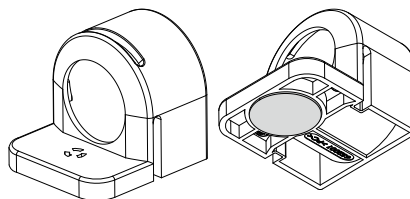

View of screw fixing

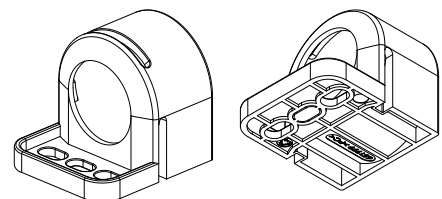

VARIOLINE LED 121/122 ON/OFF SWITCH

Size 1: L1 = 500 mm		Size 2: L1 = 700 mm		Operating voltage	Socket	Nominal current of socket	Approvals		
Art. No. Magnet fixing	Art. No. Screw fixing	Art. No. Magnet fixing	Art. No. Screw fixing						
12100.0-30	12100.0-00	12200.0-30	12200.0-00	AC 220 – 240 V, 50/60 Hz	Germany/Russia (1)	16.0 A	VDE	-	EAC
12101.0-30	12101.0-00	12201.0-30	12201.0-00	AC 220 – 240 V, 50/60 Hz	FR/PL/CZ/SK (2)	16.0 A	VDE	-	EAC
12102.0-30	12102.0-00	12202.0-30	12202.0-00	AC 220 – 240 V, 50/60 Hz	Switzerland (3)	10.0 A	-	-	EAC
12103.0-30	12103.0-00	12203.0-30	12203.0-00	AC 220 – 240 V, 50/60 Hz	UK/Ireland (4)	13.0 A	VDE	-	EAC
12104.0-30	12104.0-00	12204.0-30	12204.0-00	AC 120 V, 50/60 Hz	USA/Canada (5)	15.0 A	-	UL File No. E234324	EAC
12105.0-30	12105.0-00	12205.0-30	12205.0-00	AC 220 – 240 V, 50/60 Hz	Italy (6)	16.0 A	VDE	-	EAC
12107.0-30	12107.0-00	12207.0-30	12207.0-00	AC 220 – 240 V, 50/60 Hz	Australia (7)	10.0 A	VDE	-	EAC

VARIOLINE LED 121/122 PIR MOVEMENT SENSOR¹

Size 1: L1 = 500 mm		Size 2: L1 = 700 mm		Operating voltage	Socket	Nominal current of socket	Approvals		
Art. No. Magnet fixing	Art. No. Screw fixing	Art. No. Magnet fixing	Art. No. Screw fixing						
12110.0-30	12110.0-00	12210.0-30	12210.0-00	AC 220 – 240 V, 50/60 Hz	Germany/Russia (1)	16.0 A	VDE	-	EAC
12111.0-30	12111.0-00	12211.0-30	12211.0-00	AC 220 – 240 V, 50/60 Hz	FR/PL/CZ/SK (2)	16.0 A	VDE	-	EAC
12112.0-30	12112.0-00	12212.0-30	12212.0-00	AC 220 – 240 V, 50/60 Hz	Switzerland (3)	10.0 A	-	-	EAC
12113.0-30	12113.0-00	12213.0-30	12213.0-00	AC 220 – 240 V, 50/60 Hz	UK/Ireland (4)	13.0 A	VDE	-	EAC
12114.0-30	12114.0-00	12214.0-30	12214.0-00	AC 120 V, 50/60 Hz	USA/Canada (5)	15.0 A	-	UL File No. E234324	EAC
12115.0-30	12115.0-00	12215.0-30	12215.0-00	AC 220 – 240 V, 50/60 Hz	Italy (6)	16.0 A	VDE	-	EAC
12117.0-30	12117.0-00	12217.0-30	12217.0-00	AC 220 – 240 V, 50/60 Hz	Australia (7)	10.0 A	VDE	-	EAC

¹ approx. 5 min fixed switch-on duration

VARIOLINE LED 121/122 WITH CONNECTION FOR EXTERNAL DOOR SWITCH

Size 1: L1 = 500 mm		Size 2: L1 = 700 mm		Operating voltage	Socket	Nominal current of socket	Approvals		
Art. No. Magnet fixing	Art. No. Screw fixing	Art. No. Magnet fixing	Art. No. Screw fixing						
12120.0-30	12120.0-00	12220.0-30	12220.0-00	AC 220 – 240 V, 50/60 Hz	Germany/Russia (1)	16.0 A	VDE	-	EAC
12121.0-30	12121.0-00	12221.0-30	12221.0-00	AC 220 – 240 V, 50/60 Hz	FR/PL/CZ/SK (2)	16.0 A	VDE	-	EAC
12122.0-30	12122.0-00	12222.0-30	12222.0-00	AC 220 – 240 V, 50/60 Hz	Switzerland (3)	10.0 A	-	-	EAC
12123.0-30	12123.0-00	12223.0-30	12223.0-00	AC 220 – 240 V, 50/60 Hz	UK/Ireland (4)	13.0 A	VDE	-	EAC
12124.0-30	12124.0-00	12224.0-30	12224.0-00	AC 120 V, 50/60 Hz	USA/Canada (5)	15.0 A	-	UL File No. E234324	EAC
12125.0-30	12125.0-00	12225.0-30	12225.0-00	AC 220 – 240 V, 50/60 Hz	Italy (6)	16.0 A	VDE	-	EAC
12127.0-30	12127.0-00	12227.0-30	12227.0-00	AC 220 – 240 V, 50/60 Hz	Australia (7)	10.0 A	VDE	-	EAC

VARIOLINE LED 121/122 WITHOUT SWITCHING OPTION

Size 1: L1 = 500 mm		Size 2: L1 = 700 mm		Operating voltage	Socket	Nominal current of socket	Approvals		
Art. No. Magnet fixing	Art. No. Screw fixing	Art. No. Magnet fixing	Art. No. Screw fixing						
12130.0-30	12130.0-00	12230.0-30	12230.0-00	AC 220 – 240 V, 50/60 Hz	Germany/Russia (1)	16.0 A	VDE	-	EAC
12131.0-30	12131.0-00	12231.0-30	12231.0-00	AC 220 – 240 V, 50/60 Hz	FR/PL/CZ/SK (2)	16.0 A	VDE	-	EAC
12132.0-30	12132.0-00	12232.0-30	12232.0-00	AC 220 – 240 V, 50/60 Hz	Switzerland (3)	10.0 A	-	-	EAC
12133.0-30	12133.0-00	12233.0-30	12233.0-00	AC 220 – 240 V, 50/60 Hz	UK/Ireland (4)	13.0 A	VDE	-	EAC
12134.0-30	12134.0-00	12234.0-30	12234.0-00	AC 120 V, 50/60 Hz	USA/Canada (5)	15.0 A	-	UL File No. E234324	EAC
12135.0-30	12135.0-00	12235.0-30	12235.0-00	AC 220 – 240 V, 50/60 Hz	Italy (6)	16.0 A	VDE	-	EAC
12137.0-30	12137.0-00	12237.0-30	12237.0-00	AC 220 – 240 V, 50/60 Hz	Australia (7)	10.0 A	VDE	-	EAC

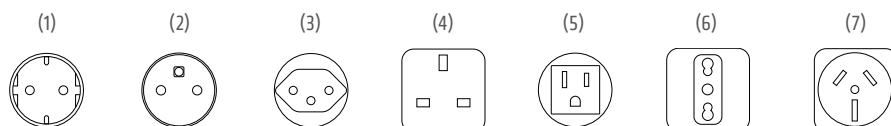

ACCESSORIES LED 121/122

Connectors and cables for electrical connection are not included in the delivery of the LED 121/122. These parts can be ordered separately. Sets, consisting of lamp and accessories, are available on request. Likewise, custom cables are available on request.

LAMP-SET WITH FEMALE CONNECTOR

▶ Varioline LED enclosure lamps are also available as a set including the connector Art. No. 264093. Simply add **-0003** to the article number of the required lamp. For example: 12100.0-30-**0003**. Sets for lamps with external door switch contain in addition the male connector 264090.

FEMALE / MALE CONNECTORS



Photo: Female connector, Art. No. 264093



Photo: Female connector, Art. No. 264091



Photo: Male connector, Art. No. 264090

Art. No.	Model	Voltage type	Color	Use for	Wire cross-section ¹	Approvals
264093	female connector	AC	white	power input and daisy chain	0,75-2,5 mm ² (AWG 14-18)	VDE + UL
264091	female connector	AC	white	power input	0,75-2,5 mm ² (AWG 14-18)	VDE + UL
264090	male connector	AC	grey	door switch	0,5-2,5 mm ² (AWG 14-20)	VDE + UL

¹ applies to rigid and stranded wire. Wire end ferrules must be used when connecting with stranded wires

CONNECTION CABLE WITH FEMALE CONNECTOR AND OPEN END



Photo: Connection cable, Art. No. 244422

Art. No.	Model	Length	Color	Use for	Approvals ²
244422	connection cable 3 x 1.5 mm ² with female connector	4.0 m	connector: white; cable: white	power input	VDE
244423	connection cable 3 x AWG 16 with female connector	4.0 m	connector: white; cable: white	power input	VDE + UL

² applies only to the individual components (cable and connectors)

EXTENSION CABLE WITH 2 CONNECTORS FOR DAISY CHAIN CONNECTION



Photo: Extension cable, Art. No. 244358

Art. No.	Model	Length	Color	Use for	Approvals ²
244358	extension cable 2 x 1.5 mm ² with 2 connectors	1.0 m	connectors: white; cable: white	daisy chain	VDE
244359	extension cable 2 x AWG 16 with 2 connectors	1.0 m	connectors: white; cable: white	daisy chain	VDE + UL

² applies only to the individual components (cable and connectors)

CONNECTION CABLE WITH MALE CONNECTOR AND OPEN END

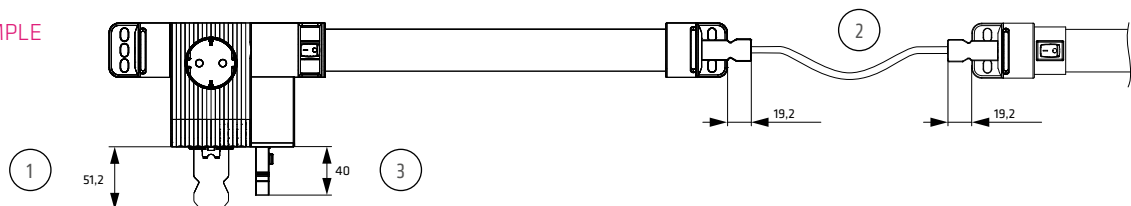

Photo: Connection cable, Art. No. 244424

Art. No.	Model	Length	Color	Use for	Approvals ²
244424	connection cable 2 x 1.5 mm ² with male connector	0.6 m	male connector: grey; cable: white	power output	VDE
244425	connection cable 2 x AWG 16 with male connector	0.6 m	male connector: grey; cable: white	power output	VDE + UL

² applies only to the individual components (cable and connectors)

CONNECTION EXAMPLE



The lamps are conveniently connected via connection plugs - up to 8 lamps max. can be daisy-chained this way. Female/male connectors are also available to assemble cables in non-standard lengths.

ECOLINE LAMP

LED 025



- > Wide voltage range
- > Integrated power unit
- > Dual pressure connection clamp
- > Daisy chain
- > Magnet, screw or clip fixing
- > Long-lived and maintenance-free by LED technology

The lamp series LED 025 is suitable for all types of panels and enclosures, especially where space is at a premium. The lamps have a very long service life thanks to the use of LED technology. Three different fixing options provide more flexibility for installation. The Ecoline series is a simplified version of the standard LED 025 lamp and has a dual pressure clamp for connection instead of connectors. Nonetheless it is suitable for daisy-chaining and allows for up to 10 lamps to be connected to each other.



TECHNICAL DATA

Power consumption	max. 5 W
Luminous flux	400 Lm at 120°
Lamp type	LED, angle of radiation 120° light color: daylight, color temperature: 6,000 K to 7,000 K
Service life	60,000 h at +20 °C (+68 °F)
Connection	2-pole dual pressure clamp for rigid wire 2.5 mm ² , stranded wire (with wire end ferrule) 1.5 mm ²
Mounting	magnet fixing or screw fixing (M5), clip fixing (M6), torque 2 Nm max.
Casing	plastic, transparent
Dimensions	see drawings
Weight	0.2 kg
Operating/Storage temperature	-30 to +60 °C (-22 to +140 °F) / -40 to +85 °C (-40 to +185 °F)
Operating/Storage humidity	max. 90 % RH (non-condensing)
Protection type/Protection class	IP20 / II (double insulated)

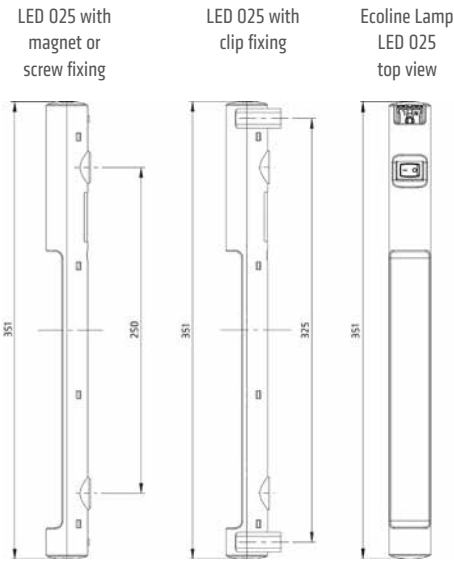

Mounting options: The lamps are available with magnet fixing for easy positioning in any steel cabinet or enclosure. A classic is the LED 025 with screw fixing. The clip holders exclusively designed for clip fixing of the LED 025 can be positioned anywhere in the cabinet by simply screwing the holders to the cabinet wall. The lamp is snapped into the clip holders and can be turned in both directions. With a total rotation angle of 180° it provides perfect illumination within the cabinet or enclosure.

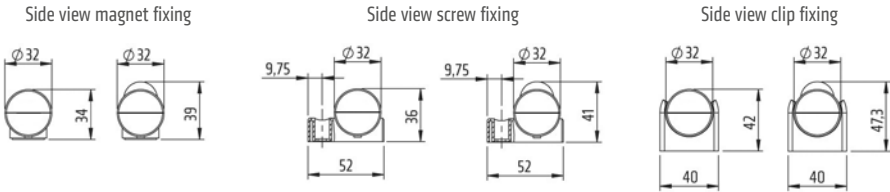

Art. No. Magnet fixing	Art. No. Screw fixing	Art. No. Clip fixing	Operating voltage	Switch	Approvals		
02540.3-10	02540.3-11	02540.3-13	AC 100 – 240 V, 50/60 Hz (min. AC 90 V, max. AC 265 V) DC 90 – 110 V (min. DC 80 V, max. DC 125 V)	on/off light switch	VDE (REG.-Nr. E788) ¹	UL File No. E234324	CCC EAC
02541.3-10	02541.3-11	02541.3-13	AC 100 – 240 V, 50/60 Hz (min. AC 90 V, max. AC 265 V) DC 90 – 110 V (min. DC 80 V, max. DC 125 V)	PIR movement sensor ²	VDE (REG.-Nr. E788) ¹	UL File No. E234324	CCC EAC
02542.3-10	02542.3-11	02542.3-13	AC 100 – 240 V, 50/60 Hz (min. AC 90 V, max. AC 265 V) DC 90 – 110 V (min. DC 80 V, max. DC 125 V)	N/A	VDE (REG.-Nr. E788) ¹	UL File No. E234324	CCC EAC
02540.1-10	02540.1-11	02540.1-13	DC 24 – 48 V (min. DC 20 V, max. DC 60 V)	on/off light switch	VDE (REG.-Nr. E788) ¹	UL File No. E234324	CCC EAC
02541.1-10	02541.1-11	02541.1-13	DC 24 – 48 V (min. DC 20 V, max. DC 60 V)	PIR movement sensor ²	VDE (REG.-Nr. E788) ¹	UL File No. E234324	CCC EAC
02542.1-10	02542.1-11	02542.1-13	DC 24 – 48 V (min. DC 20 V, max. DC 60 V)	N/A	VDE (REG.-Nr. E788) ¹	UL File No. E234324	CCC EAC

¹ VDE Certificate of Conformity (REG.-Nr. E788); ² approx. 5 min. fixed switch-on duration
Note: The lamp must not be used for household lighting.

LAMP

LED 025



- > Wide voltage range
- > Integrated power unit
- > Long-lived and maintenance-free by LED technology
- > Daisy chain
- > On/off switch or movement sensor
- > Magnet, screw or clip fixing

The lamp series LED 025 is suitable for all types of panels and enclosures, especially where space is at a premium. The lamps have a very long service life thanks to the use of LED technology. Three different fixing options provide more flexibility for installation. The power output allows up to 10 lamps to be connected to each other (DC 12 V versions up to 5 lamps). Both the power input and output connectors snap lock into their sockets. With the integrated power unit and the plugs the lamp can quickly be connected.



TECHNICAL DATA

Power consumption	max. 5 W
Luminous flux	400 Lm at 120°
Lamp type	LED, angle of radiation 120° light color: daylight, color temperature: 6,000 K to 7,000 K
Service life	60,000 h at +20 °C (+68 °F)
Connection	2-pole connector with snap lock AC: max. 2.5 A / AC 240 V, color: white DC: max. 2.5 A / DC 60 V, color: blue
Mounting	magnet fixing or screw fixing (M5), clip fixing (M6), torque 2 Nm max.
Casing	plastic, transparent
Dimensions	see drawings
Weight	0.2 kg
Operating/Storage temperature	-30 to +60 °C (-22 to +140 °F) / -40 to +85 °C (-40 to +185 °F)
Operating/Storage humidity	max. 90 % RH (non-condensing)
Protection type/Protection class	IP20 / II (double insulated), DC 12 V: IP20 / III (extra-low voltage)

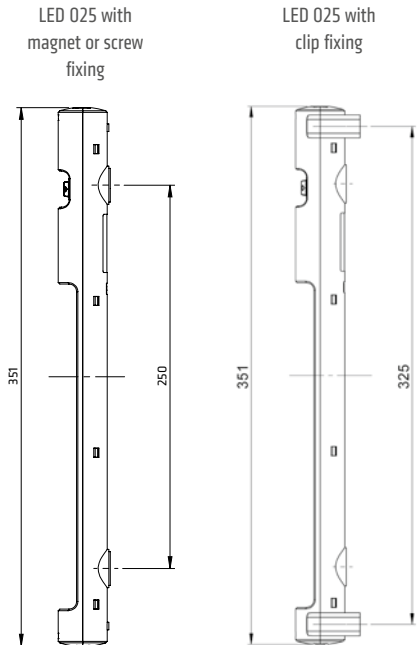

Mounting options: The lamps are available with magnet fixing for easy positioning in any steel cabinet or enclosure. A classic is the LED 025 with screw fixing. The clip holders exclusively designed for clip fixing of the LED 025 can be positioned anywhere in the cabinet by simply screwing the holders to the cabinet wall. The lamp is snapped into the clip holders and can be turned in both directions. With a total rotation angle of 180° it provides perfect illumination within the cabinet or enclosure.

Note: The lamp must not be used for household lighting.

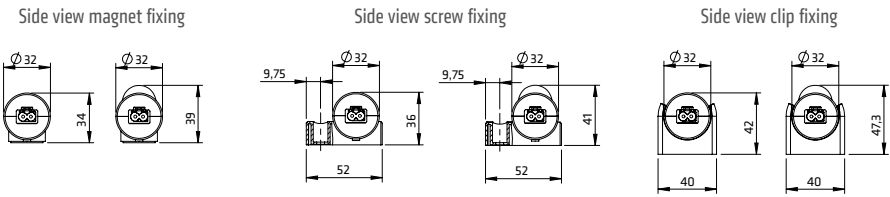

Art. No. Magnet fixing	Art. No. Screw fixing	Art. No. Clip fixing	Operating voltage	Switch	Approvals			
02540.0-00	02540.0-01	02540.0-03	AC 100 – 240 V, 50/60 Hz (min. AC 90 V, max. AC 265 V)	on/off light switch	VDE	UL File No. E234324	CCC	EAC
02540.1-00	02540.1-01	02540.1-03	DC 24 – 48 V (min. DC 20 V, max. DC 60 V)	on/off light switch	VDE	UL File No. E234324	CCC	EAC
02540.2-00	02540.2-01	02540.2-03	DC 12 V (min. DC 10 V, max. DC 16 V)	on/off light switch	-	UL File No. E234324	-	EAC
02541.0-00	02541.0-01	02541.0-03	AC 100 – 240 V, 50/60 Hz (min. AC 90 V, max. AC 265 V)	PIR movement sensor ¹	VDE	UL File No. E234324	CCC	EAC
02541.1-00	02541.1-01	02541.1-03	DC 24 – 48 V (min. DC 20 V, max. DC 60 V)	PIR movement sensor ¹	VDE	UL File No. E234324	CCC	EAC

¹ approx. 5 min. fixed switch-on duration

ACCESSORIES

Connectors and cables for electrical connection are not included in the delivery of the LED O25. These parts can be ordered separately. Sets, consisting of lamp and accessories, are available on request.

CONNECTION CABLE WITH FEMALE CONNECTOR AND OPEN END



Photo: Connection cable, Art. No. 244356

Art. No.	Model	Length	Voltage type	Color	Use for	Approvals ²
244356	connection cable 2 x 1.5 mm ² with female connector	2.0 m	AC	connector: white; cable: white	power input	VDE
244357	connection cable 2 x AWG 16 with female connector	2.0 m	AC	connector: white; cable: white	power input	VDE + UL
244360	connection cable 2 x 0.75 mm ² with female connector	2.0 m	DC 24 – 48 V	connector: blue; cable: white	power input	VDE
244361	connection cable 2 x AWG 16 with female connector	2.0 m	DC 24 – 48 V	connector: blue; cable: white	power input	VDE + UL
244389	connection cable 2 x 0.75 mm ² with female connector	2.0 m	DC 12 V	connector: blue; cable: white	power input	VDE
244390	connection cable 2 x AWG 16 with female connector	2.0 m	DC 12 V	connector: blue; cable: white	power input	VDE + UL

² applies only to the individual components (cable and connectors)

EXTENSION CABLE WITH 2 CONNECTORS FOR DAISY CHAIN CONNECTION



Photo: Extension cable, Art. No. 244358

Art. No.	Model	Length	Voltage type	Color	Use for	Approvals ²
244358	extension cable 2 x 1.5 mm ² with 2 connectors	1.0 m	AC	connectors: white; cable: white	daisy chain	VDE
244359	extension cable 2 x AWG 16 with 2 connectors	1.0 m	AC	connectors: white; cable: white	daisy chain	VDE + UL
244362	extension cable 2 x 1.5 mm ² with 2 connectors	1.0 m	DC 24 – 48 V	connectors: blue; cable: white	daisy chain	VDE
244363	extension cable 2 x AWG 16 with 2 connectors	1.0 m	DC 24 – 48 V	connectors: blue; cable: white	daisy chain	VDE + UL
244391	extension cable 2 x 1.5 mm ² with 2 connectors	1.0 m	DC 12 V	connectors: blue; cable: white	daisy chain	VDE
244392	extension cable 2 x AWG 16 with 2 connectors	1.0 m	DC 12 V	connectors: blue; cable: white	daisy chain	VDE + UL

² applies only to the individual components (cable and connectors)

FEMALE / MALE CONNECTORS



Photo: Female connector, Art. No. 264057

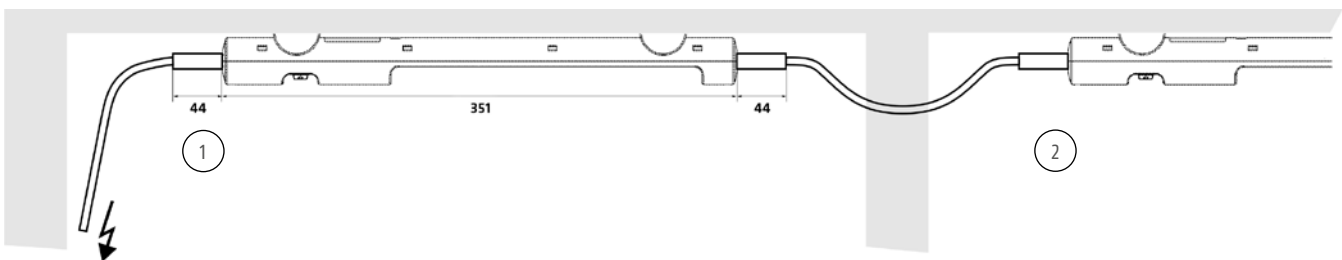

Photo: Male connector, Art. No. 264058

Art. No.	Model	Voltage type	Color	Use for	Wire cross-section ³	Approvals
264057	female connector	AC	white	power input	0.5-2.5 mm ² (AWG 14-20)	VDE + UL
264058	male connector	AC	white	power output	0.5-2.5 mm ² (AWG 14-20)	VDE + UL
264059	female connector	DC 24 – 48 V	blue	power input	0.5-2.5 mm ² (AWG 14-20)	VDE + UL
264060	male connector	DC 24 – 48 V	blue	power output	0.5-2.5 mm ² (AWG 14-20)	VDE + UL
264065	female connector	DC 12 V	blue	power input	0.5-2.5 mm ² (AWG 14-20)	VDE + UL
264066	male connector	DC 12 V	blue	power output	0.5-2.5 mm ² (AWG 14-20)	VDE + UL

³ applies to rigid and stranded wire. Wire end ferrules must be used when connecting with stranded wires.

CONNECTION EXAMPLE



This illustration shows the LED O25 lamp in a daisy chain application. The lamps are conveniently connected via quick connection plugs – up to 10 (5) lamps max. can be daisy-chained this way. The snap lock connectors ensure a stable electrical connection even if subjected to heavy vibration. The connection example shows a AC 230 V application, using the following cables: connection cable with female connector, Art. No. 244356 (1); daisy chain extension cable with 2 connectors, Art. No. 244358 (2).

Female/male connectors are also available to assemble cables in non-standard lengths.

SLIMLINE LAMP WITH ON/OFF SWITCH

SL 025



- > Slim casing
- > Electronic ballast
- > Lamp without/with electrical socket (choice of sockets)
- > Magnet fixing (option)
- > Energy saving lamp
- > On/Off switch

The flat slimline lamp SL 025 is suitable for all types of panels and enclosures, especially where space is at a premium. The lamp can be mounted on its narrow or broad surface using screws. It is also available with a magnet which allows it to be fitted quickly in any position in a steel enclosure. Both versions are available with an integrated electrical socket enabling the use of additional appliances.

Photo: Slimline lamp with on/off switch, with integrated electric socket (Germany), Art. No. 02520.0-00



TECHNICAL DATA

Power consumption	11 W
Luminosity	900 Lm (equals 75 W light bulb)
Lamp type	energy saving lamp, 2G7 socket
Service life	10,000 h
Switch	on/off light switch
Connection	terminal 2.5 mm ² with cable clamp, torque 0.8 Nm max.
Mounting	screw fixing, M5, 300 mm centers magnet fixing (optional)
Casing	plastic according to UL94 V-0, light grey
Dimensions	345 x 91 x 40 mm
Fitting position	narrow surface/broad surface
Operating/Storage temperature	-20 to +50 °C (-4 to +122 °F) / -45 to +70 °C (-49 to +158 °F)
Operating/Storage humidity	max. 90 % RH (non-condensing)
Protection type	IP20

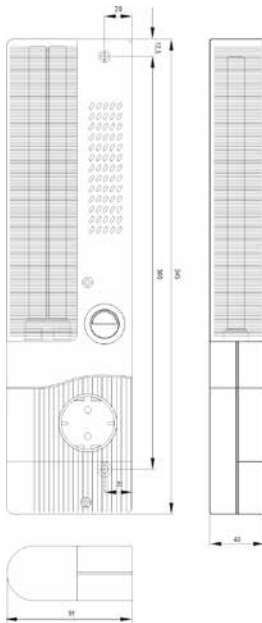

Art. No.	Model	Operating voltage	Socket	Nominal current	Weight (approx.)	Protection class	Approvals		
02520.0-00	without magnet	AC 230 V, 50/60 Hz	Germany/Russia (1)	16.0 A	0.4 kg	I (earthed)	VDE	-	EAC
02520.1-01	with magnet	AC 230 V, 50/60 Hz	Germany/Russia (1)	16.0 A	0.5 kg	I (earthed)	VDE	-	EAC
02521.0-00	without magnet	AC 230 V, 50/60 Hz	F/PL/CZ/SK (2)	16.0 A	0.4 kg	I (earthed)	VDE	-	EAC
02521.1-04	with magnet	AC 230 V, 50/60 Hz	F/PL/CZ/SK (2)	16.0 A	0.5 kg	I (earthed)	VDE	-	EAC
02522.0-00	without magnet	AC 230 V, 50/60 Hz	Switzerland (3)	10.0 A	0.4 kg	I (earthed)	VDE	-	EAC
02522.1-01	with magnet	AC 230 V, 50/60 Hz	Switzerland (3)	10.0 A	0.5 kg	I (earthed)	VDE	-	EAC
02523.0-00	without magnet	AC 230 V, 50/60 Hz	UK/Ireland (4)	13.0 A	0.4 kg	I (earthed)	VDE	-	EAC
02523.1-05	with magnet	AC 230 V, 50/60 Hz	UK/Ireland (4)	13.0 A	0.5 kg	I (earthed)	VDE	-	EAC
02524.0-01	without magnet	AC 120 V, 50/60 Hz	USA/Canada (5)	15.0 A	0.4 kg	I (earthed)	-	UL File No. E234324	EAC
02524.1-05	with magnet	AC 120 V, 50/60 Hz	USA/Canada (5)	15.0 A	0.5 kg	I (earthed)	-	UL File No. E234324	EAC
02527.0-00	without magnet	AC 230 V, 50/60 Hz	none	-	0.4 kg	II (double insulated)	VDE	UL File No. E234324	EAC
02527.1-14	with magnet	AC 230 V, 50/60 Hz	none	-	0.5 kg	II (double insulated)	VDE	-	EAC
02527.0-10	without magnet	AC 120 V, 50/60 Hz	none	-	0.4 kg	II (double insulated)	-	UL File No. E234324	EAC
02527.1-11	with magnet	AC 120 V, 50/60 Hz	none	-	0.5 kg	II (double insulated)	-	UL File No. E234324	EAC
02525.0-00	without magnet	DC 24 – 48 V	none	-	0.4 kg	II (double insulated)	VDE	UL File No. E234324	EAC
02525.1-01	with magnet	DC 24 – 48 V	none	-	0.5 kg	II (double insulated)	VDE	UL File No. E234324	EAC

Note: The slimline lamp SL 025 is also available with a 19" front panel.

SLIMLINE LAMP WITH MOVEMENT SENSOR

SL 025



Photo: Slimline lamp with movement sensor and with integrated electric socket (Germany), Art. No. 02520.0-03

- > Slim casing
- > Electronic ballast
- > Lamp without/with electrical socket (choice of sockets)
- > Magnet fixing (option)
- > Energy saving lamp
- > Automatic switching

The flat slimline lamp SL 025 with movement sensor is suitable for all types of panels and enclosures, especially where space is at a premium. The lamp can be mounted on its narrow or broad surface using screws. It is also available with a magnet which allows it to be fitted quickly in any position in a steel enclosure. Both versions are available with an integrated electrical socket enabling the use of additional appliances. The movement sensor substitutes a door contact switch.



TECHNICAL DATA

Power consumption	11 W
Luminosity	900 Lm (equals 75 W light bulb)
Lamp type	energy saving lamp, 2G7 socket
Service life	10,000 h
Switch	PIR movement sensor, approx. 6 min. fixed switch-on duration
Connection	terminal 2.5 mm ² with cable clamp, torque 0.8 Nm max.
Mounting	screw fixing, M5, 300 mm centers, magnet fixing (optional)
Casing	plastic according to UL94 V-0, light grey
Dimensions	345 x 91 x 40 mm
Fitting position	narrow surface/broad surface
Operating/Storage temperature	-20 to +50 °C (-4 to +122 °F) / -45 to +70 °C (-49 to +158 °F)
Operating/Storage humidity	max. 90 % RH (non-condensing)
Protection type	IP20

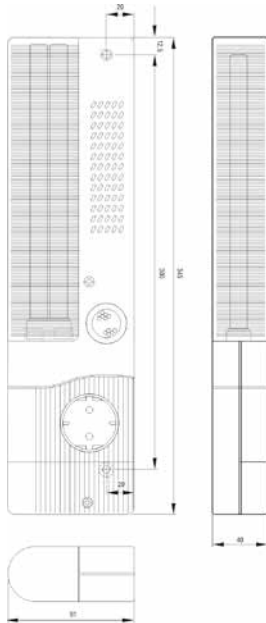

The PIR movement sensor switches the lighting on when the enclosure door is opened. The switch-on time is reset with every further registered movement. The movement sensor does not react to movement on the other side of glass and so can be used in enclosures with glass doors.



Art. No.	Model	Operating voltage	Socket	Nominal current	Weight (approx.)	Protection class	Approvals
02520.0-03	without magnet	AC 230 V, 50/60 Hz	Germany/Russia (1)	16.0 A	0.4 kg	I (earthed)	VDE - EAC
02520.1-04	with magnet	AC 230 V, 50/60 Hz	Germany/Russia (1)	16.0 A	0.5 kg	I (earthed)	VDE - EAC
02521.0-03	without magnet	AC 230 V, 50/60 Hz	F/PL/CZ/SK (2)	16.0 A	0.4 kg	I (earthed)	VDE - EAC
02521.1-05	with magnet	AC 230 V, 50/60 Hz	F/PL/CZ/SK (2)	16.0 A	0.5 kg	I (earthed)	VDE - EAC
02522.0-03	without magnet	AC 230 V, 50/60 Hz	Switzerland (3)	10.0 A	0.4 kg	I (earthed)	VDE - EAC
02522.1-04	with magnet	AC 230 V, 50/60 Hz	Switzerland (3)	10.0 A	0.5 kg	I (earthed)	VDE - EAC
02523.0-03	without magnet	AC 230 V, 50/60 Hz	UK/Ireland (4)	13.0 A	0.4 kg	I (earthed)	VDE - EAC
02523.1-04	with magnet	AC 230 V, 50/60 Hz	UK/Ireland (4)	13.0 A	0.5 kg	I (earthed)	VDE - EAC
02524.0-04	without magnet	AC 120 V, 50/60 Hz	USA/Canada (5)	15.0 A	0.4 kg	I (earthed)	- UL File No. E234324 EAC
02524.1-06	with magnet	AC 120 V, 50/60 Hz	USA/Canada (5)	15.0 A	0.5 kg	I (earthed)	- UL File No. E234324 EAC
02527.0-04	without magnet	AC 230 V, 50/60 Hz	none	-	0.4 kg	II (double insulated)	VDE UL File No. E234324 EAC
02527.1-15	with magnet	AC 230 V, 50/60 Hz	none	-	0.5 kg	II (double insulated)	VDE - EAC
02527.0-12	without magnet	AC 120 V, 50/60 Hz	none	-	0.4 kg	II (double insulated)	- UL File No. E234324 EAC
02527.1-17	with magnet	AC 120 V, 50/60 Hz	none	-	0.5 kg	II (double insulated)	- UL File No. E234324 EAC

Note: The slimline lamp SL 025 is also available with a 19" front panel.

COMPACT LAMP

KL 025



Lamp shown with protective plastic cover (see Accessories)

- > Magnetic or optional DIN rail mounting
- > Energy-saving lamp
- > Lamp without/with electrical socket (choice of sockets)
- > On/Off switch

The compact lamp KL 025 was especially designed for use in enclosures with electric/electronic components. A powerful magnet enables the lamp to be mounted freely in any desired position in metal enclosures saving time and installation problems. The integrated electrical socket allows the use of additional appliances.



TECHNICAL DATA

Luminosity	900 Lm (equals light bulb 75 W / AC 230 V, 60 W / AC 120 V)
Lamp type	compact fluorescent lamp with integral starter
Service life	5,000 h
Switch	on/off light switch
Connection	3-pole terminal 2.5 mm ² with cable clamp, torque 0.8 Nm max.
Mounting	magnet fixing
Casing	plastic, light grey
Dimensions	355 x 65 x 70 mm
Weight	approx. 1 kg
Fitting position	variable
Operating/Storage temperature	-20 to +50 °C (-4 to +122 °F) / -45 to +70 °C (-49 to +158 °F)
Operating/Storage humidity	max. 90 % RH (non-condensing)
Protection type	IP20
Accessories	lamp cover, Art. No. 09520.0-00 (see photo)

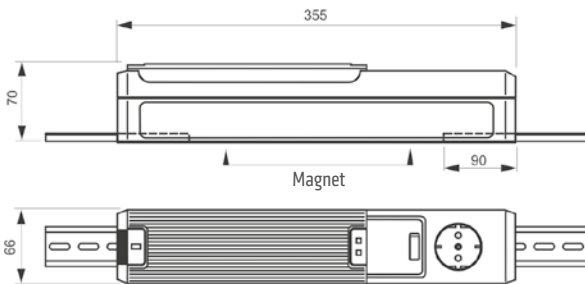

In plastic, aluminium or stainless steel cabinets the lamp can be fixed using screws together with inserted 35 mm DIN rail sections.

Art. No.	Operating voltage	Socket	Power consumption	Nominal current	Protection type	Approvals
02500.0-00	AC 230 V, 50 Hz	Germany/Russia (1)	11 W	16.0 A	I (earthed)	VDE EAC
02500.0-07	AC 230 V, 50 Hz	none	11 W	-	II (double insulated)	- EAC
02501.0-00	AC 230 V, 50 Hz	F/PL/CZ/SK (2)	11 W	16.0 A	I (earthed)	- EAC
02502.0-00	AC 230 V, 50 Hz	Switzerland (3)	11 W	10.0 A	I (earthed)	- EAC
02510.0-00	AC 230 V, 50 Hz	UK/Ireland (4)	11 W	13.0 A	I (earthed)	- EAC
02512.0-00	AC 230 V, 50 Hz	Italy (6)	11 W	16.0 A	I (earthed)	- EAC
02505.9-00	AC 120 V, 60 Hz	USA/Canada (5)	9 W	15.0 A	I (earthed)	- EAC
02505.9-01	AC 120 V, 60 Hz	none	9 W	-	II (double insulated)	- EAC



ACCESSORIES

COMPLEMENTARY ELECTRONICS PROTECTION

Accessory products from STEGO expand the climatization portfolio appropriately and offer more specific solutions for individual needs.

ELECTRICAL SOCKET

SD 035



> Quickly connected
> Available with or without fuse

> Clip fixing

The DIN rail mounted electrical socket can be quickly fitted and connected in enclosures allowing the use of auxiliary products such as hand lamps, measuring devices, soldering irons etc. The unit is available with and without fuse and in many world socket standards.



TECHNICAL DATA

Connection	3 x pressure clamps for stranded and rigid wire 0.5 – 2.5 mm ²
Mounting	clip for 35 mm DIN rail, EN 60715
Casing	plastic according to UL94 V-0, light grey
Dimensions	92 x 62 x 48 mm
Weight	approx. 0.2 kg
Fitting position	variable
Operating/Storage temperature	-45 to +70 °C (-49 to +158 °F)
Operating/Storage humidity	max. 90 % RH (non-condensing)
Protection type/Protection class	IP20 / I (earthed)

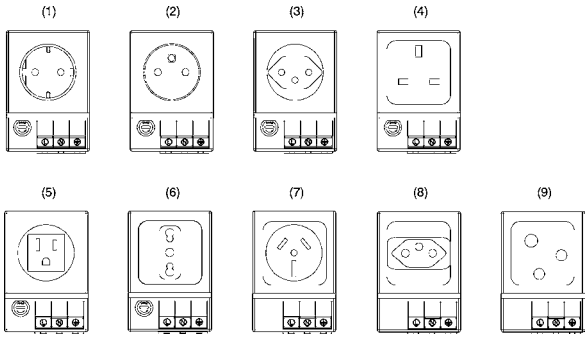
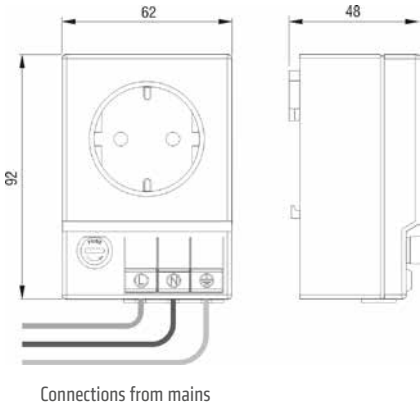

Art. No.	Operating voltage max.	Socket	Model	Nominal current	Approvals
03500.0-00	AC 250 V	Germany/Russia (1)	with fuse ¹	6.3 A	EAC
03500.0-01	AC 250 V	Germany/Russia (1)	without fuse	16.0 A	EAC
03501.0-00	AC 250 V	F/PL/CZ/SK (2)	with fuse ¹	6.3 A	-
03501.0-01	AC 250 V	F/PL/CZ/SK (2)	without fuse	16.0 A	-
03502.0-00	AC 250 V	Switzerland (3)	with fuse ¹	6.3 A	-
03502.0-01	AC 250 V	Switzerland (3)	without fuse	10.0 A	-
03503.0-00	AC 250 V	UK/Ireland (4)	with fuse ¹	6.3 A	-
03503.0-01	AC 250 V	UK/Ireland (4)	without fuse	13.0 A	-
03504.0-00	AC 125 V	USA/Canada (5)	with fuse ¹	6.3 A	UL File No. E222026
03504.0-01	AC 125 V	USA/Canada (5)	without fuse	15.0 A	UL File No. E222026
03505.0-00	AC 250 V	Italy (6)	with fuse ¹	6.3 A	-
03505.0-01	AC 250 V	Italy (6)	without fuse	16.0 A	-
03507.0-01	AC 240 V	Australia (7)	without fuse	10.0 A	-
03508.0-01	AC 250 V	Brazil (8)	without fuse	10.0 A	-
03509.0-01	AC 250 V	Old British – BS 546 (9)	without fuse	5.0 A	-

¹ fuse Ø 5 x 20 mm

PRESSURE COMPENSATION DEVICE

DA 084 | IP55



Photo: Inside view

> High degree of protection > Easy to install

It has become more and more important to provide a protected enclosure environment for valuable and crucial electrical and electronic components. In a tightly closed enclosure, pressure differentials can occur during extreme temperature variations. The specially designed pressure compensation device DA 084 permits a controlled change in pressure and avoids the entering of dust and water. The pressure compensation device is suitable for the use in enclosures and housings in accordance with DIN EN 62208.



TECHNICAL DATA

Mounting	PG 29 thread with union nut
Torque	5 Nm
Material	plastic according to UL94 V-0, light grey weather proof and UV light resistant according to UL746C (f1)
Sealing	sealing gasket NBR
Air interface	approx. 1.5 cm ²
Dimensions	Ø 65,5 x 30,5 mm
Fitting position	vertical ¹
Operating/Storage temperature	-45 to +70 °C (-49 to +158 °F)
Approvals	EAC
Note	Material adheres to limit values in accordance with RoHS3

¹ Protection type is restricted to IP54 if fitting position of DA 084 is not vertical.

Installation: Make cut-out Ø 37¹ mm in enclosure wall and mount pressure compensation device with nut. Please make sure that the sealing gasket is put in place on the outer side panel of the enclosure. For optimal pressure compensation we recommend to use two devices on opposite sides towards the top of the enclosure.

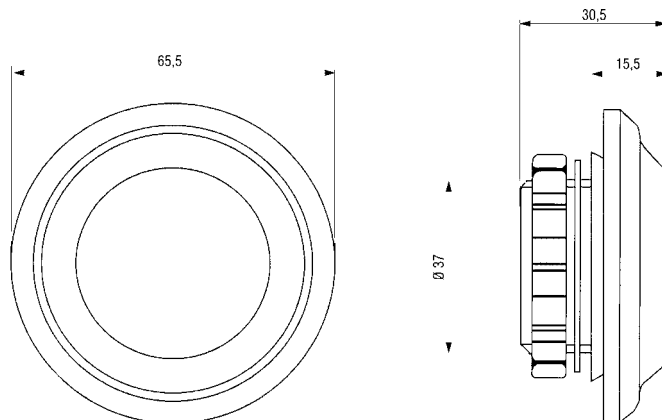

Art. No.	Protection type	1 packing unit	Weight (approx.)
08400.0-03	IP55	2 pieces	62 g (31 g / piece)

PRESSURE COMPENSATION DEVICE

DA 284 | IP66 / IP67



Photo: DA 284, M40



Photo: DA 284, M12

- > High degree of protection
- > Waterproof membrane

- > Easy to install

Pressure differentials in enclosures with a high degree of protection are a result of internal and external temperature changes. In the case of negative pressure or partial vacuum, dust and humidity can enter the enclosure through the door seal. When the air inside the enclosure cools down, condensation may occur because the humidity cannot escape the enclosure. The easy-to-install pressure compensation device DA 284 provides compensation of pressure at a protection degree of IP66 (M12: IP67). Even with a slight overpressure, a waterproof membrane inside the plug allows the humidity to escape whilst blocking water and dirt from entering the enclosure.



TECHNICAL DATA

Mounting	thread M40 x 1.5 or M12 x 1.5 with nut
Torque	M40: 5 Nm, M12: 0.5 Nm
Depth in enclosure	M40: approx. 16mm, M12: approx. 8 mm
Sealing	sealing gasket NBR
Filter	waterproof membrane
Dimensions	M40: Ø 60 x 37 mm, M12: Ø 17 x 17.5 mm
Fitting position	variable
Note	Material adheres to limit values in accordance with RoHS3

Installation: Make cut-out Ø 40.5^{+0.5} mm in enclosure wall for size M40 or Ø 12^{+0.2} mm for size M12, and mount pressure compensation device with nut. Please make sure that the sealing gasket is put in place on the outer side panel of the enclosure. For optimal pressure compensation we recommend to use two devices on opposite sides towards the top of the enclosure.

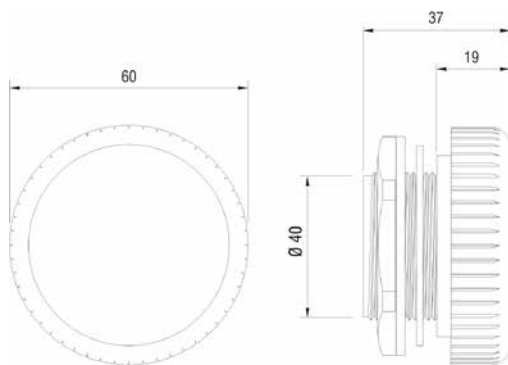

DA 284, M40

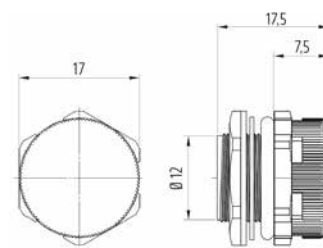

DA 284, M12 (drawing is not proportional to M40)

Art. No.	Thread	Material	Protection type	Air permeability ¹	Operating/Storage temperature	1 packing unit	Weight (approx.)	Approvals
28400.0-00	M40 x 1.5	plastic, light grey	IP66 (EN 60529) / IPX9K (EN 40050-9)	1,200 l/h	-35 to +70 °C (-31 to +158 °F)	2 pieces	90 g (45 g / piece)	- EAC
28400.0-01	M40 x 1.5	plastic, light grey	IP66 (EN 60529) / IPX9K (EN 40050-9)	1,200 l/h	-35 to +70 °C (-31 to +158 °F)	1 piece	45 g	- EAC
28400.0-04	M40 x 1.5	plastic, light grey	IP66 (EN 60529) / IPX9K (EN 40050-9)	1,200 l/h	-35 bis +70 °C (-31 bis +158 °F)	100 pieces	4.5 kg (45 g / piece)	- EAC
28405.0-00	M40 x 1.5	plastic according to UL94 V-0, light grey; weather proof and UV light resistant according to UL746C (f1)	IP66 (EN 60529) / IPX9K (EN 40050-9)	1,200 l/h	-45 to +70 °C (-49 to +158 °F)	2 pieces	120 g (60 g / piece)	UL File No. E234324 EAC
28406.0-00	M12 x 1.5	plastic according to UL94 V-0, light grey; weather proof and UV light resistant according to UL746C (f1)	IP67 (EN 60529) / IPX9K (EN 40050-9)	120 l/h	-40 to +70 °C (-40 to +158 °F)	2 pieces	4 g (2 g / piece)	UL File No. E234324 EAC

¹ at a pressure difference of min. 70 mbar

PRESSURE COMPENSATION DEVICE (STAINLESS STEEL)

DA 284 | IP66



Photo: Inside view

- > High degree of protection
 - > Waterproof membrane
- > Corrosion resistant
 - > Food safe

Pressure differentials in enclosures with a high degree of protection are a result of internal and external temperature changes. In the case of negative pressure or partial vacuum, dust and humidity can enter the enclosure through the door seal. When the air inside the enclosure cools down, condensation may occur because the humidity cannot escape the enclosure. The easy-to-install pressure compensation device DA 284 provides compensation of pressure at a protection degree of IP66. Even with a slight overpressure, a waterproof membrane inside the plug allows the humidity to escape whilst blocking water and dirt from entering the enclosure.



TECHNICAL DATA

Mounting	thread M40 x 1.5 with nut
Torque	5 Nm
Depth in enclosure	approx. 9 mm
Sealing	sealing gasket NBR
Filter	waterproof membrane
Air permeability	1,200 l/h at a pressure difference of min. 70mbar
Dimensions	Ø 58 x 31 mm
Fitting position	variable
Operating/Storage temperature	-45 to +80 °C (-49 to +176 °F)
Approvals	EAC
Note	Material adheres to limit values in accordance with RoHS3

Installation: Make cut-out Ø 40.5^{+0.5} mm in enclosure wall and mount pressure compensation device with nut. Please make sure that the sealing gasket is put in place on the outer side panel of the enclosure. For optimal pressure compensation we recommend to use two devices on opposite sides towards the top of the enclosure.

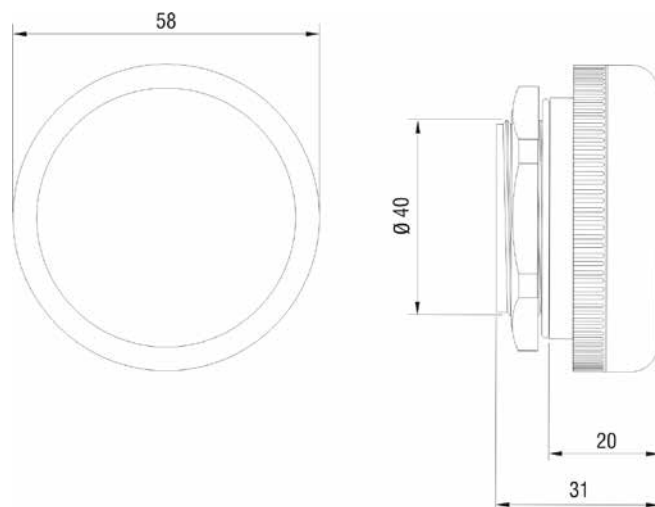

Art. No.	Stainless steel	Protection type	1 packaging unit	Weight (approx.)
28401.0-00	V2A (DIN 1.4305 / AISI 303) ¹	IP66 (EN 60529) / IPX9K (EN 40050-9)	1 piece	0.2 kg
28401.0-02	V4A (DIN 1.4404 / AISI 316L)	IP66 (EN 60529) / IPX9K (EN 40050-9)	1 piece	0.2 kg

¹V2A is not sea waterproof

VENTILATION CABLE GLAND

DAK 284 | IP66 / IP67



- > Cable gland with integrated ventilation
- > High degree of protection
- > Easy to install
- > Integrated strain relief
- > Waterproof filter
- > Large clamping range

Pressure differentials in enclosures with a high degree of protection are a result of internal and external temperature changes. In the case of negative pressure or partial vacuum, dust and humidity can enter the enclosure through the door seal. When the air inside the enclosure cools down, condensation may occur because the humidity cannot escape the enclosure. The innovative and easy-to-install ventilation cable gland DAK 284 enables secure cable entry into an enclosure with simultaneous pressure compensation (protection type IP66 / IP67). Even with a slight overpressure, a waterproof filter inside the gland allows the humidity to escape whilst blocking water and dirt from entering the enclosure.



TECHNICAL DATA

Mounting	thread M12 x 1.5 / M16 x 1.5 / M20 x 1.5
Enclosure wall thickness	0.5 – 3 mm with lock nut
Material	plastic, light grey
Protection type	IP66 / IP67 (EN 60529)
Sealing	sealing gasket NBR
Filter	PTFE
Fitting position	variable
Operating/Storage temperature	-20 to +80 °C (-4 to +176 °F)
Approvals	VDE, UL File No. E471430, EAC

Installation: Make cut-out in enclosure wall and mount ventilation cable gland with lock nut. Please make sure that the sealing gasket is put in place on the outer side panel of the enclosure and the hole is free of burrs.

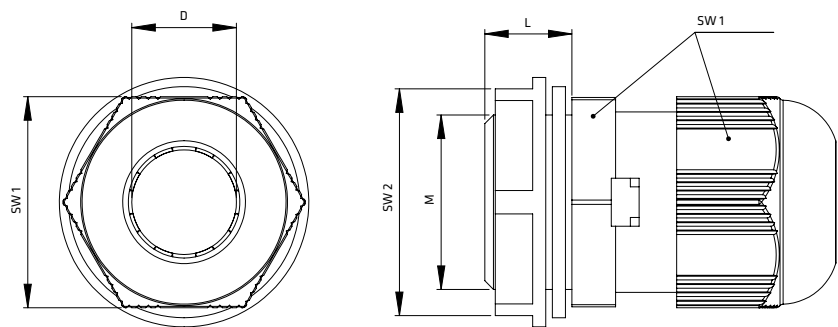

Art. No.	Thread		Diameter	Clamping range D	Spanner sizes [mm]		Torque		Air permeability ¹	Weight
	Size M [mm]	Length L			SW 1	SW 2	Lock nut	Cap nut		
28410.0-00	M12 x 1.5	8 mm	12.3 mm	4 – 8 mm	19	18	2 Nm	2 Nm	25 l/h	7 g
28411.0-00	M16 x 1.5	10 mm	16.3 mm	4 – 8 mm	19	22	2 Nm	2 Nm	25 l/h	8 g
28412.0-00	M20 x 1.5	10 mm	20.3 mm	6 – 12 mm	24	26	5 Nm	5 Nm	40 l/h	13 g

¹ at a pressure differential of 70 mbar

DRAINAGE DEVICE

DD 084 | IP66 / IP67 / IP69K



Photo: Inside view

- > High degree of protection
- > Good drainage performance
- > Easy to install

- > Robust, weather and UV-light protected housing

Condensate occurs in enclosures and housings with high protection type by variations in temperature. The use of a drainage device allows the conveying of the condensate without losing the maximum protection type of IP66. The water permeable membrane makes sure the drainage of the enclosure by the capillary attraction. The construction prevents the infiltration of splash water into the enclosure.



TECHNICAL DATA

Mounting	thread M50 x 1.5 with nut (wrench size 60 mm, housing 50 mm)
Torque	6 Nm max.
Depth in enclosure	max. 17.5 mm
Material	plastic according to UL94 V-0, umbra grey, weather proof and UV light resistant according UL746C (f1)
Water entry height	0 mm (at 0.5 mm wall thickness)
Sealing	sealing gasket NBR
Water flow-through	approx. 200 ml/h at a water column of 5 mm
Dimensions	Ø 60 x 49.5 mm
Fitting position	horizontal, lowest point
Operating/Storage temperature	-45 to +70 °C (-49 to +158 °F)
Approvals	EAC
Note	Material adheres to limit values in accordance with RoHS3

Installation: Make cut-out Ø 50.5^{+0.5} mm in enclosure bottom and mount drainage device with nut. Please make sure that the sealing gasket is put in place on the outer side panel of the enclosure and the hole is free of burrs.

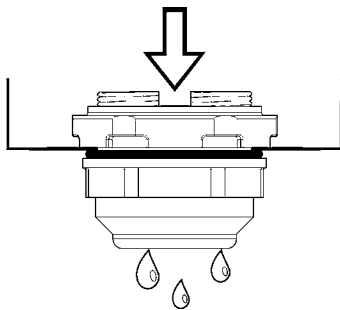

Fitting position

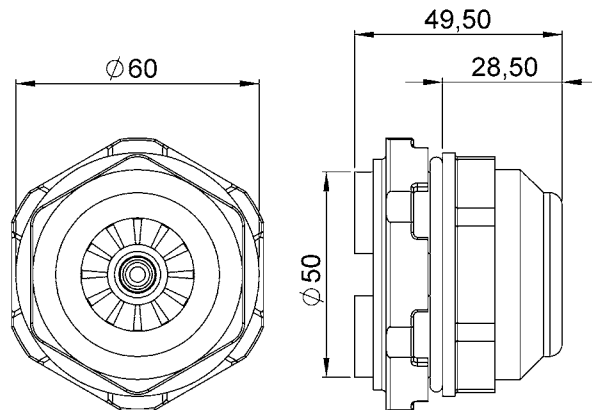

Art. No.	Protection type	Enclosure wall thickness	1 package unit	Weight (approx.)
08410.0-00	IP66 / IP67 (EN 60529) / IP69K (EN 40050-9)	0.5 - 5.5 mm	1 piece	60 g

DOOR SWITCH

DS 013



- > Adjustable positioning without tools
- > High switching capacity
- > Strain relief
- > Different cladding diameters
- > Suitable for lamp LED 025

The door switch monitors the position of cabinet doors and is available in three versions. For example, it can be used for switching a light when opening a door (NC), or to activate a fan when closing a door (NO). The version with change-over contact (CO) can be used as a normally closed and/or normally open contact. The wide mechanical adjustment range of the door switch DS 013 offers versatile application areas: the housing is adjustable within a 35 mm range, while the screw flange with a slotted hole offers an additional 21 mm. The switching travel of the switch itself is another 8 mm.



TECHNICAL DATA

Max. switching capacity	AC 250 V, 8 (1.5) A
Service life	VDE: > 10,000 cycles UL: > 6,000 cycles
Connection	4-pole clamp with strain relief, clamping torque 0.5 Nm max.
Mounting	screw fixing (M5)
Casing	plastic according to UL94 V-0, grey/black
Dimensions	87 x 64 x 30 mm
Weight	approx. 50 g
Fitting position	variable
Operating/Storage temperature	-20 to +85 °C (-4 to +185 °F)
Operating/Storage humidity	max. 90 % RH (non-condensing)
Protection type	IP20
Approvals	VDE, EAC; UL intended

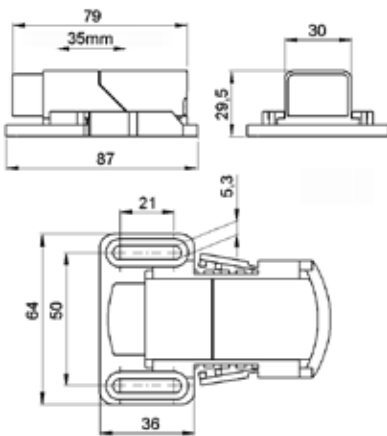

Connection diagrams

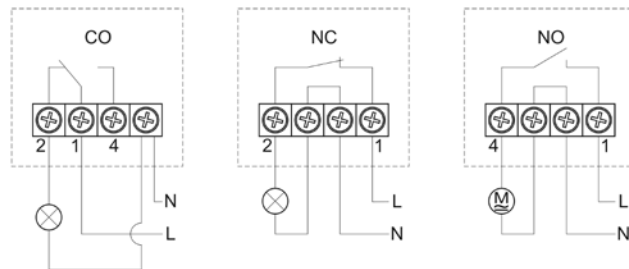

Art. No.	Model	Suitable wire
01350.0-00	change-over (CO)	Cable round, stranded wire (with wire end ferrule) 0.75 mm ² to 1 mm ²
01351.0-00	normally closed (NC)	Cable round, stranded wire (with wire end ferrule) 0.75 mm ² to 1.5 mm ²
01352.0-00	normally open (NO)	Cable round, stranded wire (with wire end ferrule) 0.75 mm ² to 1.5 mm ²

APPLIANCE HOLDER STEGOFIX PLUS

SFP 095



Screw mounting



Self-adhesive tape mounting



Magnet mounting



Application example

- > Alternative to 35 mm DIN rail
- > Easy/flexible installation
- > For devices and sockets with DIN rail mounting clip
- > Screw mounting
- > Self-adhesive tape mounting
- > Magnet mounting

The appliance holder STEGOFIX PLUS is the flexible alternative to a 35 mm DIN rail. It allows for a quick and easy installation of small devices or accessory equipment intended for DIN rail mounting. STEGOFIX PLUS is suitable for devices with a clip width of max. 66 mm, offering a convenient mounting method for almost any application: screw mounting with 25 mm pitch, high-performance adhesive tape or rubberized neodymium magnets.



TECHNICAL DATA

Areas of application	devices with DIN rail mounting clip suitable for a 35 mm DIN rail according to EN 60715, max. clip width 66 mm
Mounting	
> Screw mounting	e.g. tapping screws DIN 7981 (ISO 7049), Ø 5.5 mm; thread-forming screws DIN 7500, M5; (not included in delivery)
> Self-adhesive tape mounting	adhesive surface 65 x 25 mm
> Magnet mounting	2 neodymium magnets, rubberized
Material	plastic according to UL94 V-0, black
Dimensions	71 x 40 x 15 mm
Operating temperature	-35 to +75 °C (-31 to +167 °F)
Storage conditions (self-adhesive tape)	optimal storage conditions for self-adhesive tape approx. +20 °C (+68 °F) at 50 % RH
Approvals	EAC
Note	Material adheres to limit values in accordance with RoHS3

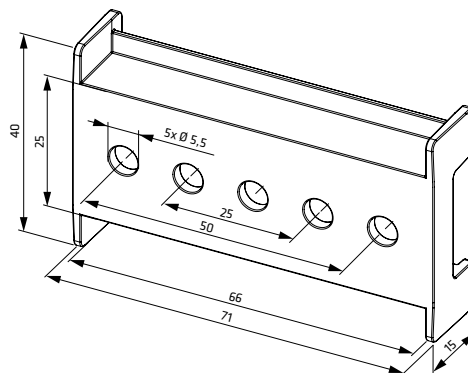

Art. No.	Model	Max. Holding force ¹	1 packing unit	Weight (approx.)
09550.0-05	Screw mounting	-	5 pieces	65 g (13 g / piece)
09550.1-05	Self-adhesive tape mounting	75 N	5 pieces	70 g (14 g / piece)
09550.2-05	Magnet mounting	30 N	5 pieces	145 g (29 g / piece)

¹ At room temperature. Depending on the conditions of use (e.g. surface condition, size of device to be mounted, etc.) the actual holding force may differ from the values specified in the table above.



EX PROTECTION

EXPLOSION PROTECTION EQUIPMENT

Specific requirements apply to the operation of electrical equipment in hazardous areas. STEGO heaters and thermostats meet international and European standards.

HAZARDOUS AREA HEATER

CREX 020 | 50 W to 250 W (T3)



- > For areas with explosion and firedamp hazard
- > Large convection surface
- > Clip and screw flange fixing
- > Ready-to-use with strain relief
- > Maintenance free
- > Temperature class T3

Compact convection heater of temperature class T3 (200 °C max.) for the prevention of formation of condensation, temperature fluctuations, and for protection against frost within control and switch cabinets, as well as measuring equipment located in areas with explosion hazard, underground mines or mines susceptible to firedamp.



TECHNICAL DATA

Temperature class	T3
Ex Protection type	Ex II 2 GD
Gases	Ex db IIC T3 Gb
Dusts	Ex tb IIIC T200°C Db IP66
Mine applications	I M2 Ex db I Mb
Ambient temperature	-60 to +85 °C (-76 to +185 °F)
Surface temperature	max. +200 °C (+392 °F)
Heating element	high performance cartridge
Heating body	aluminium profile, silver anodised
Connection	silicone cable (halogen-free) 3 x 0.75 mm ²
Connection PE	0.75 to 2.5 mm ²
Mounting	clip for 35 mm DIN rail, EN 60715 for heating body sizes 80 x 48 mm and 120 x 60 mm; screw fixing with 2 plug-on flanges for all heating body sizes, optional widthwise mounting
Fitting position	vertical airflow (connection on bottom)
Storage temperature	-60 to +85 °C (-76 to +185 °F)
Operating/Storage humidity	max. 90 % RH (non-condensing)
Protection type/Protection class	IP66 / I (earthed)
Approvals	EPS 16 ATEX 1109 X IECEx EPS 16.0048X IN METRO DNV 18.0010 X EAC TC RU C-FR.Г508.В.02639

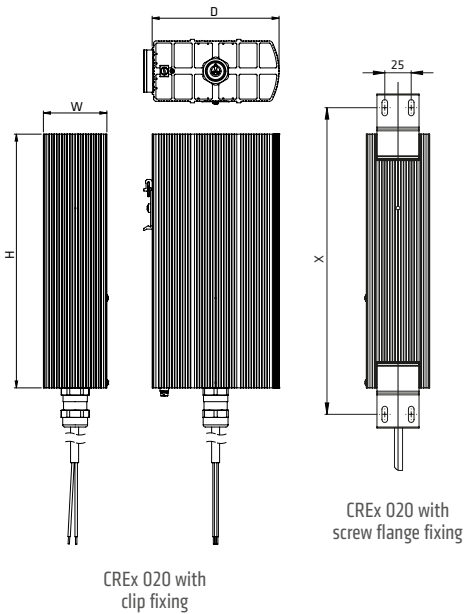

Art. No. Clip fixing		Art. No. Screw flange fixing			Operating voltage	Heating capacity	Rec. pre-fuse T (time-delayed)	Dimensions (D x W x H)	Weight approx.
Cable 1 m	Cable 2 m	Cable 1 m	Cable 2 m	Hole spacing X					
02031.0-00	02031.0-02	02031.0-10	02031.0-12	150 mm	AC 230 V	50 W	0.5 A	80 x 48 x 110 mm	0.7 kg
02031.9-00	02031.9-02	02031.9-10	02031.9-12	150 mm	AC 120 V	50 W	1.0 A	80 x 48 x 110 mm	0.7 kg
02032.0-00	02032.0-02	02032.0-10	02032.0-12	225 mm	AC 230 V	100 W	1.0 A	80 x 48 x 180 mm	1.0 kg
02032.9-00	02032.9-02	02032.9-10	02032.9-12	225 mm	AC 120 V	100 W	2.0 A	80 x 48 x 180 mm	1.0 kg
02033.0-00	02033.0-02	02033.0-10	02033.0-12	225 mm	AC 230 V	150 W	1.5 A	120 x 60 x 180 mm	1.4 kg
02033.9-00	02033.9-02	02033.9-10	02033.9-12	225 mm	AC 120 V	150 W	3.0 A	120 x 60 x 180 mm	1.4 kg
02034.0-00	02034.0-02	02034.0-10	02034.0-12	300 mm	AC 230 V	200 W	2.0 A	120 x 60 x 240 mm	1.7 kg
02034.9-00	02034.9-02	02034.9-10	02034.9-12	300 mm	AC 120 V	200 W	4.0 A	120 x 60 x 240 mm	1.7 kg
-	-	02035.0-10	02035.0-12	275 mm	AC 230 V	250 W	2.5 A	160 x 80 x 220 mm	2.3 kg
-	-	02035.9-10	02035.9-12	275 mm	AC 120 V	250 W	5.0 A	160 x 80 x 220 mm	2.3 kg

HAZARDOUS AREA HEATER

CREX 020 | 50 W to 200 W (T4)



- > For areas with explosion and firedamp hazard
- > Large convection surface
- > Clip and screw flange fixing
- > Ready-to-use with strain relief
- > Maintenance free
- > Temperature class T4

Compact convection heater of temperature class T4 (135 °C max.) for the prevention of formation of condensation, temperature fluctuations, and for protection against frost within control and switch cabinets, as well as measuring equipment located in areas with explosion hazard, underground mines or mines susceptible to firedamp.



TECHNICAL DATA

Temperature class	T4
Ex Protection type	Ex II 2 GD
Gases	Ex db IIC T4 Gb
Dusts	Ex tb IIIC T135°C Db IP66
Mine applications	I M2 Ex db I Mb
Ambient temperature	-60 to +50 °C (-76 to +122 °F)
Surface temperature	max. +135 °C (+275 °F)
Heating element	high performance cartridge
Heating body	aluminium profile, silver anodised
Connection	silicone cable (halogen-free) 3 x 0.75 mm ²
Connection PE	0.75 to 2.5 mm ²
Mounting	clip for 35 mm DIN rail, EN 60715 for heating body sizes 80 x 48 mm and 120 x 60 mm; screw fixing with 2 plug-on flanges for all heating body sizes, optional widthwise mounting
Fitting position	vertical airflow (connection on bottom)
Storage temperature	-60 to +85 °C (-76 to +185 °F)
Operating/Storage humidity	max. 90 % RH (non-condensing)
Protection type/Protection class	IP66 / I (earthed)
Approvals	EPS 16 ATEX 1109 X IECEx EPS 16.0048X IN METRO DNV 18.0010 X EAC TC RU C-FR.Г508.В.02639

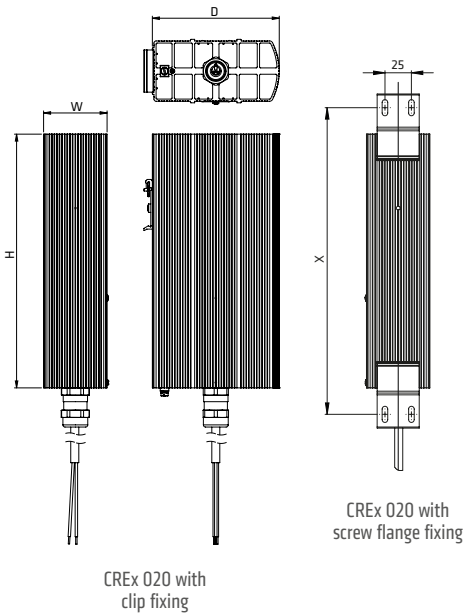

Art. No. Clip fixing		Art. No. Screw flange fixing			Operating voltage	Heating capacity	Rec. pre-fuse T (time-delayed)	Dimensions (D x W x H)	Weight approx.
Cable 1 m	Cable 2 m	Cable 1 m	Cable 2 m	Hole spacing X					
02041.0-00	02041.0-02	02041.0-10	02041.0-12	150 mm	AC 230 V	50 W	0.5 A	80 x 48 x 110 mm	0.7 kg
02041.9-00	02041.9-02	02041.9-10	02041.9-12	150 mm	AC 120 V	50 W	1.0 A	80 x 48 x 110 mm	0.7 kg
02042.0-00	02042.0-02	02042.0-10	02042.0-12	225 mm	AC 230 V	100 W	1.0 A	120 x 60 x 180 mm	1.4 kg
02042.9-00	02042.9-02	02042.9-10	02042.9-12	225 mm	AC 120 V	100 W	2.0 A	120 x 60 x 180 mm	1.4 kg
-	-	02043.0-10	02043.0-12	275 mm	AC 230 V	150 W	1.5 A	160 x 80 x 220 mm	2.3 kg
-	-	02043.9-10	02043.9-12	275 mm	AC 120 V	150 W	3.0 A	160 x 80 x 220 mm	2.3 kg
-	-	02044.0-10	02044.0-12	350 mm	AC 230 V	200 W	2.0 A	160 x 80 x 300 mm	2.8 kg
-	-	02044.9-10	02044.9-12	350 mm	AC 120 V	200 W	4.0 A	160 x 80 x 300 mm	2.8 kg

HAZARDOUS AREA HEATER

CREX 020 | 50 W, 100 W (T5)



- > For areas with explosion and firedamp hazard
- > Large convection surface
- > Clip and screw flange fixing
- > Ready-to-use with strain relief
- > Maintenance free
- > Temperature class T5

Compact convection heater of temperature class T5 (100 °C max.) for the prevention of formation of condensation, temperature fluctuations, and for protection against frost within control and switch cabinets, as well as measuring equipment located in areas with explosion hazard, underground mines or mines susceptible to firedamp.



TECHNICAL DATA

Temperature class	T5
Ex Protection type	Ex II 2 GD
Gases	Ex db IIC T5 Gb
Dusts	Ex tb IIIC T100°C Db IP66
Mine applications	I M2 Ex db I Mb
Ambient temperature	-60 to +50 °C (-76 to +122 °F)
Surface temperature	max. +100 °C (+212 °F)
Heating element	high performance cartridge
Heating body	aluminium profile, silver anodised
Connection	silicone cable (halogen-free) 3 x 0.75 mm ²
Connection PE	0.75 to 2.5 mm ²
Mounting	clip for 35 mm DIN rail, EN 60715 for heating body size 120 x 60 mm; screw fixing with 2 plug-on flanges for all heating body sizes, optional widthwise mounting
Fitting position	vertical airflow (connection on bottom)
Storage temperature	-60 to +85 °C (-76 to +185 °F)
Operating/Storage humidity	max. 90 % RH (non-condensing)
Protection type/Protection class	IP66 / I (earthed)
Approvals	EPS 16 ATEX 1109 X IECEx EPS 16.0048X IN METRO DNV 18.0010 X EAC TC RU C-FR.Г508.В.02639

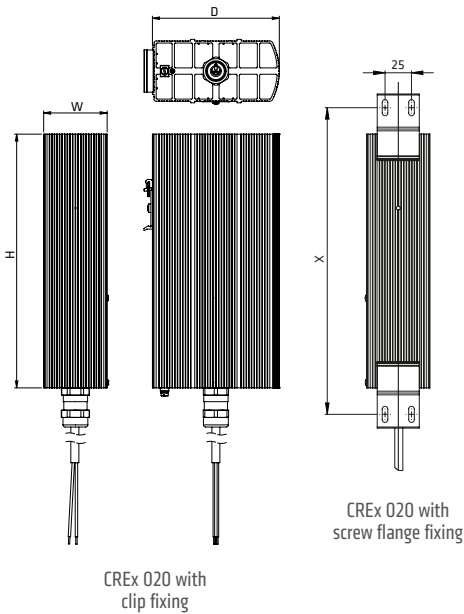

Art. No. Clip fixing		Art. No. Screw flange fixing			Operating voltage	Heating capacity	Rec. pre-fuse T (time-delayed)	Dimensions (D x W x H)	Weight approx.
Cable 1 m	Cable 2 m	Cable 1 m	Cable 2 m	Hole spacing X					
02051.0-00	02051.0-02	02051.0-10	02051.0-12	225 mm	AC 230 V	50 W	0.5 A	120 x 60 x 180 mm	1.4 kg
02051.9-00	02051.9-02	02051.9-10	02051.9-12	225 mm	AC 120 V	50 W	1.0 A	120 x 60 x 180 mm	1.4 kg
-	-	02052.0-10	02052.0-12	350 mm	AC 230 V	100 W	1.0 A	160 x 80 x 300 mm	2.8 kg
-	-	02052.9-10	02052.9-12	350 mm	AC 120 V	100 W	2.0 A	160 x 80 x 300 mm	2.8 kg

HAZARDOUS AREA THERMOSTAT

REX 011 | 15 °C, 25 °C (T6)



- > For areas with explosion and firedamp hazard
- > High switching capacity
- > Compact Design
- > Set temperature
- > Ready-to-use with strain relief
- > Temperature class T6

Compact, small mechanical thermostat offering a high response accuracy/time, small switch temperature difference, and a very long service life (switching cycles). This thermostat of temperature class T6 (85 ° max.) is utilised for the regulation of heaters within control and switch cabinets, as well as measuring equipment located in areas with explosion hazard, underground mines and mines susceptible to firedamp. The high switching performance allows for direct control of heaters.



TECHNICAL DATA

Temperature class	T6
Ex Protection type	Ex II 2 GD
Gases	Ex db IIC T6 Gb
Dusts	Ex tb IIIC T85°C Db IP66
Mine applications	I M2 Ex db I Mb
Ambient temperature	-60 to +60 °C (-76 to +140 °F)
Sensor element	thermostatic bimetal
Service life	> 100,000 cycles
Max. switching capacity	AC 250 V 10 A ¹ DC 24 V 1 A
Min. switching capacity	DC 1.5 V 5 mA
Max. inrush current	AC 16 A for 12 sec.
Connection	silicone cable (halogen-free) 3 x 1 mm ²
Connection PE	1.0 to 2.5 mm ²
Mounting	clip for 35 mm DIN rail, EN 60715 screw fixing M5, optional widthwise mounting
Casing	aluminium, silver anodised
Dimensions	95 x 45 x 30 mm
Weight	approx. 0.3 kg
Fitting position	variable
Storage temperature	-60 to +85 °C (-76 to +185 °F)
Operating/Storage humidity	max. 90 % RH (non-condensing)
Protection type/Protection class	IP66 / I (earthed)
Approvals	EPS 16 ATEX 1 118 X IECEx EPS 16.0054X IN METRO DNV 18.0011 X EAC TC RU C-FR.Г508.В.02639

¹ currents above 4 A affect the switch temperature difference

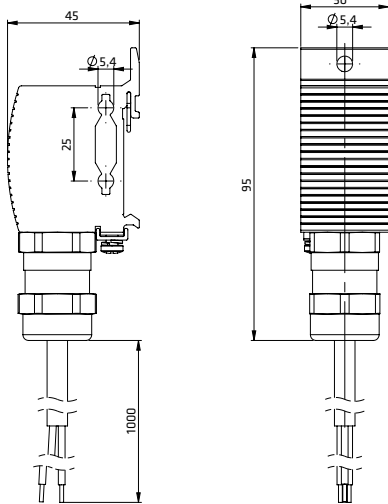

Art. No.	Cable Length	Contact type (1-pole)	Switch temperature	Switch temperature difference
01185.0-00	1 m	Contact breaker (NC)	+15 °C (±3 K tolerance)	5 K (±3 K tolerance)
01185.1-00	1 m	Contact breaker (NC)	+25 °C (±3 K tolerance)	5 K (±3 K tolerance)
01185.0-01	2 m	Contact breaker (NC)	+15 °C (±3 K tolerance)	5 K (±3 K tolerance)
01185.1-01	2 m	Contact breaker (NC)	+25 °C (±3 K tolerance)	5 K (±3 K tolerance)

LOCATIONS

THE FAST TRACK TO STEGO



STEGO is represented globally and proud to offer its customers maximum availability, personal visits and consultations. With 12 locations and more than 1500 sales partners worldwide, customer service is our top priority. Whenever you need support in matters of enclosure climatisation and thermal management – your STEGO contact is not far away.

You will find contact details of our subsidiaries below:

→ GERMANY

STEGO Elektrotechnik GmbH
 Kolpingstraße 21
 74523 Schwäbisch Hall
 Deutschland
 Phone +49 791 95058 0
 Fax +49 791 95058 45
 info@stego.de
 www.stego.de

→ SWEDEN

STEGO Norden AB
 Företagsallén 4
 184 40 Åkersberga
 Box 2019
 184 23 Åkersberga
 Sverige
 Phone +46 8 545 86160
 Fax +46 8 545 86161
 info@stegonorden.se
 www.stegonorden.se

→ USA

STEGO, Inc.
 1395 S. Marietta Pkwy
 Building 800
 Marietta, GA 30067
 USA
 Phone +1 770 984 0858
 Fax +1 770 984 0615
 info@stegousa.com
 www.stegousa.com

→ BRAZIL

STEGO do Brasil Ltda.
 Rua Bahia, 474 – Jd. Califórnia
 12062-100 Taubaté – SP
 Brasil
 Phone +55 12 3632-5070
 Fax +55 12 3632-5075
 info@stego.com.br
 www.stego.com.br

→ ITALY

STEGO Italia S.r.l.
Via Marie Curie, 27
10073 Ciriè (TO)
Italia
Phone +39 011 4593 287
Fax +39 011 4593 164
info@stego.it
www.stego.it

→ ENGLAND

STEGO UK Ltd.
Unit 12, First Quarter Business Park
Blenheim Road
Epsom
Surrey KT19 9QN
England
Phone +44 1372 747250
Fax +44 1372 729854
info@stego.co.uk
www.stego.co.uk

→ POLAND

STEGO Polska Sp. z o.o.
ul. Banacha 11
41-200 Sosnowiec
Polska
Phone +48 32 263 22 42
Fax +48 32 263 22 68
info@stego.pl
www.stego.pl

→ NETHERLANDS

STEGO Nederland B.V.
Oosterbracht 17
7821 CC Emmen
Postbus 1193
7801 BD Emmen
Nederland
Phone +31 591 633 666
Fax +31 591 632 640
info@stegonederland.nl
www.stegonederland.nl

→ FRANCE

STEGO France SAS
Port de Conflans Fin d'Oise
Le Beaupré N° 2
78700 Conflans Sainte Honorine
France
Phone +33 1 39 19 57 57
Fax +33 1 39 19 54 47
info@stego.fr
www.stego.fr

→ SPAIN

STEGOTRONIC S.A.
C/ Francia, n° 20, Nave 2
Polígono Industrial Les Comes
08700 Igualada (Barcelona)
España
Phone +34 93 806 6026
Fax +34 93 806 6057
stegotronic@stegotronic.es
www.stego.de/es

→ CZECH REPUBLIC

STEGO Czech s.r.o.
Přípotoční 1519/10b
100 00 Praha 10 – Vršovice
Česká republika
Phone +420 261 910 544
Fax +420 261 910 545
info@stego.cz
www.stego.cz

→ RUSSIA

OOO "STEGO RUS"
Kommunisticheskaya Street 10,
Bldg. 1, Office 413, 420
141011 Moscow region
Mytishchi
Russia
Phone/Fax +7 495 255 07 88
Mobile +7 926 835 67 34
info@stego.ru
www.stego.ru

→ **STEGO Elektrotechnik GmbH**
Kolpingstraße 21
74523 Schwäbisch Hall
Germany

Phone +49 791 95058 0
Fax +49 791 95058 45

info@stego.de
www.stego.de

